

TQP3M9039

500–1500 MHz Dual LNA



Applications

- Base Station Receivers
- Tower Mount Amplifiers
- Balanced Amplifiers
- FDD-LTE, TDD-LTE, WCDMA, CDMA, GSM
- General Purpose Wireless

Product Features

- 500–1500 MHz Operational bandwidth
- 0.5 dB Noise Figure (Single Channel)
- 18 dB Gain at 830 MHz
- +20.7 dBm Input IP3
- Integrated shut-down biasing feature
- Bias adjustable
- Does not require negative voltage supply
- 4x4 mm 16-pin QFN plastic package

General Description

The TQP3M9039 is a high linearity, ultra low noise figure dual device amplifier in a 4x4 mm package. At 830 MHz in a balanced configuration, the LNA provides 18 dB gain, 20.7 dBm IIP3 and 0.6 dB noise figure. The part does not require a negative supply for operation and is bias adjustable for both drain current and voltage. The device is housed in a green/RoHS-compliant industry standard QFN package.

The TQP3M9039 consists of a single monolithic GaAs E-pHEMT die and integrates bias circuitry as well as shut-down capability allowing the LNA to be useful for both FDD and TDD applications.

The TQP3M9039 is optimized for the 500–1500 MHz band, but can be used outside of the band. TriQuint offers pin-compatible dual LNAs for the 1.5–2.3 GHz band (TQP3M9040) and 2.3–2.7 GHz (TQP3M9041). The balanced amplifier is optimized for high performance receivers in wireless infrastructure and can be used for base-station transceivers or tower-mounted amplifiers.

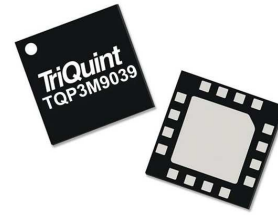

16-pin 4x4 mm QFN Package

Functional Block Diagram

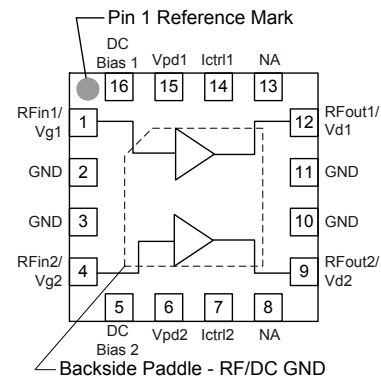

Pin Configuration

Pin No.	Symbol
1	RFIn1/Vg1
4	RFIn2/Vg2
12	RFout1/Vd1
9	RFout2/Vd2
2, 3, 10, 11	Ground
16	DC Bias 1
5	DC Bias 2
15	Vpd1
6	Vpd2
14	Ictrl1
7	Ictrl2
Backside Paddle	RF/DC GND

Ordering Information

Part No.	Description
TQP3M9039	500–1500 MHz Dual LNA
TQP3M9039-PCB	700–1000 MHz Evaluation Board

Standard T/R size = 2500 pieces on a 13" reel

TQP3M9039

500–1500 MHz Dual LNA



Absolute Maximum Ratings

Parameter	Rating
Storage Temperature	-65 to 150°C
Drain Voltage (V_d)	+7 V
Pin (CW)	+25 dBm

Operation of this device outside the parameter ranges given above may cause permanent damage.

Recommended Operating Conditions

Parameter	Min	Typ	Max	Units
V_{pd}	0		+5	V
V_g	0	+0.5	+1	V
V_d	+2		+5	V
I_d , single channel		57	TBD	mA
Operating Temp. Range	-40		+85	°C
T_{ch} (for $>10^6$ hrs MTTF)			190	°C

Electrical specifications are measured at specified test conditions. Specifications are not guaranteed over all recommended operating conditions.

Electrical Specifications

Test conditions unless otherwise noted: $V_d = +4.35V$, Temp. = +25°C, tuned balanced configuration

Parameter	Conditions	Min	Typ	Max	Units
Operational Frequency Range		500		1500	MHz
Test Frequency			830		MHz
Gain			18.1		dB
Output P1dB			+21.5		dBm
Input IP3	Pin = -13 dBm/tone, $\Delta f = 1$ MHz		+20.7		dBm
Output IP3	Pout = +5 dBm/tone, $\Delta f = 1$ MHz		+38.8		dBm
Noise Figure			0.6		dB
Noise Figure	Single Channel		0.5		dB
Drain Voltage, V_d			+4.35		V
Drain Current, I_d	Single Channel		57		mA
Power Down Control Voltage, V_{pd}	On-State	0		+0.3	V
	Off-State	+2.1		V_d	V
Thermal Resistance, θ_{jc}	Per Channel		61		°C/W

Application Circuit – TQP3M9039-PCB

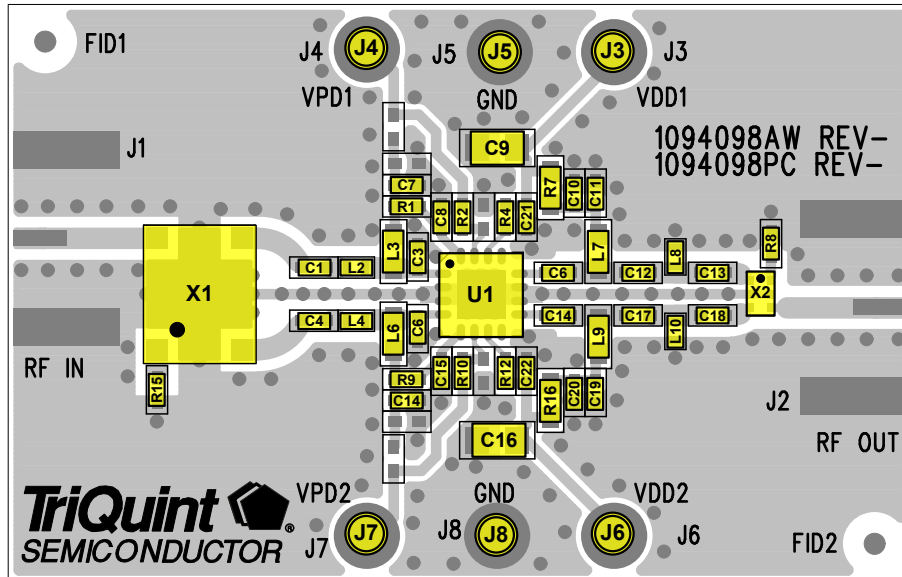

See Evaluation Board PCB Information section for PCB material and stack-up.

Bill of Material – TQP3M9039-PCB

Reference Des.	Value	Description	Manuf.	Part Number
U1	n/a	Dual LNA	TriQuint	TQP3M9039
X1	n/a	Hybrid coupler	Anaren	X3C09P1-03S
X2	n/a	Hybrid coupler	Anaren	C0810J5003AHF
R1, R9	330 Ω	RES, 0402, +/-5%, 1/10W	Various	
R8, R15	51 Ω	RES, 0402, +/-5%, 1/10W	Various	
R6, R14	10 Ω	RES, 0402, +/-5%, 1/10W	Various	
R4, R12	3K Ω	RES, 0402, +/-5%, 1/10W	Various	
R7, R16	2.2 Ω	RES, 0603, +/-5%, 1/8W	Various	
R2, R10	0 Ω	RES, 0402, +/-5%, 1/10W	Various	
C1, C4	47 pF	CAP, 0402, +/-5%, 50V	Panasonic	ECJ-0EC1H470J
C3, C6	1.2 pF	CAP, 0402, +/-0.1pF, 25V	Panasonic	ECD-G0E1R2B
C7, C14	1.8 pF	CAP, 0402, +/-0.1pF, 50V	AVX	04025U1R8BAT2A
C8, C15, C21, C22, C11, C19	100 pF	CAP, 0402, +/-5%, 50V	Panasonic	ECJ-0EC1H101J
C9, C16	0.01 uF	CAP, 0805, +/-5%, 50V, X7R	Various	
C10, C20	1000 pF	CAP, 0402, +/-10%, 50V	Various	
C12, C13, C17, C18	2.2 pF	CAP, 0402, +/-0.1pF, 50V	AVX	04025U2R2BAT2A
L2, L4	6.8 nH	IND, 0402, +/-5%	Coilcraft	0402CS-6N8XJL
L3, L6	220 nH	IND, 0603, +/-5%	Coilcraft	0603CS-R22XJL
L7, L9	47 nH	IND, 0603, +/-5%, 600mA	Coilcraft	0603CS-47NXJL
L8, L10	10 nH	IND, 0402, +/-5%	Coilcraft	0402CS-10NXJL

Notes:

1. R2 and R10 may be replaced with metal trace in target applications

TQP3M9039

500–1500 MHz Dual LNA



Application Circuit – TQP3M9039-PCB

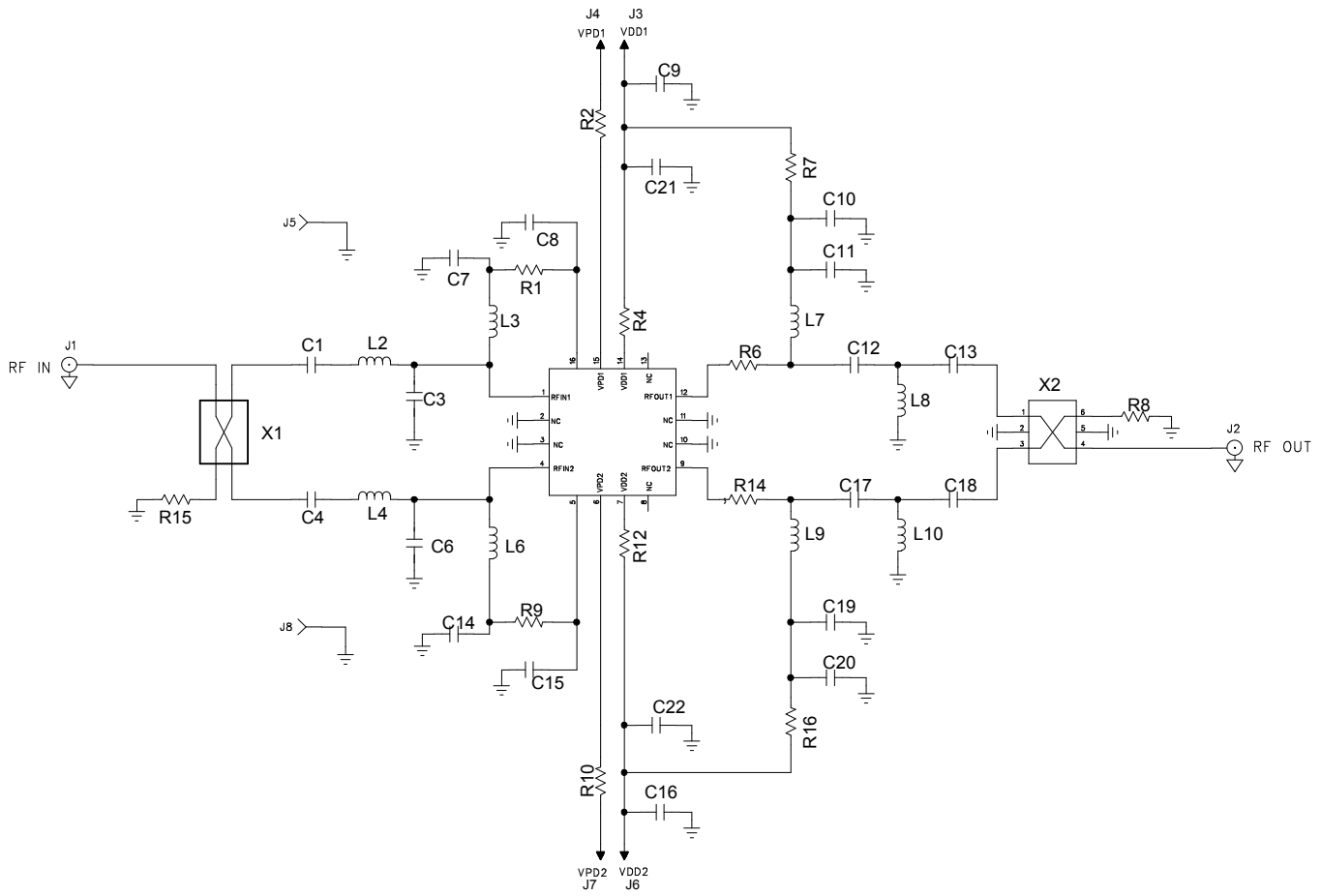

Typical Performance (Balanced Configuration)

Test conditions unless otherwise noted: $V_d = +4.35\text{ V}$, $I_d = 57\text{ mA}$, Temp. = $+25^\circ\text{C}$

Parameter	Typical Value				Units
Frequency	700	830	900	1000	MHz
Gain	17.1	18.1	17.8	16.8	dB
Noise Figure	0.65	0.6	0.62	0.7	dB
Input Return Loss	28	24	26	43	dB
Output Return Loss	32	27	27	34	dB
Output P1dB	+21.3	+21.5	+21	+20.3	dBm
IIP3 (Pin/tone = -13 dBm, $\Delta f = 1\text{ MHz}$)	+18.8	+20.7	+21	+21.9	dBm

Performance Plots (Balanced Configuration)

Test conditions unless otherwise noted: $V_d = +4.35\text{ V}$, $I_d = 57\text{ mA}$, Temp. = $+25^\circ\text{C}$

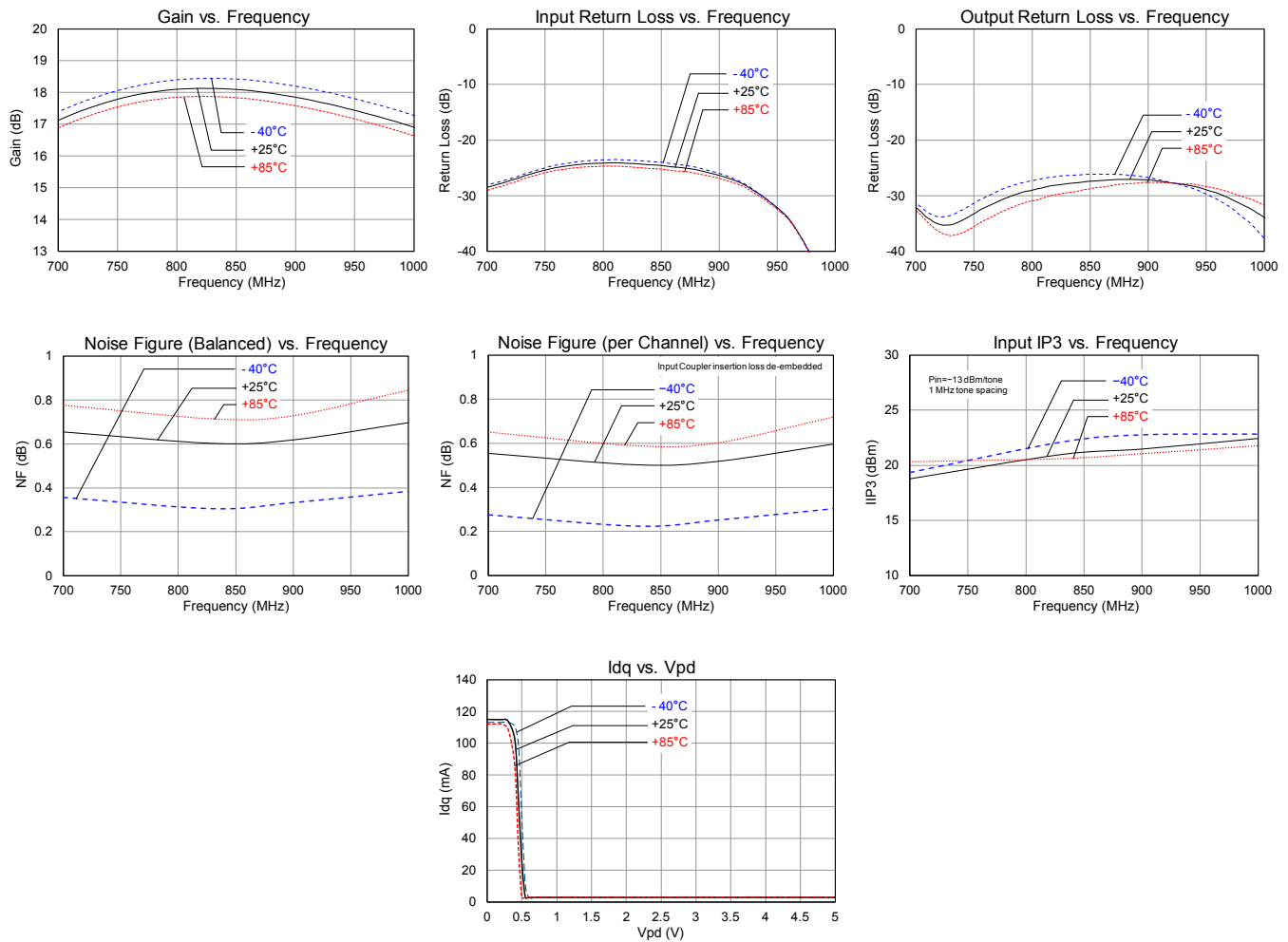

Pin Configuration and Description

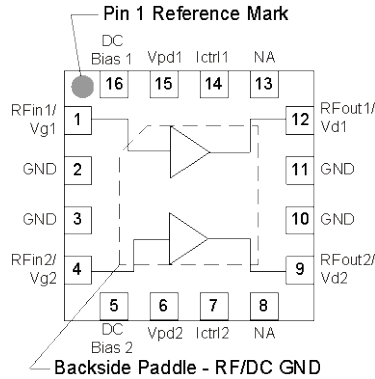

Pin No.	Symbol	Description
1	RFIn1/Vg1	RF input pin for channel 1. Gate voltage bias pin for channel 1.
2, 3, 10, 11	GND	No internal connection but should be grounded to provide PCB mounting integrity and isolation between the two RF paths.
4	RFIn2/Vg2	RF input pin for channel 2. Gate voltage bias pin for channel 2.
5	DC Bias 2	DC out bias for channel 2
6	Vpd2	Power down control voltage for channel 1
7	Ictrl2	Channel 2 drain current control
8, 13	NA	No internal connection. These pins can be grounded to provide PCB mounting integrity.
9	RFout2/Vd2	RF output pin for channel 2. Gate voltage bias pin for channel 2.
12	RFout1/Vd1	RF output pin for channel 1. Drain voltage bias pin for channel 1.
14	Ictrl1	Channel 1 drain current control
15	Vpd1	Power down control voltage for channel 1
16	DC Bias 1	DC out bias for channel 1
Backside Paddle	RF/DC GND	RF/DC Ground. Follow recommended via pattern and ensure good solder attach for best thermal and electrical performance.

Evaluation Board PCB Information

TriQuint PCB 1094098 Material and Stack-up

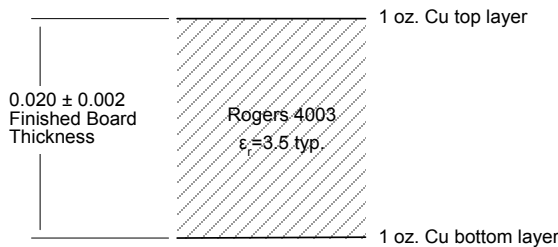

50 ohm line dimensions: width = .040", spacing = .020"

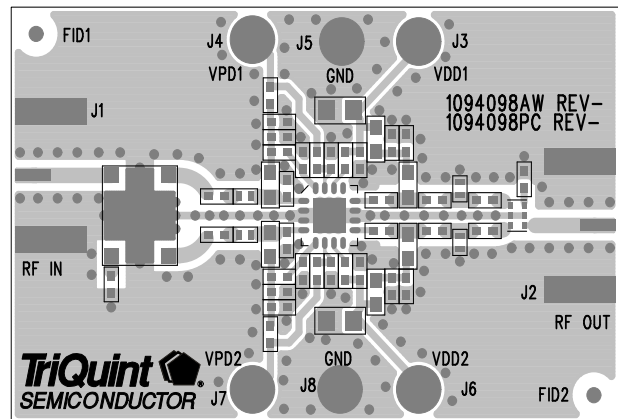

Mechanical Information

Package Marking and Dimensions

Marking: Part number – 3M9039
 Year, week - YYWW
 Assembly code - AaXXXX

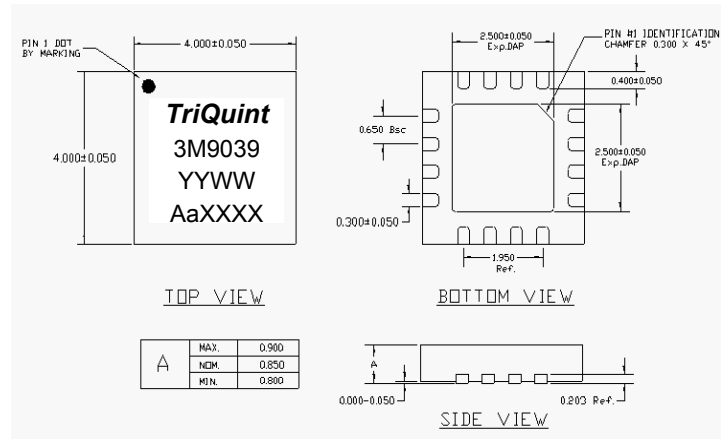

Notes:

1. All dimensions are in millimeters. Angles are in degrees.
2. Except where noted, this part outline conforms to JEDEC standard MO-220, Issue E (Variation VGGC) for thermally enhanced plastic very thin fine pitch quad flat no lead package (QFN).
3. Dimension and tolerance formats conform to ASME Y14.4M-1994.
4. The terminal #1 identifier and terminal numbering conform to JESD 95-1 SPP-012

PCB Mounting Pattern

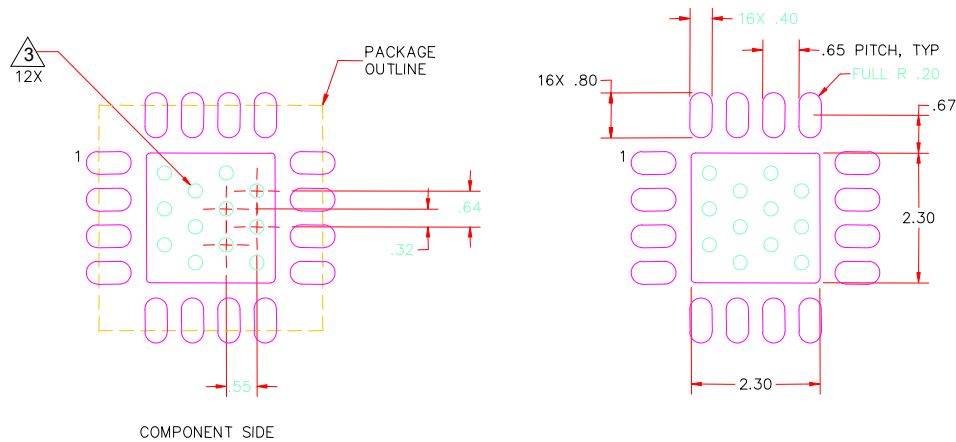

Notes:

1. All dimensions are in millimeters. Angles are in degrees.
2. Use 1 oz. copper minimum for top and bottom layer metal.
3. We recommend a 0.35mm (#80/.0135") diameter bit for drilling via holes and a final plated thru diameter of 0.25 mm (0.10").
4. Ensure good package backside paddle solder attach for reliable operation and best electrical performance.

Product Compliance Information

ESD Sensitivity Ratings



Caution! ESD-Sensitive Device

ESD Rating: Class 0
Value: ≥ 100 V and < 250 V
Test: Human Body Model (HBM)
Standard: JEDEC Standard JESD22-A114

ESD Rating: Class III
Value: ≥ 500 V and < 1000 V
Test: Charged Device Model (CDM)
Standard: JEDEC Standard JESD22-C101

MSL Rating

MSL Rating: Level 1
Test: 260°C convection reflow
Standard: JEDEC Standard IPC/JEDEC J-STD-020

Solderability

Compatible with both lead-free (260°C max. reflow temperature) and tin/lead (245°C max. reflow temperature) soldering processes.

Package contact plating: NiPdAu

RoHs Compliance

This part is compliant with EU 2002/95/EC RoHS directive (Restrictions on the Use of Certain Hazardous Substances in Electrical and Electronic Equipment).

This product also has the following attributes:

- Lead Free
- Halogen Free (Chlorine, Bromine)
- Antimony Free
- TBBP-A (C₁₅H₁₂Br₄O₂) Free
- PFOS Free
- SVHC Free

Contact Information

For the latest specifications, additional product information, worldwide sales and distribution locations, and information about TriQuint:

Web: www.triquint.com
Email: info-sales@tqs.com

Tel: +1.503.615.9000
Fax: +1.503.615.8902

For technical questions and application information:

Email: sjcappliations.engineering@tqs.com

Important Notice

The information contained herein is believed to be reliable. TriQuint makes no warranties regarding the information contained herein. TriQuint assumes no responsibility or liability whatsoever for any of the information contained herein. TriQuint assumes no responsibility or liability whatsoever for the use of the information contained herein. The information contained herein is provided "AS IS, WHERE IS" and with all faults, and the entire risk associated with such information is entirely with the user. All information contained herein is subject to change without notice. Customers should obtain and verify the latest relevant information before placing orders for TriQuint products. The information contained herein or any use of such information does not grant, explicitly or implicitly, to any party any patent rights, licenses, or any other intellectual property rights, whether with regard to such information itself or anything described by such information.

TriQuint products are not warranted or authorized for use as critical components in medical, life-saving, or life-sustaining applications, or other applications where a failure would reasonably be expected to cause severe personal injury or death.