

TQP7M9103

1W High Linearity Amplifier



Applications

- Repeaters
- BTS Transceivers
- BTS High Power Amplifiers
- CDMA / WCDMA / LTE
- General Purpose Wireless



3-pin SOT-89 Package

Product Features

- 400-4000 MHz
- +29.5 dBm P1dB
- +45 dBm Output IP3
- 16.5 dB Gain @ 2140 MHz
- +5V Single Supply, 235 mA Current
- Internal RF overdrive protection
- Internal DC overvoltage protection
- On chip ESD protection
- Capable of handling 10:1 VSWR @ 5Vcc, 2.14 GHz, 29.5 dBm CW Pout or 20 dBm WCDMA Pout
- SOT-89 Package

Functional Block Diagram

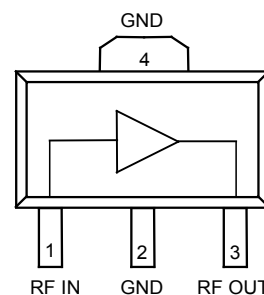

General Description

The TQP7M9103 is a high linearity driver amplifier in industry standard, RoHS compliant, SOT-89 surface mount package. This InGaP/GaAs HBT delivers high performance across a broad range of frequencies while achieving +45 dBm OIP3 and +29.5 dBm P1dB while only consuming 235 mA quiescent current. All devices are 100% RF and DC tested.

The TQP7M9103 incorporates on-chip features that differentiate it from other products in the market. The amplifier integrates an on-chip DC over-voltage and RF over-drive protection. This protects the amplifier from electrical DC voltage surges and high input RF input power levels that may occur in a system.

The TQP7M9103 is targeted for use as a driver amplifier in wireless infrastructure where high linearity, medium power, and high efficiency are required. The device an excellent candidate for transceiver line cards and high power amplifiers in current and next generation multi-carrier 3G / 4G base stations.

Pin Configuration

Pin #	Symbol
1	RF Input
3	RF Output / Vcc
2, 4	Ground

Ordering Information

Part No.	Description
TQP7M9103	1 W High Linearity Amplifier
TQP7M9103-PCB900	TQP7M9103 920-960MHz EVB
TQP7M9103-PCB2140	TQP7M9103 2.11-2.17GHz EVB

Standard T/R size = 1000 pieces on a 7" reel.

Specifications

Absolute Maximum Ratings

Parameter	Rating
Storage Temperature	-65 to +150 °C
Device Voltage, V_{cc}	+8 V
Maximum Input Power, CW	+30 dBm

Operation of this device outside the parameter ranges given above may cause permanent damage.

Recommended Operating Conditions

Parameter	Min	Typ	Max	Units
V_{cc}		+5	+5.25	V
T_{case}	-40		+85	°C
T_j (for >10 ⁶ hours MTF)			+170	°C

Electrical specifications are measured at specified test conditions. Specifications are not guaranteed over all recommended operating conditions.

Electrical Specifications

Test conditions unless otherwise noted: +25°C, +5V V_{supply} , 50 Ω system, tuned application circuit

Parameter	Conditions	Min	Typical	Max	Units
Operational Frequency Range		400		4000	MHz
Test Frequency			2140		MHz
Gain		14.7	16.6	17.7	dB
Input Return Loss			12.0		dB
Output Return Loss			15.0		dB
Output P1dB		+28.5	+29.5		dBm
Output IP3	See Note 1.	+42.5	+45		dBm
WCDMA Pout @ -50 dBc ACLR	See Note 2.		+20		dBm
Noise Figure			4.4		dB
V_{cc}			+5		V
Quiescent Current, I_{cq}		210	235	260	mA
Thermal Resistance (jnc to case) θ_{jc}				35.6	°C/W

Notes

- OIP3 measured with two tones at an output power of +15 dBm / tone separated by 1 MHz. The suppression on the largest IM3 product is used to calculate the OIP3 using 2:1 rule.
- ACLR Test set-up: 3GPP WCDMA, TM1+64 DPCH, +5 MHz offset, PAR = 10.2 dB at 0.01% Prob.

Device Characterization Data

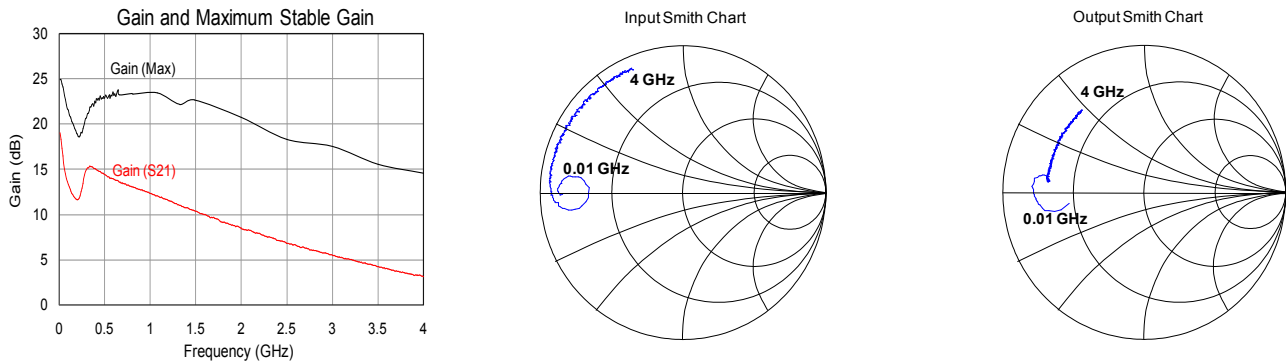

Note: The gain for the unmatched device in 50 ohm system is shown as the trace in red color, [gain (S21)]. For a tuned circuit for a particular frequency, it is expected that actual gain will be higher, up to the maximum stable gain. The maximum stable gain is shown in the black [Gain (MAX)]. The impedance plots are shown from 0.01 – 4 GHz.

S-Parameter Data

$V_{cc} = +5\text{ V}$, $I_{cq} = 235\text{ mA}$, $T = +25^{\circ}\text{C}$, unmatched 50 ohm system, calibrated to device leads

Freq (MHz)	S11 (dB)	S11 (ang)	S21 (dB)	S21 (ang)	S12 (dB)	S12 (ang)	S22 (dB)	S22 (ang)
50	-1.05	179.35	15.75	154.01	-35.54	-2.51	-2.94	-171.04
100	-1.15	176.19	13.33	155.93	-35.54	-9.63	-2.28	-176.20
200	-2.07	171.50	11.63	168.26	-37.45	-27.07	-2.00	176.45
400	-1.01	-176.54	15.01	153.46	-36.02	22.73	-3.38	172.64
600	-0.61	173.92	13.87	137.55	-35.08	6.61	-3.21	171.33
800	-0.59	169.36	13.05	125.26	-34.89	0.27	-3.18	168.76
1000	-0.62	164.62	12.35	114.05	-34.56	-4.24	-3.13	166.33
1200	-0.62	160.93	11.51	103.77	-34.60	-7.64	-3.21	164.22
1400	-0.67	156.67	10.73	94.67	-34.79	-12.27	-3.18	162.12
1600	-0.64	153.26	10.00	86.25	-34.75	-15.00	-3.21	159.50
1800	-0.75	149.43	9.12	78.19	-34.75	-17.78	-3.25	156.37
2000	-0.64	145.77	8.50	70.63	-34.81	-20.08	-3.09	154.32
2200	-0.62	142.62	7.90	63.72	-34.51	-23.77	-3.24	151.96
2400	-0.77	139.07	7.16	57.32	-34.72	-26.63	-3.10	148.69
2600	-0.66	135.41	6.58	51.13	-34.60	-29.04	-3.07	147.12
2800	-0.73	132.81	6.04	45.43	-34.65	-33.24	-3.16	144.43
3000	-0.69	128.99	5.51	39.41	-34.51	-33.49	-3.09	141.32
3200	-0.74	125.72	5.01	33.18	-34.65	-34.26	-3.12	138.96
3400	-0.74	122.13	4.52	27.44	-34.60	-37.56	-3.09	136.12
3600	-0.72	119.18	4.02	22.42	-34.56	-43.68	-3.13	133.54
3800	-0.77	116.00	3.52	16.74	-34.37	-44.96	-3.04	130.91
4000	-0.80	113.01	3.15	11.74	-34.33	-46.26	-2.96	128.69

Reference Design 869-894 MHz

Typical Performance at +25 C	(MHz)	869	880	894
Gain	dB	20.8	20.8	20.8
Input Return Loss	dB	-17.5	-18.7	-17.2
Output Return Loss	dB	-14.3	-14.4	-14.5
Output P1dB	dBm	+29.2	+29.3	+29.4
Output IP3 (+19 dBm/tone, Δf = 1 MHz)	dBm	+43.6	+42.9	+42.3
WCDMA Channel power (at -50 dBc ACLR)	dB	19.7	19.7	19.7
Supply Voltage, Vcc	V	+5		
Quiescent Collector Current, Icq	mA	235		

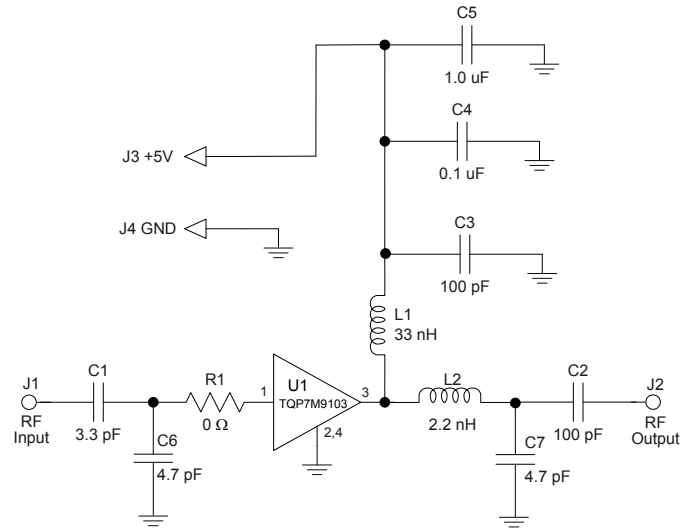
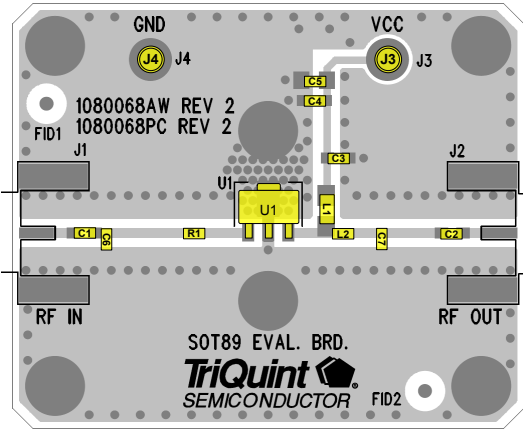

Notes:

1. See PC Board Layout, page 11 for more information.
2. The recommended component values are dependent upon the frequency of operation.
3. All components are of 0603 size unless stated on the schematic.
4. Critical component placement locations:
 - Distance from U1 Pin 1 Pad (left edge) to R1 (right edge): 128 mils (5.7° at 880 MHz)
 - Distance from R1 (left edge) to C6 (right edge): 205 mils (9.1° at 880 MHz)
 - Distance from C6 (left edge) to C1 (right edge): 10 mils (0.5° at 880 MHz)
 - Distance from U1 Pin 3 Pad (right edge) to L2 (left edge): 130 mils (5.8° at 880 MHz)
 - Distance from L2 (right edge) to C7 (left edge): 60 mils (2.7° at 880 MHz)

RF Performance Plots 869-894 MHz

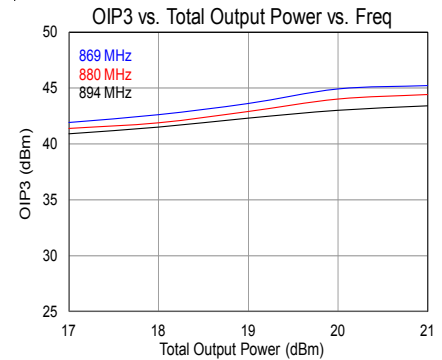
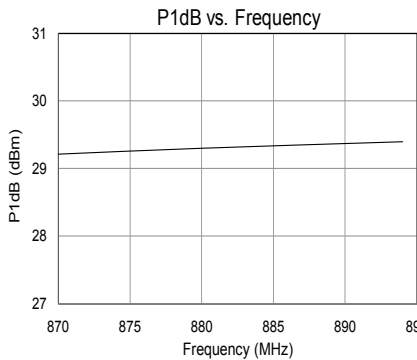
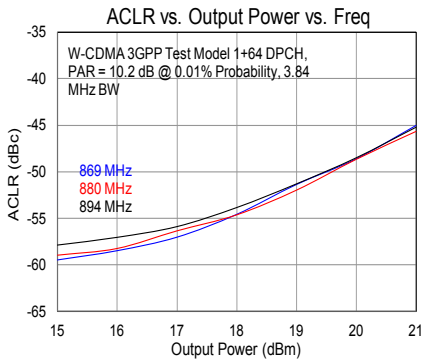
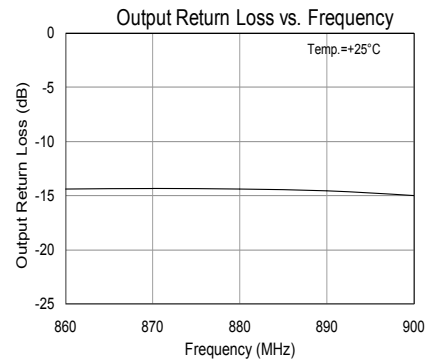
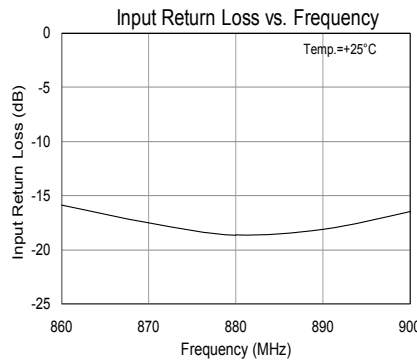
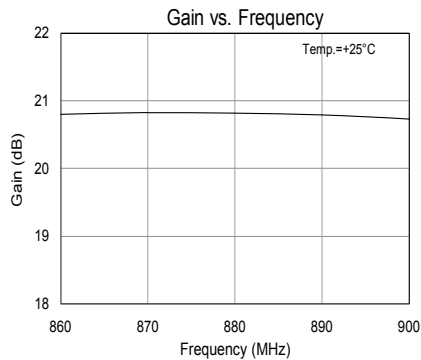

TQP7M9103

1W High Linearity Amplifier



Application Circuit 920-960 MHz (TQP7M9103-PCB900)

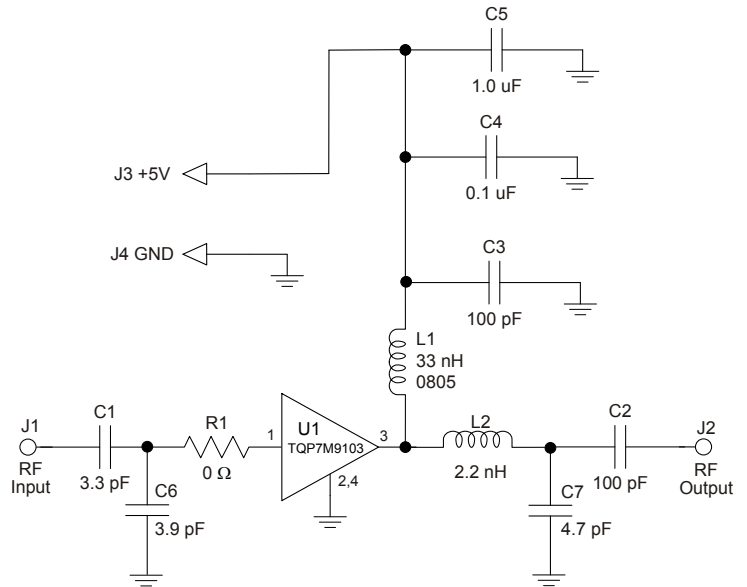
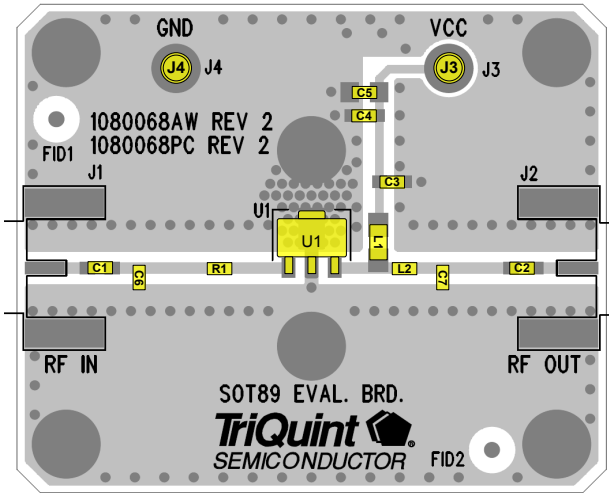

Notes:

1. See PC Board Layout, page 11 for more information.
2. Components shown on the silkscreen but not on the schematic are not used.
3. The recommended component values are dependent upon the frequency of operation.
4. All components are of 0603 size unless stated on the schematic.
5. Critical component placement locations:
 - Distance from U1 Pin 1 Pad (left edge) to R1 (right edge): 125 Mils (5.8° at 920 MHz)
 - Distance from R1 (left edge) to C6 (right edge): 169 Mils (7.9° at 920 MHz)
 - Distance from C6 (left edge) to C1 (right edge): 51 Mils (2.4° at 920 MHz)
 - Distance from U1 Pin 3 Pad (right edge) to L2 (left edge): 120 Mils (5.6° at 920 MHz)
 - Distance from L2 (right edge) to C7 (left edge): 62 Mils (2.9° at 920 MHz)

Bill of Material

Ref Des	Value	Description	Manuf.	Part Number
n/a	n/a	Printed Circuit Board	TriQuint	1080068
U1	n/a	TQP7M9103 Amplifier, SOT-89 pkg.	TriQuint	1077953
C1	3.3 pF	Cap., Chip, 0603, +/-0.1pF, 50V, Accu-P	AVX	06035J3R3ABSTR
C2, C3	100 pF	Cap., Chip, 0603, 5%, 50V, NPO/COG	various	
C4	0.1 uF	Cap., Chip, 0603, 10%, 16V, X7R	various	
C5	1.0 uF	Cap., Chip, 0603, 10%, 10V, X5R	various	
C6	3.9 pF	Cap., Chip, 0603, +/-0.05pF, 50V, Accu-P	AVX	06035J3R9ABSTR
C7	4.7 pF	Cap., Chip, 0603, +/-0.05pF, 50V, Accu-P	AVX	06035J4R7ABSTR
L1	33 nH	Inductor, 0805, 5%, Coilcraft CS Series	Coilcraft	0805CS-330XJLB
L2	2.2 nH	Inductor, 0603, +/-0.3 nH	Toko	LL1608-FSL2N2S
R1	0 Ω	Resistor, Chip, 0603, 5%, 1/16W	various	

Typical Performance 920-960 MHz (TQP7M9103-PCB900)

Frequency	MHz	920	940	960
Gain	dB	20.6	20.7	20.8
Input Return Loss	dB	-10.0	-10.8	-10.8
Output Return Loss	dB	-19.4	-20.4	-22.5
Output P1dB	dBm	+29.5	+29.4	+29.5
Output IP3 (+19 dBm/tone, $\Delta f = 1$ MHz)	dBm	+46.7	+45.4	+44.0
WCDMA Channel power (at -50 dBc ACLR) [1]	dBm	+20	+20	+20
Noise Figure	dB	5.8	5.8	5.8
Supply Voltage, Vcc	V	+5		
Quiescent Collector Current, Icq	mA	235		

Notes:

1. ACLR Test set-up: 3GPP WCDMA, TM1+64 DPCH, +5 MHz offset, PAR = 10.2 dB at 0.01% Prob.

RF Performance Plots 920-960 MHz (TQP7M9103-PCB900)

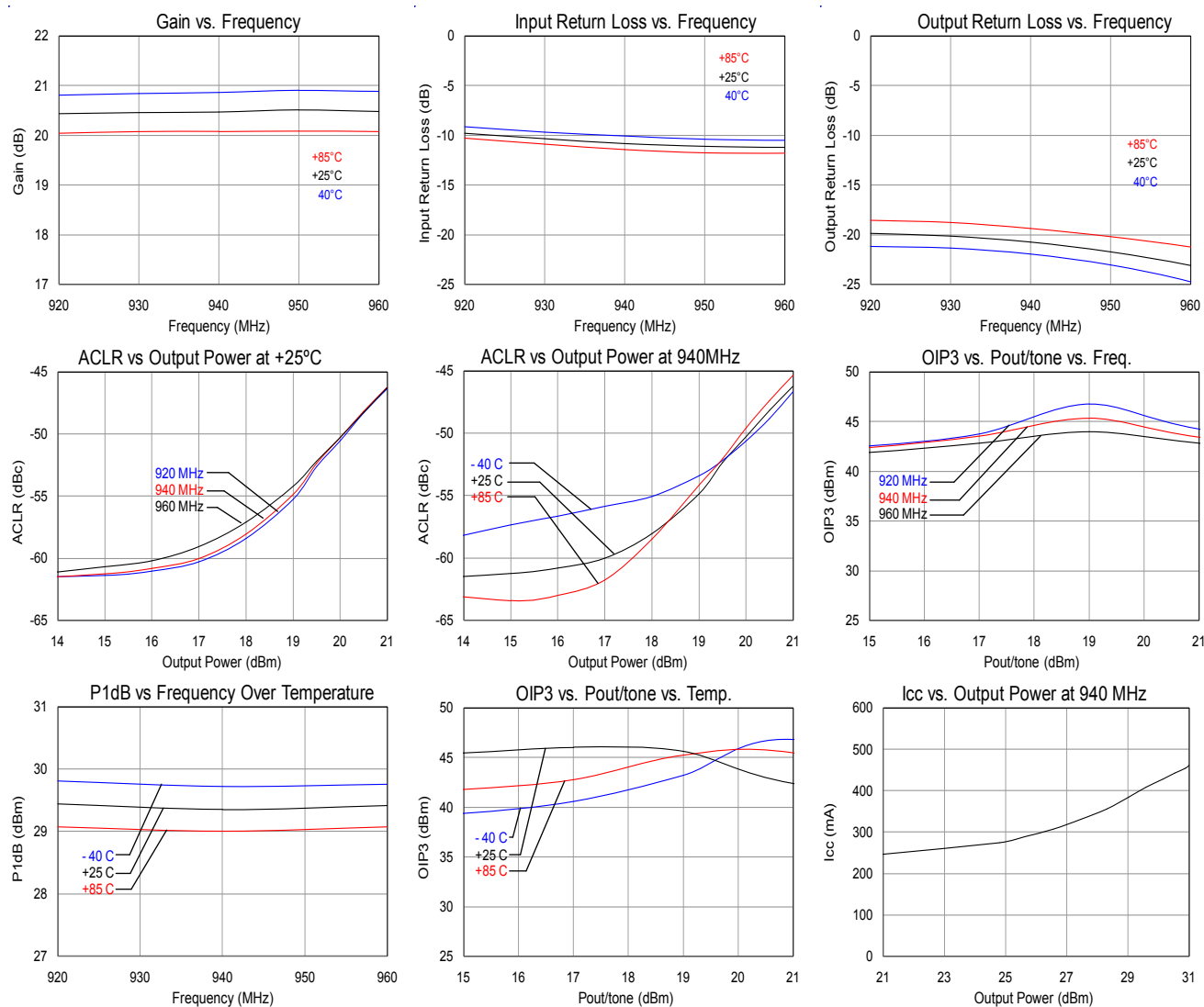

TQP7M9103

1W High Linearity Amplifier



Reference Design 1805-1880 MHz

Typical Performance at +25 C	(MHz)	1805	1850	1880
Gain	dB	17.7	17.7	17.7
Input Return Loss	dB	-11.6	-12.3	-12.1
Output Return Loss	dB	-16.1	-16.3	-16.6
Output P1dB	dBm	+29.5	+29.6	+29.5
Output IP3 (+16 dBm/tone, Δf = 1 MHz)	dBm	+44.1	+43.8	+43.2
WCDMA Channel power (at -50 dBc ACLR)	dB	+20.0	+20.2	+20.2
Supply Voltage, Vcc	V	+5		
Quiescent Collector Current, Icq	mA	235		

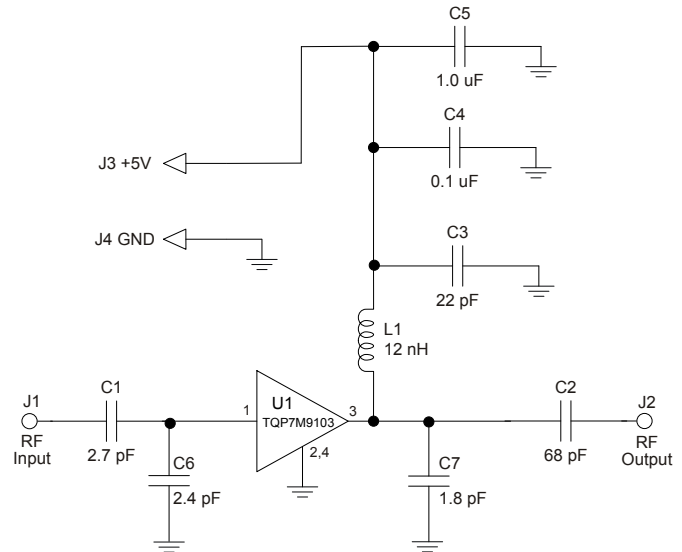
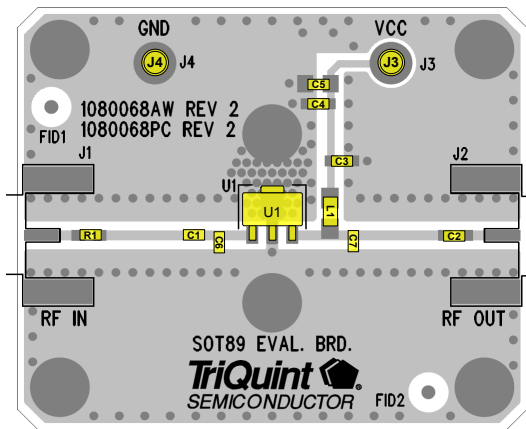

Notes:

1. See PC Board Layout, page 11 for more information.
2. All components are of 0603 size unless otherwise stated.
3. Component (R1) on PCB board is a 0 Ohm jumper and can be replaced by a copper trace.
4. Critical component placement locations:
 Distance from U1 Pin 1 Pad (left edge) to C6 (right edge): 45 mils (4.2° at 1850 MHz)
 Distance from C6 (left edge) to C1 (right edge): 20 mils (1.9° at 1850 MHz)
 Distance from U1 Pin 3 Pad (right edge) to C7 (left edge): 185 mils (17.3° at 1850 MHz)

RF Performance Plots 1805-1880 MHz

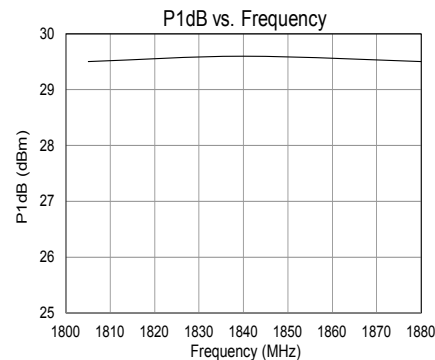
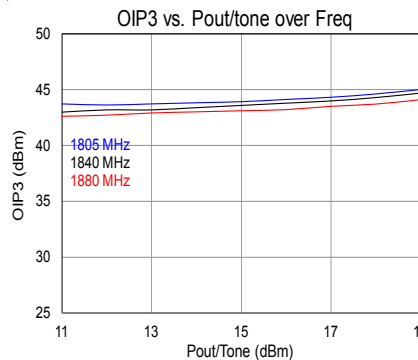
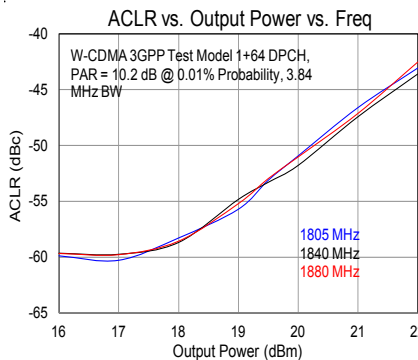
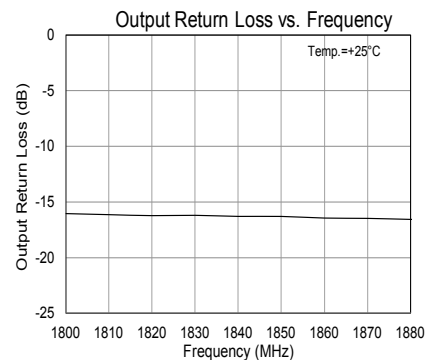
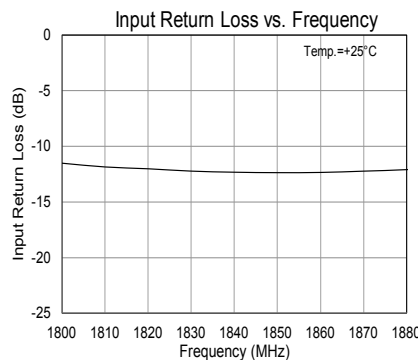
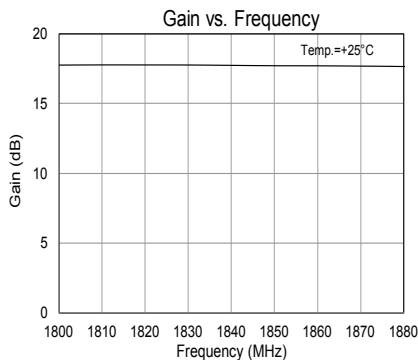

TQP7M9103

1W High Linearity Amplifier



Reference Design 1930-1960 MHz

Typical Performance at +25 C	(MHz)	1930	1960	1990
Gain	dB	17.0	17.0	16.9
Input Return Loss	dB	-15.2	-17.8	-18.3
Output Return Loss	dB	-13.0	-12.9	-12.8
Output P1dB	dBm	+29.3	+29.3	+29.3
Output IP3 (+16 dBm/tone, Δf = 1 MHz)	dBm	+44.0	+45.2	+44.2
WCDMA Channel power (at -50 dBc ACLR) [1]	dB	+20.0	+20.0	+20.0
Supply Voltage, Vcc	V		+5	
Quiescent Collector Current, Icq	mA		235	

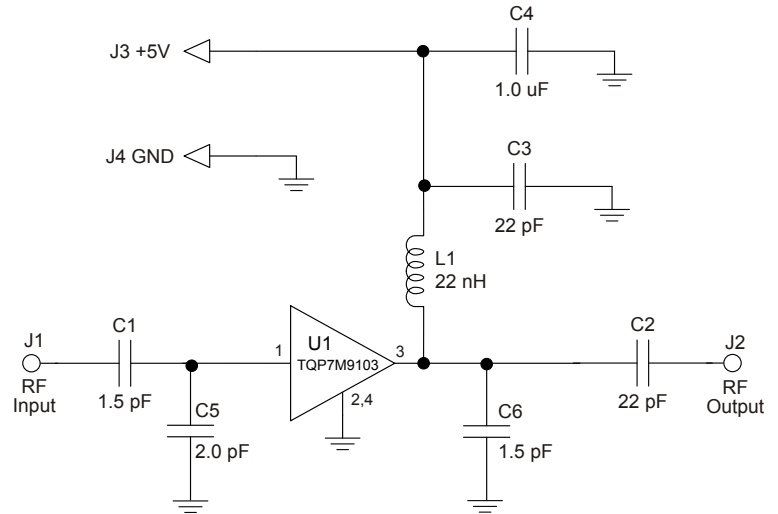
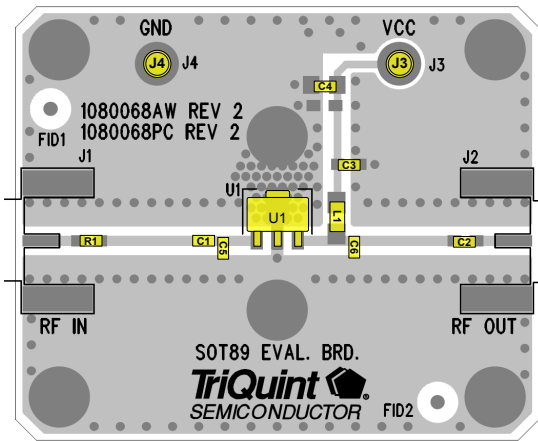

Notes:

1. See PC Board Layout, page 11 for more information.
2. The recommended component values are dependent upon the frequency of operation.
3. Component (R1) on PCB board is a 0 Ohm jumper and can be replaced by a copper trace.
4. All components are of 0603 size unless stated on the schematic.
5. Critical component placement locations:
 Distance from U1 Pin 1 Pad (left edge) to C5 (right edge): 55 mils (5.5° at 1960 MHz)
 Distance from C5 (left edge) to C1 (right edge): 10 mils (1.0° at 1960 MHz)
 Distance from U1 Pin 3 Pad (right edge) to C6 (left edge): 125 mils (12.4° at 1960 MHz)

RF Performance Plots 1930-1990 MHz

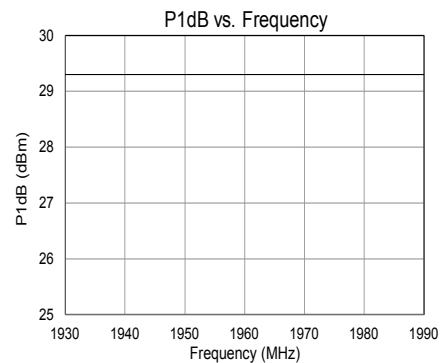
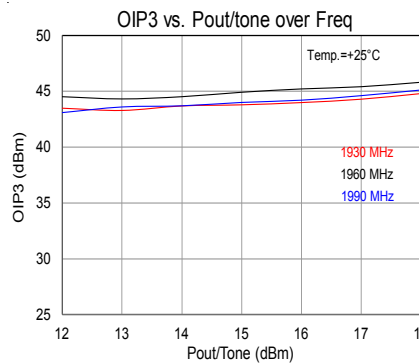
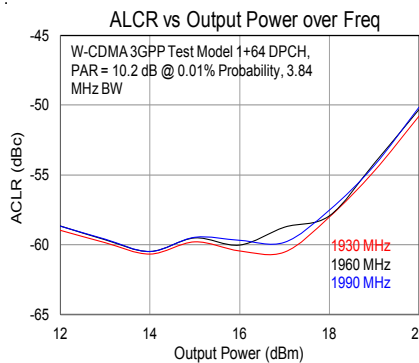
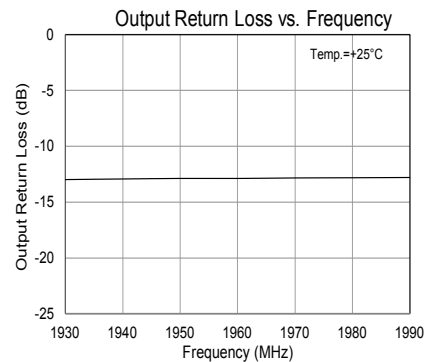
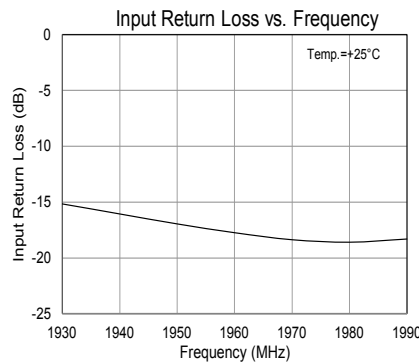
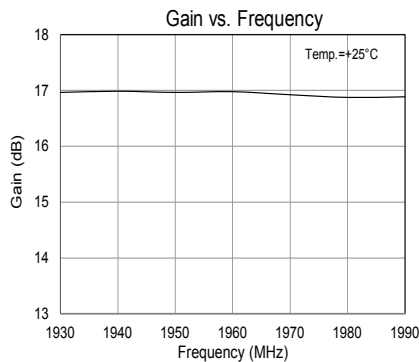

TQP7M9103

1W High Linearity Amplifier



Application Circuit 2110-2170 MHz (TQP7M9103-PCB2140)

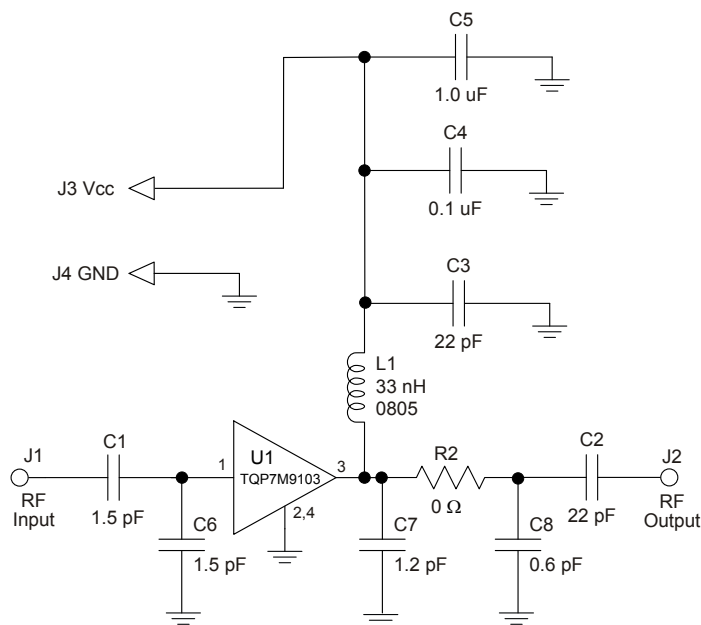
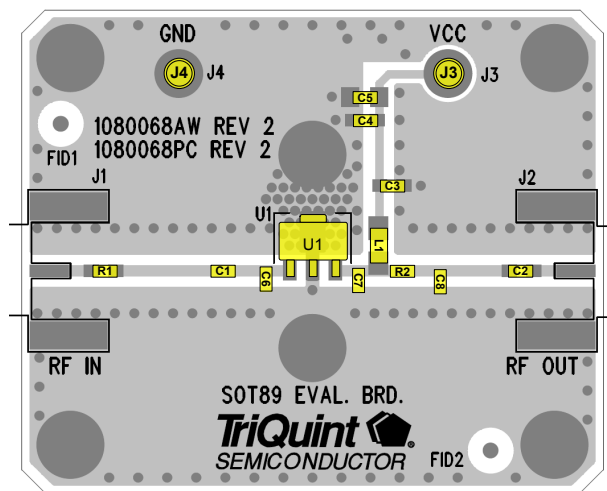

Notes:

1. See PC Board Layout, page 11 for more information.
2. Components shown on the silkscreen but not on the schematic are not used.
3. Component (R1) is a 0 Ω resistor; resistors may be replaced with copper trace in the target application layout.
4. The recommended component values are dependent upon the frequency of operation.
5. All components are of 0603 size unless stated on the schematic.
6. Critical component placement locations:
 - Distance from U1 Pin 1 Pad (left edge) to C6 (right edge): 28 Mils (3.0° at 2140 MHz)
 - Distance from C6 (left edge) to C1 (right edge): 65 Mils (7.0° at 2140 MHz)
 - Distance from U1 Pin 3 Pad (right edge) to C7 (left edge): 31 Mils (3.4° at 2140 MHz)
 - Distance from C7 (right edge) to R2 (left edge): 60 Mils (6.5° at 2140 MHz)
 - Distance from R2 (right edge) to C8 (left edge): 62 Mils (6.7° at 2140 MHz)

Bill of Material

Ref Des	Value	Description	Manuf.	Part Number
n/a	n/a	Printed Circuit Board	TriQuint	1080068
U1	n/a	TQP7M9103 Amplifier, SOT-89 pkg.	TriQuint	TQP7M9103
C1, C6	1.5 pF	Cap., Chip, 0603, +/-0.05pF, 50V, Accu-P	AVX	06032U1R5BAT2A
C2, C3	22 pF	Cap., Chip, 0603, 5%, 50V, NPO/COG	various	
C4	0.1 uF	Cap., Chip, 0603, 10%, 16V, X7R	various	
C5	1.0 uF	Cap., Chip, 0603, 10%, 10V, X5R	various	
C7	1.2 pF	Cap., Chip, 0603, +/-0.05pF, 50V, Accu-P	AVX	06035J1R2ABSTR
C8	0.6 pF	Cap., Chip, 0603, +/-0.05pF, 50V, Accu-P	AVX	06035J0R6ABSTR
R1, R2	0 Ω	Resistor, Chip, 0603, 5%, 1/16W	various	
L1	33 nH	Inductor, 0805, 5%, Coilcraft CS Series	Coilcraft	0805CS-330XJLB

Typical Performance 2110-2170 MHz (TQP7M9103-PCB2140)

Frequency	MHz	2110	2140	2170
Gain	dB	16.7	16.6	16.6
Input Return Loss	dB	-11.7	-12.0	-11.7
Output Return Loss	dB	-16.5	-16.0	-15.2
Output P1dB	dBm	+29.5	+29.5	+29.6
Output IP3 (+15 dBm/tone, $\Delta f = 1$ MHz)	dBm	+45.0	+45.0	+45.0
WCDMA Channel power (at -50 dBc ACLR) [1]	dBm	+20	+20	+20
Noise Figure	dB	4.4	4.4	4.6
Supply Voltage, Vcc	V	+5		
Quiescent Collector Current, Icq	mA	235		

Notes:

1. ACLR Test set-up: 3GPP WCDMA, TM1+64 DPCH, +5 MHz offset, PAR = 10.2 dB at 0.01% Prob.

RF Performance Plots 2110-2170 MHz (TQP7M9103-PCB2140)

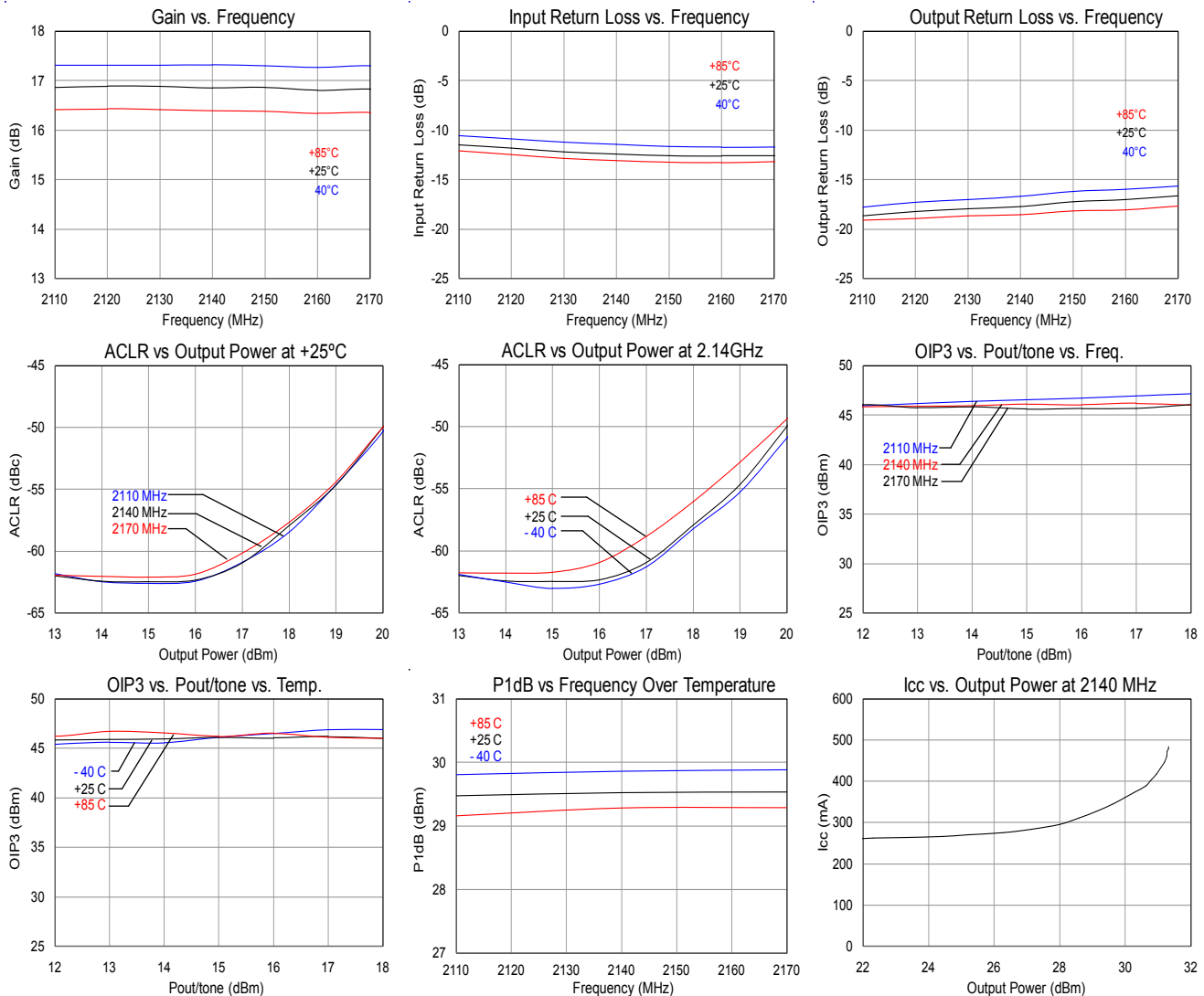

TQP7M9103

1W High Linearity Amplifier



Reference Design 2300-2400 MHz

Typical Performance at +25 C	(MHz)	2300	2350	2400
Gain	dB	16.1	16.1	15.9
Input Return Loss	dB	-13.7	-15.7	-14.0
Output Return Loss	dB	-15.4	-14.8	-14.0
Output P1dB	dBm	+29.2	+29.2	+29.3
Output IP3 (+15 dBm/tone, $\Delta f = 1$ MHz)	dBm	+45.6	+44.2	+45.2
WCDMA Channel power (at -50 dBc ACLR) [1]	dB	+20.0	+19.9	+19.9
Supply Voltage, Vcc	V	+5		
Quiescent Collector Current, Icq	mA	235		

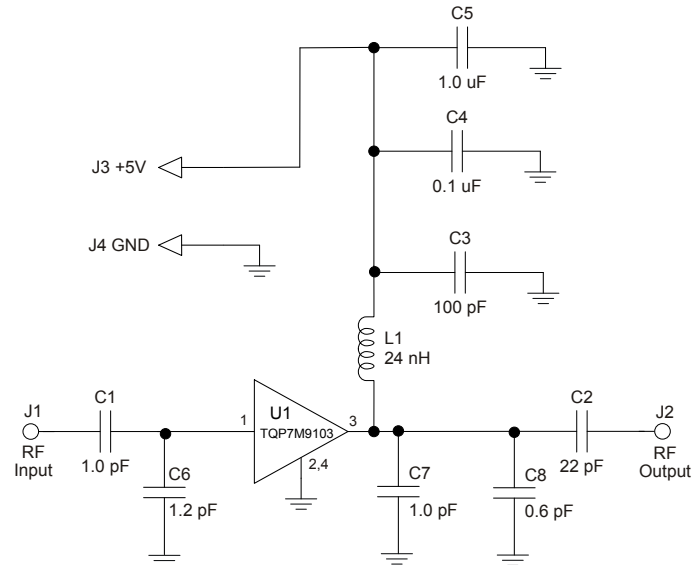
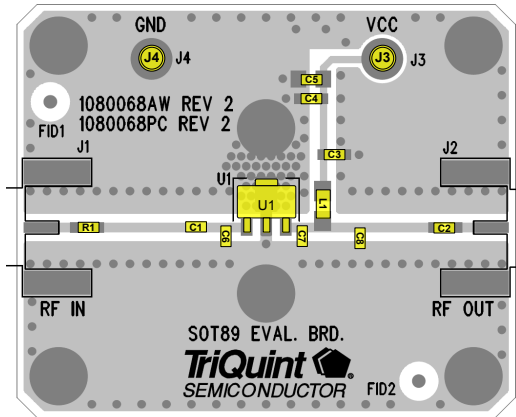

Notes:

1. See PC Board Layout, page 11 for more information.
2. The recommended component values are dependent upon the frequency of operation.
3. Component (R1) on PCB board is a 0 Ohm jumper and can be replaced by a copper trace.
4. All components are of 0603 size unless stated on the schematic.
5. Critical component placement locations:
 Distance from U1 Pin 1 Pad (left edge) to C6 (right edge): 30 mils (3.6° at 2350 MHz)
 Distance from C6 (left edge) to C1 (right edge): 75 mils (8.9° at 2350 MHz)
 Distance from U1 Pin 3 Pad (right edge) to C7 (left edge): 30 mils (3.6° at 2350 MHz)
 Distance from C7 (right edge) to C8 (left edge): 147 mils (17.5° at 2350 MHz)

RF Performance Plots 2300-2400 MHz

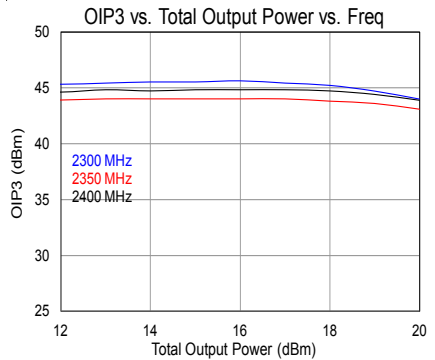
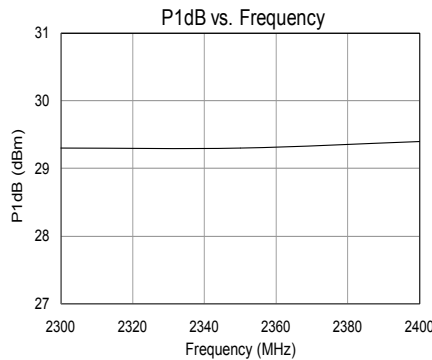
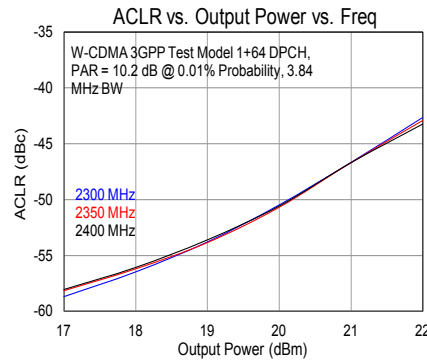
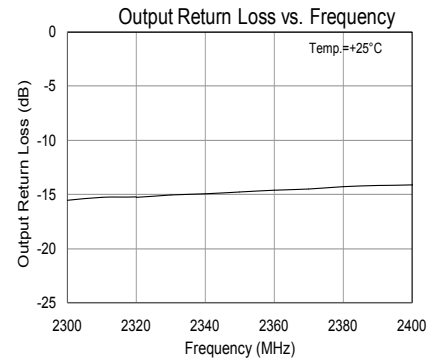
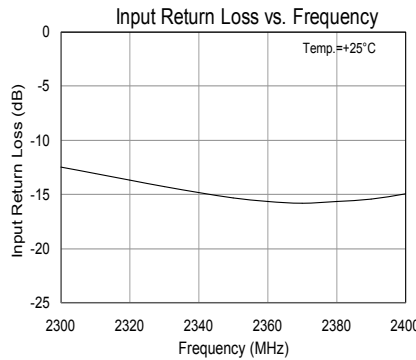
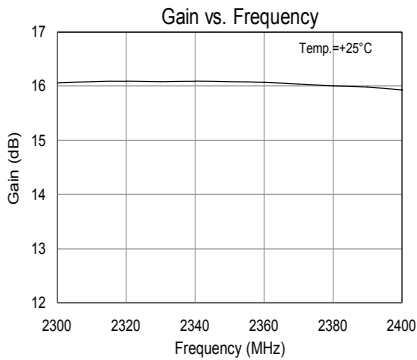

Pin Configuration and Description

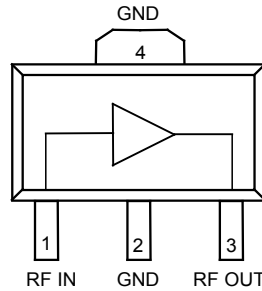

Pin	Symbol	Description
1	RF IN	RF Input. Requires external match for optimal performance. External DC Block required.
2, 4	GND	RF/DC Ground Connection
3	RFout / Vcc	RF Output. Requires external match for optimal performance. External DC Block and supply voltage is required.

Applications Information

PC Board Layout

PCB Material (stackup):

- 1 oz. Cu top layer
- 0.014 inch Nelco N-4000-13, $\epsilon_r=3.7$
- 1 oz. Cu MIDDLE layer 1
- Core Nelco N-4000-13
- 1 oz. Cu middle layer 2
- 0.014 inch Nelco N-4000-13
- 1 oz. Cu bottom layer
- Finished board thickness is 0.062±.006

50 ohm line dimensions: width = .028", spacing = .028".

The pad pattern shown has been developed and tested for optimized assembly at TriQuint Semiconductor. The PCB land pattern has been developed to accommodate lead and package tolerances. Since surface mount processes vary from supplier to supplier, careful process development is recommended.

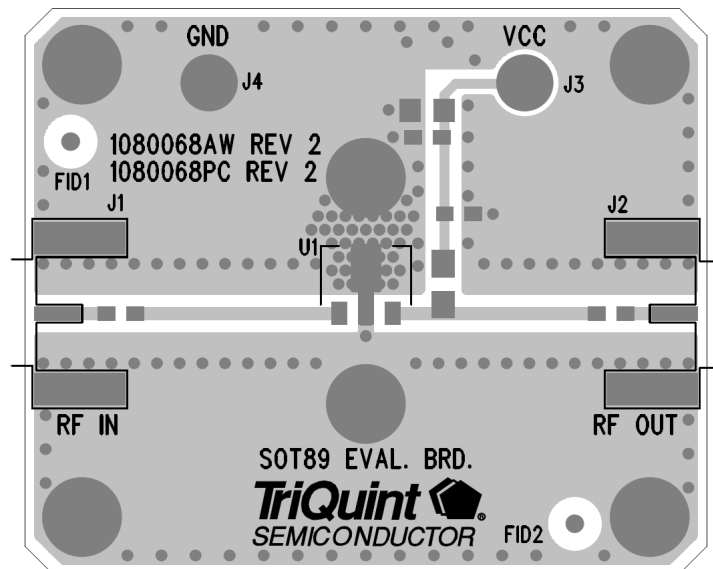

Mechanical Information

Package Information and Dimensions

This package is lead-free/RoHS-compliant. The plating material on the leads is NiPdAu. It is compatible with both lead-free (maximum 260 °C reflow temperature) and lead (maximum 245 °C reflow temperature) soldering processes.

The component will be marked with a “7M9103” designator with an alphanumeric lot code on the top surface of package.

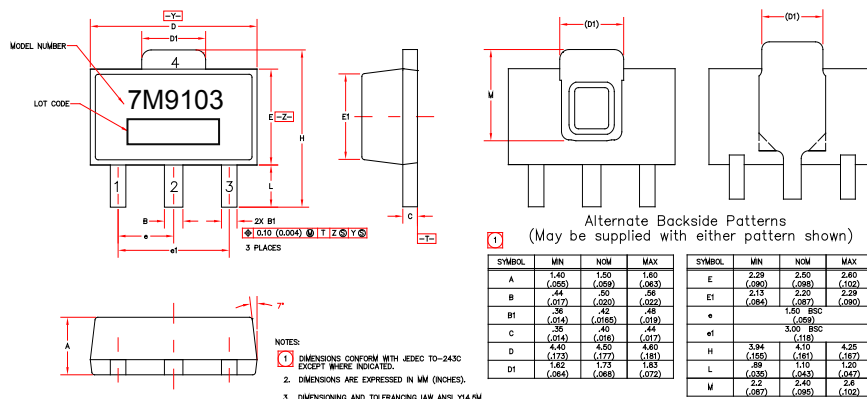

Mounting Configuration

All dimensions are in millimeters (inches). Angles are in degrees.

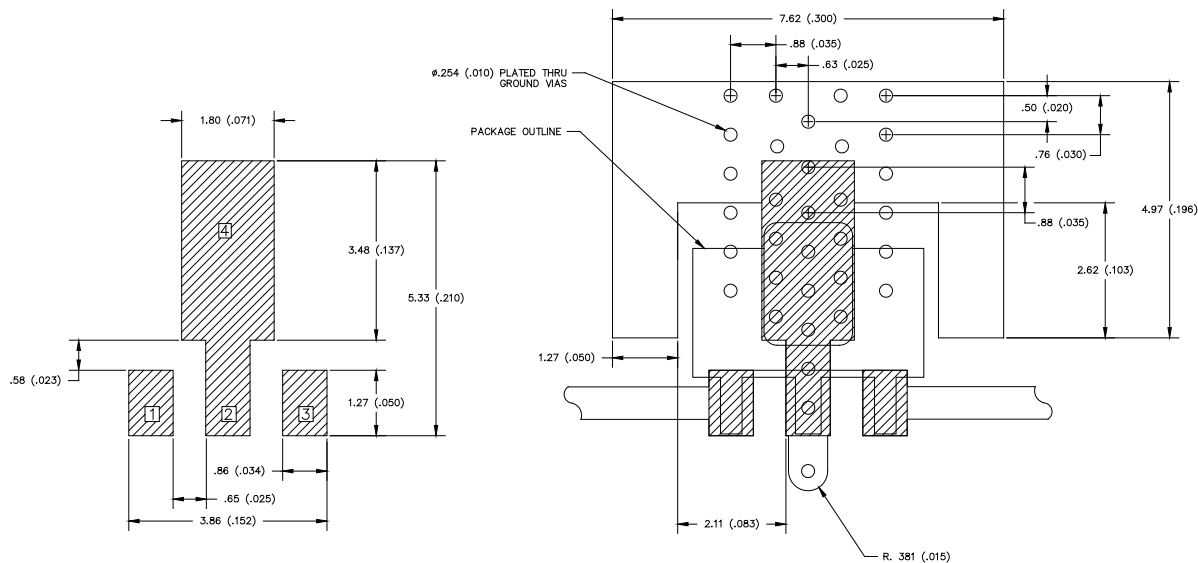

Notes:

1. Ground / thermal vias are critical for the proper performance of this device. Vias should use a .35mm (#80 / .0135”) diameter drill and have a final plated thru diameter of .25 mm (.010”).
2. Add as much copper as possible to inner and outer layers near the part to ensure optimal thermal performance.
3. RF trace width depends upon the PC board material and construction.
4. Use 1 oz. Copper minimum.

Product Compliance Information

ESD Information



Caution! ESD-Sensitive Device

ESD Rating: Class 2
Value: ≥ 2000 V and < 4000 V
Test: Human Body Model (HBM)
Standard: JEDEC Standard JESD22-A114

ESD Rating: Class IV
Value: ≥ 2000 V min
Test: Charged Device Model (CDM)
Standard: JEDEC Standard JESD22-C101

MSL Rating

Level 3 at +260 °C convection reflow
The part is rated Moisture Sensitivity Level 3 at 260°C per
JEDEC standard IPC/JEDEC J-STD-020.

Solderability

Compatible with the latest version of J-STD-020, Lead free solder, 260°

This part is compliant with EU 2002/95/EC RoHS directive (Restrictions on the Use of Certain Hazardous Substances in Electrical and Electronic Equipment).

This product also has the following attributes:

- Lead Free
- Halogen Free (Chlorine, Bromine)
- Antimony Free
- TBBP-A ($C_{15}H_{12}Br_4O_2$) Free
- PFOS Free
- SVHC Free

Contact Information

For the latest specifications, additional product information, worldwide sales and distribution locations, and information about TriQuint:

Web: www.triquint.com
Email: info-sales@tqs.com

Tel: +1.503.615.9000
Fax: +1.503.615.8902

For technical questions and application information:

Email: sjcapplications.engineering@tqs.com

Important Notice

The information contained herein is believed to be reliable. TriQuint makes no warranties regarding the information contained herein. TriQuint assumes no responsibility or liability whatsoever for any of the information contained herein. TriQuint assumes no responsibility or liability whatsoever for the use of the information contained herein. The information contained herein is provided "AS IS, WHERE IS" and with all faults, and the entire risk associated with such information is entirely with the user. All information contained herein is subject to change without notice. Customers should obtain and verify the latest relevant information before placing orders for TriQuint products. The information contained herein or any use of such information does not grant, explicitly or implicitly, to any party any patent rights, licenses, or any other intellectual property rights, whether with regard to such information itself or anything described by such information.

TriQuint products are not warranted or authorized for use as critical components in medical, life-saving, or life-sustaining applications, or other applications where a failure would reasonably be expected to cause severe personal injury or death.