

TQM700013

Band 13 LTE PA Module



Applications

- LTE Compatible Applications

Product Features

- Small 10-pin 3x3mm module
- Integrated high performance coupler
- Built-in Vreg functionality eliminating the need for external components
- Low quiescent current provides excellent talk-time
- Excellent linearity
- TriQuint's GaAs BiHEMT / CuFlip® PA Technology
- Optimized for 50Ω system
- Lead-free 260°C / RoHS / Halogen-free

General Description

The TQM700013 is fully matched Power Amplifier Module designed for use in LTE handsets. Its compact 3x3mm package (including coupler) makes it ideal for today's extremely small data enabled phones. Its RF performance meets the stringent linearity requirements of LTE operation.

The TQM700013 is designed on TriQuint's GaAs BiHEMT technology with CuFlip® assembly offering state of the art reliability, temperature stability and ruggedness. The module includes built-in regulator functionality as well as a high performance coupler for maximum integration and space savings.

Functional Block Diagram

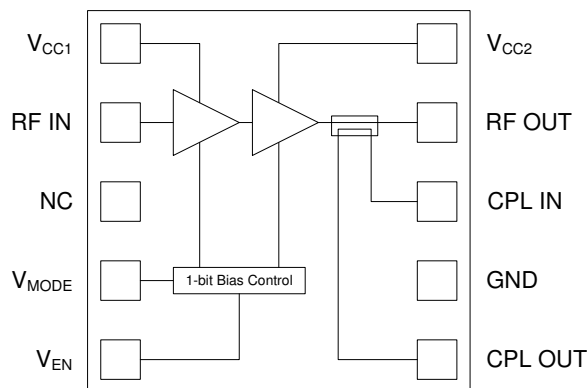

Electrical Specifications

Parameter	Typ	Unit
Max P _{OUT}	27.5	dBm
E-UTRA ACLR	-40	dBc
UTRA ACLR1	-40	dBc
UTRA ACLR2	-60	dBc
LPM I _{CQ}	11	mA
Max Power Current	430	mA
Rx Noi e	-130	dBm/Hz

Note: Typical performance for LTE, V_{CC1} = V_{CC2} = 3.4VDC, V_{EN} = HIGH, T_C = 25°C

Ordering Information

Part No.	Description
TQM700013	Band 13 LTE PAM

Standard T/R size = 2,500 pieces on a 7" reel.