

# TAT8801A1H

## 75 Ω CATV Output Stage Amplifier

### Applications

- CATV Line Amplifiers
- HFC Nodes
- Head End Equipment

### Product Features

- Wide Bandwidth (40 MHz – 1 GHz)
- 100% production tested for 80 ch. NTSC.
- Low distortion variation over temperature and production volumes
- In-package ESD protection
- Flat Gain
- High Power Compression
- Excellent Input/Output Match
- Low DC Power Consumption
- Bias optimization through external voltage

### General Description

The TAT8801A1H is an ultra-linear, packaged GaAs MMIC amplifier, intended for output stage amplification in CATV infrastructure applications.

The TAT8801A1H features a single die design, and provides flat gain along with low distortion, making them ideal for use in CATV distribution systems, requiring high output powers and low distortion.

The TAT8801A1H draws 585 mA from a 12 V supply, while allowing users to adjust the bias current and the bias voltage externally in order to optimize output performance.

The TAT8801A1H integrates two TQP200002 ESD protection dies, which deliver bi-directional protection with very low leakage currents and extremely low capacitance.

The TAT8801A1H also includes a common mode tuning element within the package that allows for improved second order distortion performance.

The TAT8801A1H is packaged in an industry standard 16 pin SOIC WB package.

Please visit [www.triquint.com](http://www.triquint.com) for more details on the TQP200002 device.



16-pin SOIC Wide Body Package with backside ground paddle

### Functional Block Diagram

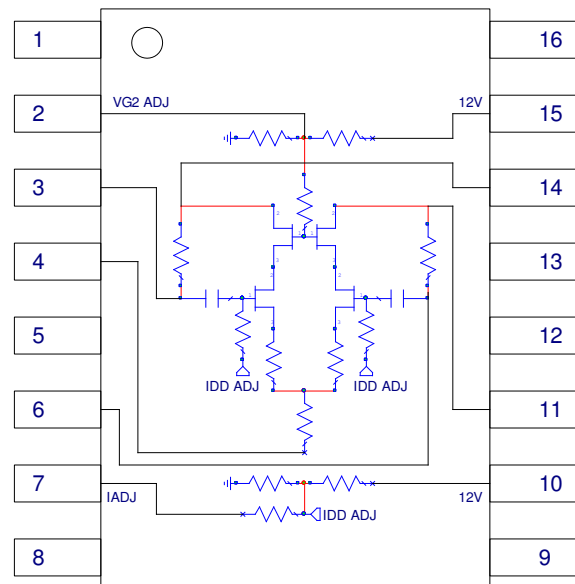

Pin 4 may be grounded to PCB using an RF bead or an inductor to further improve CSO performance.

### Pin Description

Pin #	Symbol
1, 5, 8-9, 12-13, 16	N/C
4	SP TUNE
2	VG2 ADJ
3 / 6	RFIN1 / RFIN2
7	IDD ADJ
10	VDD
11 / 14	RFOUT2 / RFOUT1
15	VDD

### Ordering Information

Part No.	Description
TAT8801A1H	CATV Output Stage Amplifier
TAT8801A1H-PCB	CATV Output Stage Amplifier Evaluation Board

Standard T/R size = 1000 pieces on a 7" reel