

Data Sheet

Typical Performance

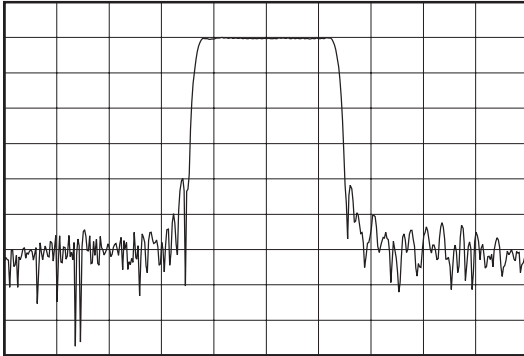

Horizontal: 500 kHz/Div
Vertical: 10 dB/Div

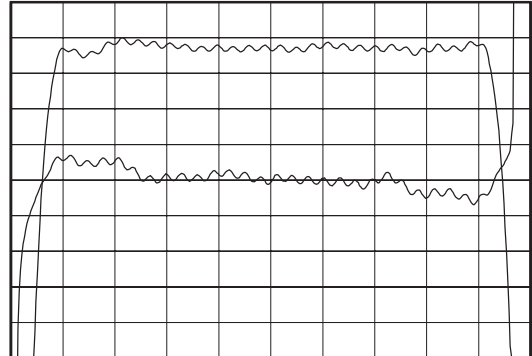

Horizontal: 150 kHz/Div
Vertical: 1 dB/Div
Vertical: 5 deg/Div

Specifications

Parameter	Unit	Minimum	Typical	Maximum
Center Frequency	MHz	-	70	-
Insertion Loss at F_0	dB	-	19	22
Lower 1.5 dB Point	MHz	-	69.355	69.37
Upper 1.5 dB Point	MHz	70.63	70.645	-
Lower 35 dB Point	MHz	69.25	69.263	-
Upper 35 dB Point	MHz	-	70.737	70.75
Passband Ripple	dB	-	0.6	0.7
Phase Linearity ¹	deg	-	2	5
Ultimate Rejection @ ± 0.900 MHz	dB	50	55	-
Triple Transit Suppression	dB	30	40	-
Substrate Material	-	-	Quartz	-
Temperature Range	$^{\circ}$ C	-5	25	65

Package Outline

Matching Configuration

Note1) Deviation From Linear Over Center 1.23 MHz Bandwidth

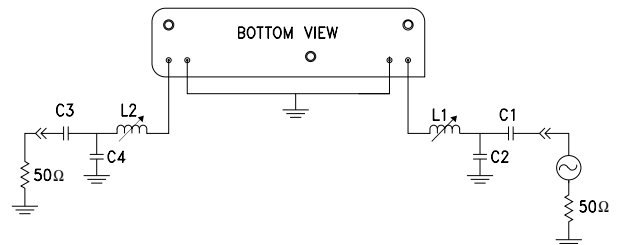
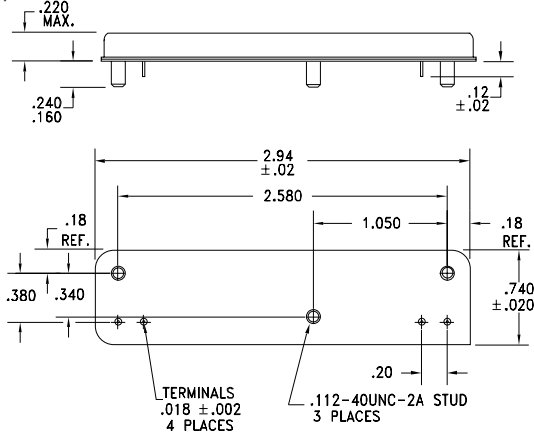

$L1 \approx 280$ nH , $L2 \approx 280$ nH , $C1 = 12$ pF
 $C2 = 22$ pF, $C3 = 22$ pF, $C4 = 12$ pF
Nominal Source/Load Impedance = 50Ω
Package Style V

11/30/99