

Data Sheet

Features

- For WLAN applications
- Usable bandwidth 17 MHz
- Single-ended or Balanced operation
- Configurable to 50 Ω and 200 Ω input and output impedance
- Ceramic Surface Mount Package (SMP)
- Hermetic
- RoHS compliant (2002/95/EC), Pb-free 

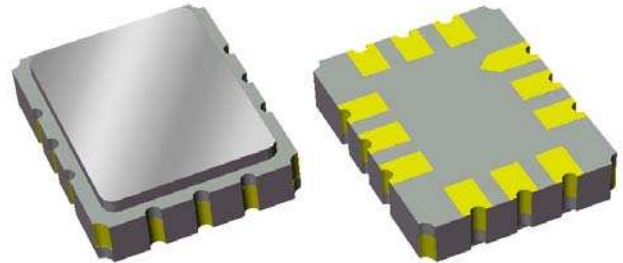

Package Pin Configuration

Surface Mount 7.01 x 5.51 x 1.63 mm

Bottom View

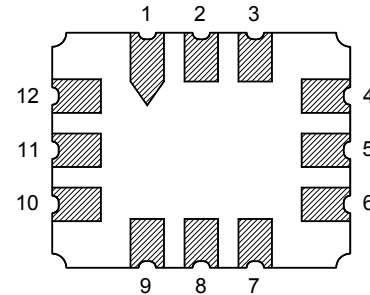
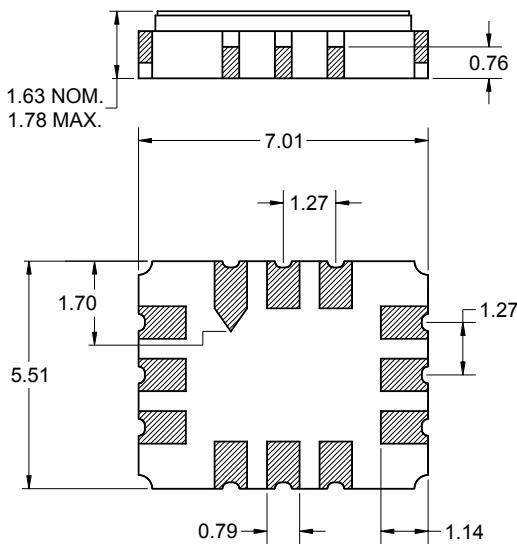

Pin No.	Description
3	Output
4	Output return
9	Input
10	Input return
1,2,5,6	Case ground
7,8,11,12	Case ground

Dimensions shown are nominal in millimeters
 All tolerances are ±0.15mm except overall
 length and width +0.15mm/-0.10mm

Body: Al_2O_3 ceramic
 Lid: Kovar, Ni plated
 Terminations: Au plating 0.5 - 1.0μm,
 over a 2 - 6μm Ni plating

Data Sheet

Electrical Specifications ⁽¹⁾

Operating Temperature Range: ⁽²⁾ -40 to +85 °C

Parameter ⁽³⁾	Minimum	Typical	Maximum	Unit
Center Frequency	-	374	-	MHz
Insertion Loss	-	8.5	11	dB
Lower 3 dB Bandedge	-	362	365.5	MHz
Upper 3 dB Bandedge	382.5	386	-	MHz
Absolute Attenuation				
274 - 341 MHz	50	55	-	dB
341 - 352 MHz	40	60	-	dB
352 - 357.5 MHz	10	50	-	dB
390.5 - 396 MHz	10	37	-	dB
396 - 430 MHz	30	45	-	dB
430 - 474 MHz	45	50	-	dB
Passband Ripple	-	0.6	1	dB p-p
Group Delay Ripple	-	60	100	nsec p-p
Triple Transit Suppression	30	40.5	-	dB
Source Impedance ⁽⁴⁾	-	50	-	Ω
Load Impedance ⁽⁴⁾	-	50	-	Ω
Substrate Material	-	YZ LiNbO ₃	-	-

Notes:

1. All specifications are based on the test circuit shown below
2. In production, devices will be tested at room temperature to a guardbanded specification to ensure electrical compliance over temperature
3. Electrical margin has been built into the design to account for the variations due to temperature drift and manufacturing tolerances
4. This is the optimum impedance in order to achieve the performance shown
5. Sawtek's production specifications reflect the typical performance in a 50 ohm single-ended system. This filter can be used in both single-ended and/or differential modes at each port. In addition, similar performance can be achieved in source and load impedances ranging from 50 to 500 ohms.

Test Circuit:

Actual matching values may vary due to PCB layout and parasitics

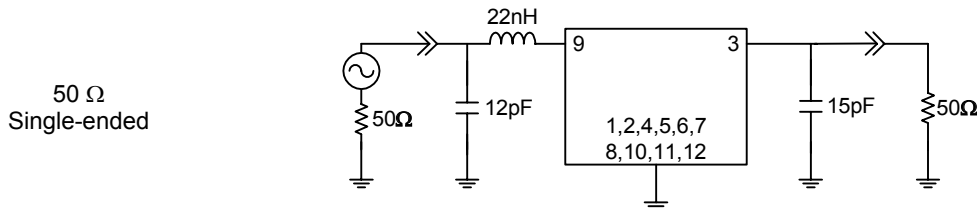

Data Sheet

Typical Performance (at +25°C) (50Ω Input/Output)

Frequency Response

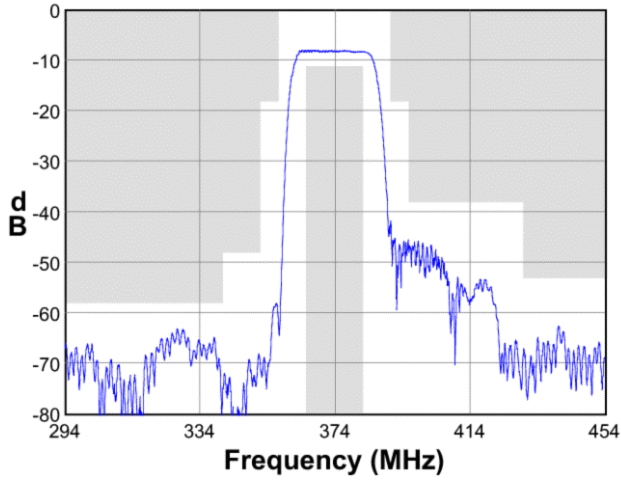

Passband Response

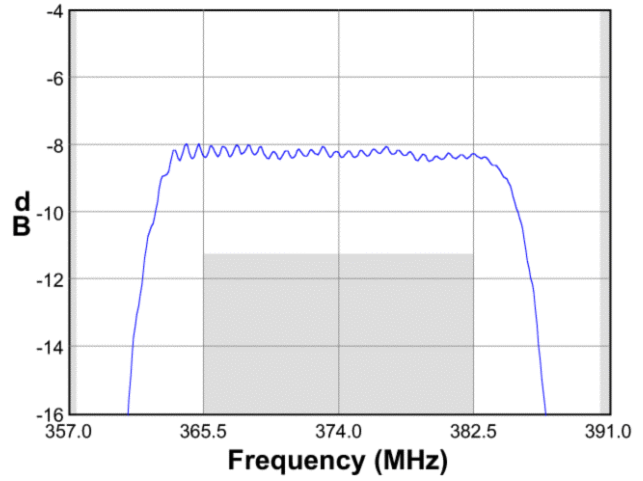

Wideband Response

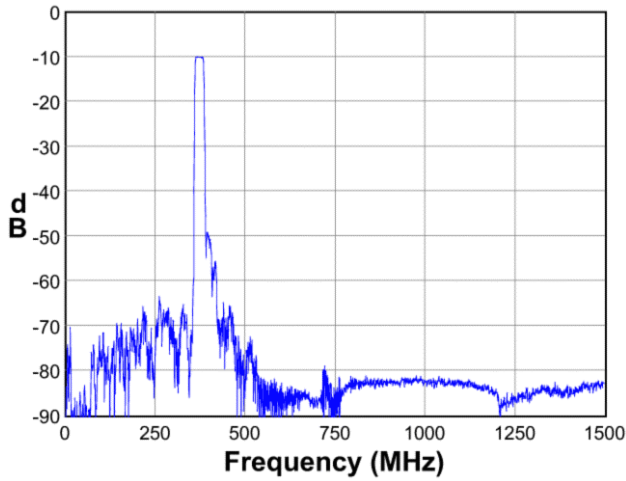

Group Delay

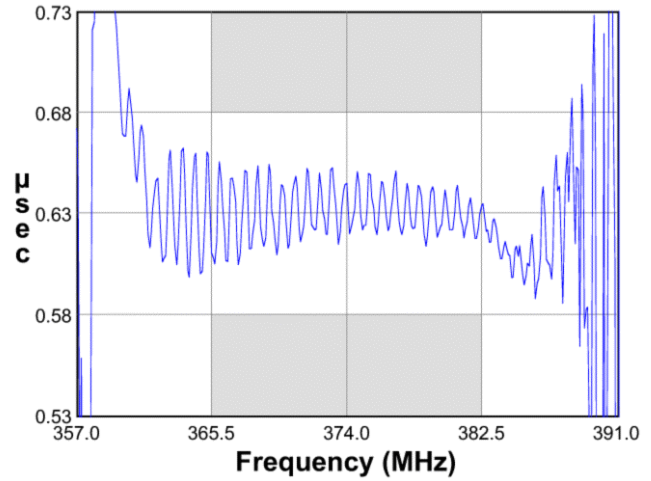

Input Smith Chart

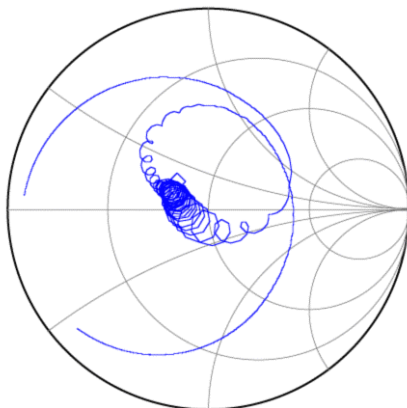

Output Smith Chart

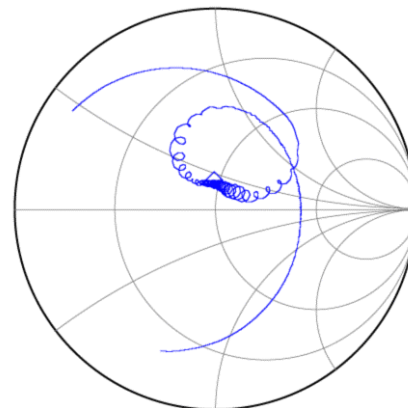

Data Sheet

Matching Schematics

Actual matching values may vary due to PCB layout and parasitics

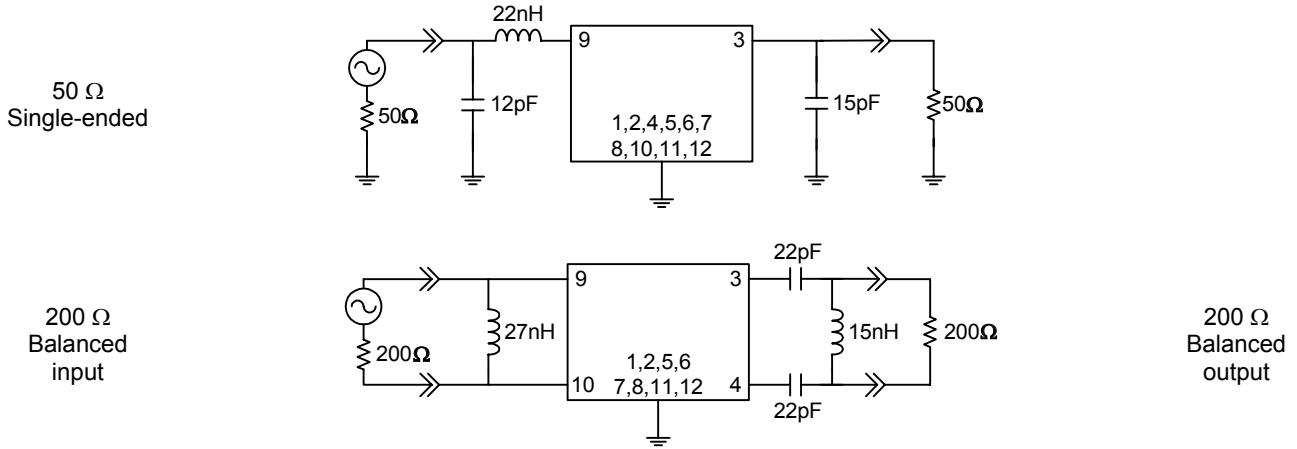

Marking



The date code consists of: day of the current year (Julian, 3 digits), last digit of the year (1 digit) and hour (2 digits)

PCB Footprint

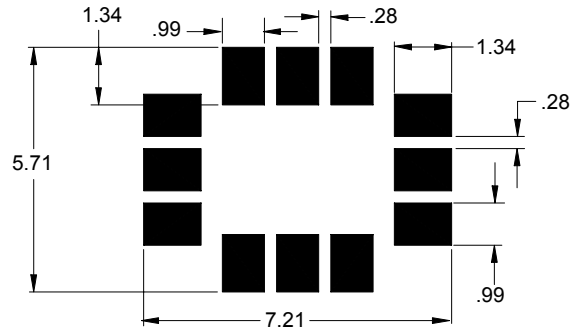

This footprint represents a recommendation only
Dimensions shown are nominal in millimeters

Tape and Reel

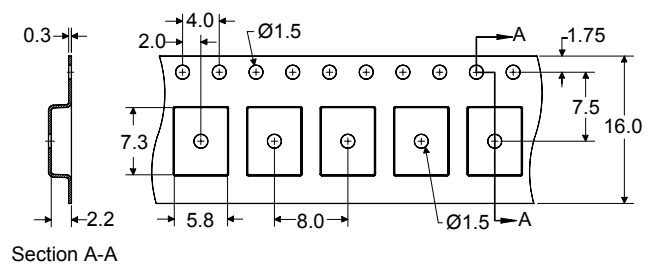
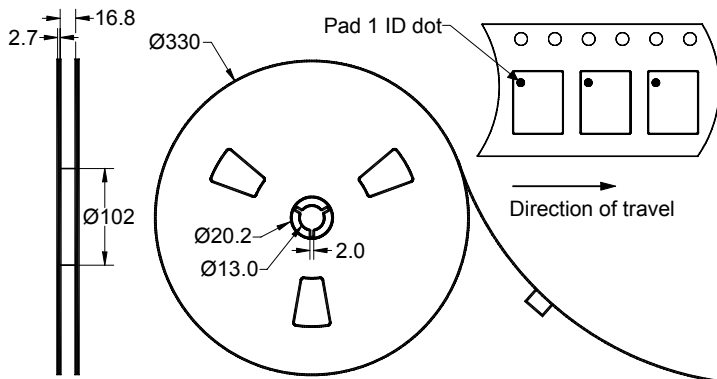

Dimensions shown are nominal in millimeters
Packaging quantity: 3000 units/reel

Data Sheet

Maximum Ratings

Parameter	Symbol	Minimum	Maximum	Unit
Operating Temperature Range	T	-40	+85	°C
Storage Temperature Range	T _{stg}	-40	+85	°C

Important Notes

Warnings

- Electrostatic Sensitive Device (ESD) 
- Avoid ultrasonic exposure

RoHS Compliance

- This product complies with EU directive 2002/95/EC (RoHS) 

Solderability

- Compatible with JEDEC J-STD-020C **Pb**-free process, **260°C** peak reflow temperature ([see soldering profile](#))

Links to Additional Technical Information

[PCB Layout Tips](#)

[Qualification Flowchart](#)

[Soldering Profile](#)

[S-Parameters](#)

[RoHS Information](#)

[Other Technical Information](#)

Sawtek's liability is limited only to the Surface Acoustic Wave (SAW) component(s) described in this data sheet. Sawtek does not accept any liability for applications, processes, circuits or assemblies, which are implemented using any Sawtek component described in this data sheet.

Contact Information



PO Box 609501
 Orlando, FL 32860-9501
 USA

Phone: +1 (407) 886-8860
 Fax: +1 (407) 886-7061
 Email: custservice@sawtek.com
 Web: www.sawtek.com

Or contact one of our worldwide
 Network of [sales offices](#),
[representatives or distributors](#)