

PRELIMINARY DATA SHEET

AS179-000: GaAs SPDT Switch 300 kHz–3 GHz Medium Power

Applications

- General-purpose medium-power switch in telecommunication applications
- Transceiver transmit-receive switch in 802.11b/g WLAN, etc., systems

Features

- Broadband: 300 kHz–3 GHz
- Low insertion loss: 0.3 dB @ 900 MHz
- High isolation: 25 dB @ 900 MHz
- $P_{1\text{ dB}}$: 30 dBm @ 3 V control voltage
- IP3: 43 dBm @ 3 V control voltage
- Low DC power consumption
- 100% RF tested in die form
- Lead (Pb)-free, RoHS-compliant, and Green™
- ESD Class 1A

Description

The AS179-000 is a monolithic SPDT switch, fabricated using Skyworks proprietary GaAs PHEMTs as the switching elements. This wideband switch operates with RF signals from 300 kHz–3 GHz. The RF signal paths within the AS179-000 are bilateral. The J_1 and J_2 RF input/output terminals are reflective.

Switching is controlled via a pair of high impedance control voltage inputs. Depending upon the logic voltage level applied to the control voltage pins, the common RF pin (J_1) is connected to one of two switched RF pins (J_2 or J_3) via a low insertion loss path, while the path between the RF common and the other RF pin is in its high-isolation state.

DC power consumption is very low, 100 μ A nominal with control voltage of 3 V. The switch can operate over the temperature range of -40° C to +85° C.

NEW



Skyworks Green™ products are RoHS (Restriction of Hazardous Substances)-compliant, conform to the EIA/EICTA/JEITA Joint Industry Guide (JIG) Level A guidelines, are halogen free according to IEC-61249-2-21, and contain <1,000 ppm antimony trioxide in polymeric materials.

Preliminary Data Sheet: Based on engineering results. Sampling quantities available. Pin out and package have been determined.

Functional Block Diagram

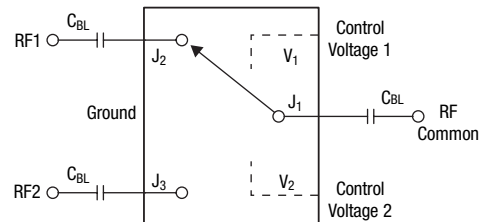

DC blocks required on all RF ports for positive control voltage operation.

Absolute Maximum Ratings

Characteristic	Value
RF input power ($V_{CTL} = 0\text{ V}/7\text{ V}$)	6 W, $f > 500\text{ MHz}$ 2 W, $100 > f > 500\text{ MHz}$ 315 mW, $f = 300\text{ kHz}^{(1)}$
Control voltage range	-0.2 V V_C +8 V
Operating temperature range	-40 °C to +85 °C
Storage temperature range	-40 °C to +150 °C

1. Derate linearly for 300 kHz < f < 100 MHz.

Performance is guaranteed only under the conditions listed in the specifications table and is not guaranteed under the full range(s) described by the Absolute Maximum specifications. Exceeding any of the absolute maximum/minimum specifications may result in permanent damage to the device and will void the warranty.

CAUTION: Although this device is designed to be as robust as possible, ESD (Electrostatic Discharge) can damage this device. This device must be protected at all times from ESD. Static charges may easily produce potentials of several kilovolts on the human body or equipment, which can discharge without detection. Industry-standard ESD precautions must be employed at all times.

Electrical Specifications at 25 °C

$V_{CTL} = 0\text{ V/3 V}$, $T = 25\text{ °C}$, $P_{INPUT} = 0\text{ dBm}$, $Z_0 = 50\ \Omega$, unless otherwise noted

Parameter	Frequency	Min.	Typ.	Max.	Unit
Insertion loss	300 kHz–1 GHz		0.30	0.4	dB
	1–2 GHz		0.30	0.4	dB
	2–3 GHz		0.35	0.5	dB
Isolation	300 kHz–1 GHz	22	25		dB
	1–2 GHz	20	22		dB
	2–3 GHz	20	22		dB
VSWR ⁽¹⁾	300 kHz–3 GHz		1.1:1	1.3:1	

1. Insertion loss state.

Operating Characteristics at 25 °C

$V_{CTL} = 0\text{ V/3 V}$, $T = 25\text{ °C}$, $P_{INPUT} = 0\text{ dBm}$, $Z_0 = 50\ \Omega$, unless otherwise noted

Parameter	Condition	Frequency	Min.	Typ.	Max.	Unit
Switching characteristics						
Rise, fall	10/90% or 90/10% RF			10		ns
On, off	50% CTL to 90/10% RF			20		ns
Video feedthru	$T_{RISE} = 1\text{ ns}$, $BW = 500\text{ MHz}$			25		mV
Input power for 1 dB compression ($IP_1\text{ dB}$)	$V_{CTL} = 0/3\text{ V}$	0.5–3 GHz		30		dBm
	$V_{CTL} = 0/5\text{ V}$	0.5–3 GHz		34		dBm
Input Intermodulation intercept point (IIP3)	For two-tone input power 5 dBm $V_{CTL} = 0/3\text{ V}$ $V_{CTL} = 0/5\text{ V}$	0.5–3 GHz		43		dBm
		0.5–3 GHz		50		dBm
Thermal resistance				15		°C/W
Control voltage	V_{HIGH}		3		5	V
	V_{LOW}		0		0.2	V
Control port current	$V_{CTL} = 5\text{ V}$				100	μA
	$V_{CTL} = 0\text{ V}$				20	μA

Typical Performance Data

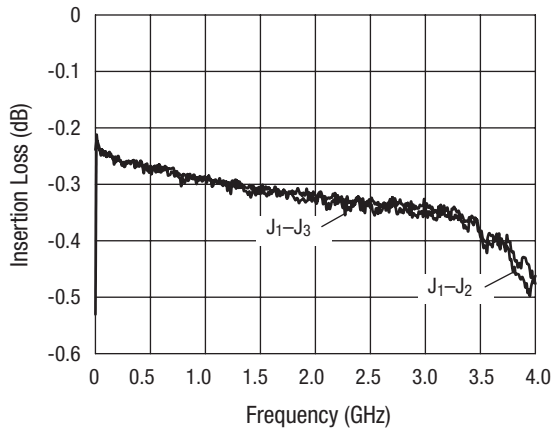

Insertion Loss vs. Frequency

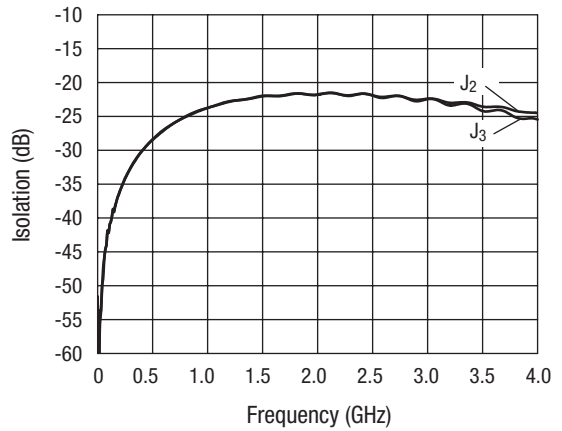

Isolation vs. Frequency

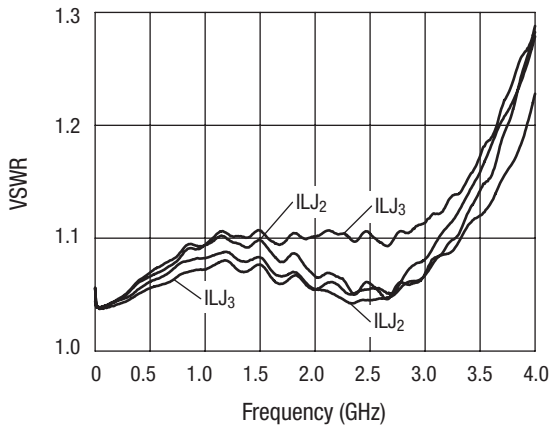

VSWR vs. Frequency

Die Outline

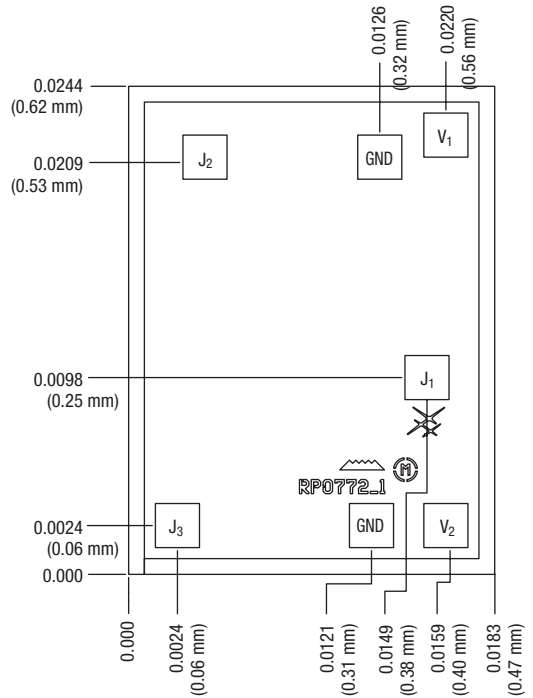

Bond-pad dimensions: 0.0022 (0.06 mm) square.
 Bond-pad metallization: Gold.
 Backside metallization: None.
 Die thickness 0.008 ± 0.001 (0.203 ± 0.025).
 Dimensions in inches (mm).

Port Descriptions

Parameter	Description
J ₁	RF Common — RF input/output port that is connected via low impedance path to either RF1 or RF2, depending upon the voltage applied to control voltage pin. External DC block required for positive control voltages.
J ₂ , J ₃	RF Input/Output — RF input/output port that is connected via low impedance path to either RF common (J ₁) or to ground, depending upon the voltage levels applied to control voltage pins. External DC block required for positive control voltages.
V ₁ , V ₂	Control Voltage Inputs — Combination of voltage logic levels applied to these pins determines the state of the RF paths between J ₁ and J ₂ /J ₃ .
GND	Ground — Should be down-bonded to circuit ground

Truth Table

V _{CTL1}	V _{CTL2}	J ₁ -J ₂	J ₁ -J ₃
V _{HIGH}	0	Isolation	Insertion loss
0	V _{HIGH}	Insertion loss	Isolation
0	0	Not allowed	Not allowed
V _{HIGH}	V _{HIGH}	Not allowed	Not allowed

Theory of Operation

The AS179-000 Single Pole Double Throw (SPDT) switch comprises two RF signal paths, one of which connects the RF common pin (J₁) to RF1 (J₂) and the other connects RF common to RF2 (J₃). Depending upon the logic voltage levels applied to the control voltage pins (V₁ and V₂), one of these paths is in its minimum insertion loss state while the other is in its high-isolation state. When these logic levels are toggled, the state of each of the paths toggles accordingly.

Starting at the RF common pin, each signal path is comprised of a depletion mode PHEMT, Q2 or Q3, in series with the signal path, followed by another depletion mode PHEMT, Q1 or Q4, in shunt with the signal path. A HI logic level applied to the control voltage pin V₁ and a low logic level applied to the control voltage pin V₂ forces the path between RF common and RF1 into its high-isolation state and the other path, from RF common to RF2, into its low insertion loss state.

The shunt PHEMT to common, Q1 or Q4, is biased to produce minimum impedance when the signal path of which it is part is placed into its isolation state. Consequently, the magnitude of the reflection coefficient looking into this pin is close to 1, that is, the VSWR looking into that port approaches infinity.

The AS179-000 can operate with control voltage from 3 V up to 5 V.

The logic threshold voltage for the control voltage pin is one half of the minimum high control voltage. The impedance looking into each of the control voltage pins is several tens of kilohms. For positive control voltage, DC blocks are required on each RF port.

Simplified Block Diagram

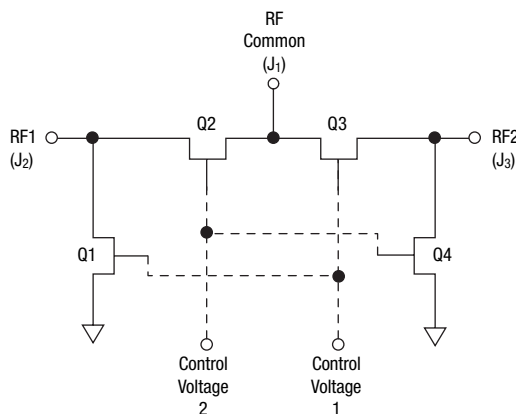

Applications

The AS179-000 SPDT switch can be used in a number of ways: it can be used to select one of two loads; it can also be used to alternately connect an antenna to a radio transmitter and receiver, etc.

Transmit-Receive Switch

A SPDT switch can be used as a transmit-receive (TR) switch, to alternately connect a transmitter and a receiver to a single antenna in a single duplex system.

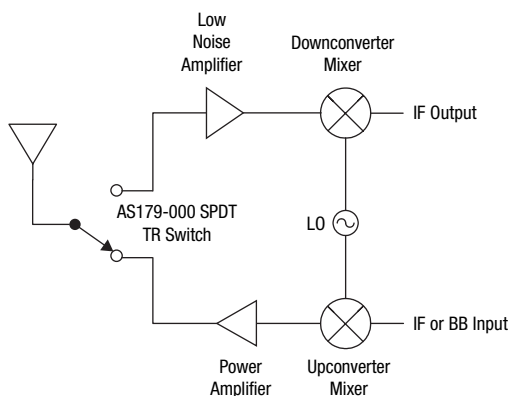

Copyright © 2002, 2003, 2004, 2005, 2006, 2007, 2008, Skyworks Solutions, Inc. All Rights Reserved.

Information in this document is provided in connection with Skyworks Solutions, Inc. ("Skyworks") products or services. These materials, including the information contained herein, are provided by Skyworks as a service to its customers and may be used for informational purposes only by the customer. Skyworks assumes no responsibility for errors or omissions in these materials or the information contained herein. Skyworks may change its documentation, products, services, specifications or product descriptions at any time, without notice. Skyworks makes no commitment to update the materials or information and shall have no responsibility whatsoever for conflicts, incompatibilities, or other difficulties arising from any future changes.

No license, whether express, implied, by estoppel or otherwise, is granted to any intellectual property rights by this document. Skyworks assumes no liability for any materials, products or information provided hereunder, including the sale, distribution, reproduction or use of Skyworks products, information or materials, except as may be provided in Skyworks Terms and Conditions of Sale.

THE MATERIALS, PRODUCTS AND INFORMATION ARE PROVIDED "AS IS" WITHOUT WARRANTY OF ANY KIND, WHETHER EXPRESS, IMPLIED, STATUTORY, OR OTHERWISE, INCLUDING FITNESS FOR A PARTICULAR PURPOSE OR USE, MERCHANTABILITY, PERFORMANCE, QUALITY OR NON-INFRINGEMENT OF ANY INTELLECTUAL PROPERTY RIGHT; ALL SUCH WARRANTIES ARE HEREBY EXPRESSLY DISCLAIMED. SKYWORKS DOES NOT WARRANT THE ACCURACY OR COMPLETENESS OF THE INFORMATION, TEXT, GRAPHICS OR OTHER ITEMS CONTAINED WITHIN THESE MATERIALS. SKYWORKS SHALL NOT BE LIABLE FOR ANY DAMAGES, INCLUDING BUT NOT LIMITED TO ANY SPECIAL, INDIRECT, INCIDENTAL, STATUTORY, OR CONSEQUENTIAL DAMAGES, INCLUDING WITHOUT LIMITATION, LOST REVENUES OR LOST PROFITS THAT MAY RESULT FROM THE USE OF THE MATERIALS OR INFORMATION, WHETHER OR NOT THE RECIPIENT OF MATERIALS HAS BEEN ADVISED OF THE POSSIBILITY OF SUCH DAMAGE.

Skyworks products are not intended for use in medical, lifesaving or life-sustaining applications, or other equipment in which the failure of the Skyworks products could lead to personal injury, death, physical or environmental damage. Skyworks customers using or selling Skyworks products for use in such applications do so at their own risk and agree to fully indemnify Skyworks for any damages resulting from such improper use or sale.

Customers are responsible for their products and applications using Skyworks products, which may deviate from published specifications as a result of design defects, errors, or operation of products outside of published parameters or design specifications. Customers should include design and operating safeguards to minimize these and other risks. Skyworks assumes no liability for applications assistance, customer product design, or damage to any equipment resulting from the use of Skyworks products outside of stated published specifications or parameters.

Skyworks, the Skyworks symbol, and "Breakthrough Simplicity" are trademarks or registered trademarks of Skyworks Solutions, Inc., in the United States and other countries. Third-party brands and names are for identification purposes only, and are the property of their respective owners. Additional information, including relevant terms and conditions, posted at www.skyworksinc.com, are incorporated by reference.