

# Data Sheet

## Features

- For wireless LAN applications
- Usable bandwidth of 10 MHz
- High attenuation
- Single-ended operation at 50Ω
- Ceramic Surface Mount Package (SMP)
- Small size

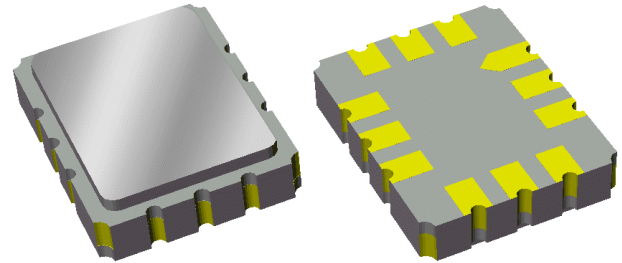

## Package

Surface Mount 7.01 x 5.51 x 1.63 mm

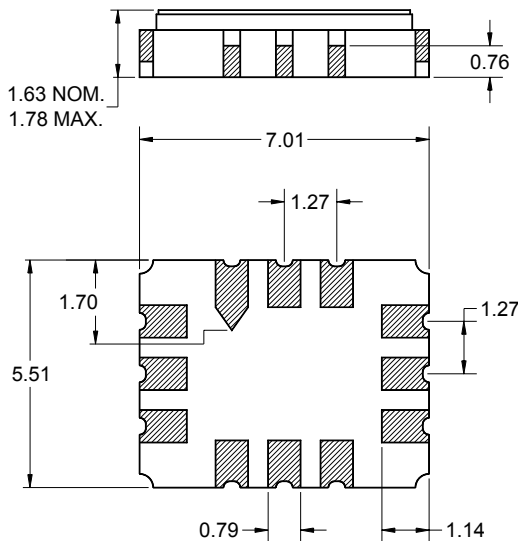

Dimensions shown are nominal in millimeters  
 All tolerances are  $\pm 0.15$ mm except overall  
 length and width  $\pm 0.13$ mm

Body:  $Al_2O_3$  ceramic  
 Lid: Kovar, Ni plated  
 Terminations: Au plating 0.5 - 1.0 $\mu$ m,  
 over a 2 - 6 $\mu$ m Ni plating

## Pin Configuration

Bottom View

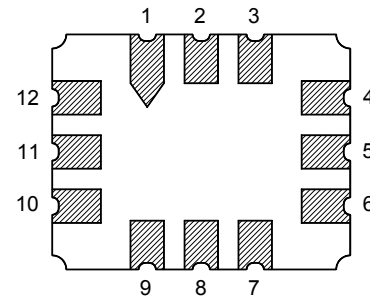

Pin No.	Description
4	Output
10	Input
1,2,3,5,6	Case Ground
7,8,9,11,12	Case Ground

# Data Sheet

## Electrical Specifications <sup>(1)</sup>

Temperature Range: <sup>(2)</sup> -10 to +65 °C

Parameter <sup>(3)</sup>	Minimum	Typical	Maximum	Unit
<b>Center Frequency</b>	-	549.5	-	MHz
<b>Insertion Loss at 549.5 MHz</b>	-	11.8	14	dB
<b>1 dB Lower Frequency</b> <sup>(4)</sup>	-	542.6	544.5	MHz
<b>1 dB Upper Frequency</b>	554.5	556.4	-	MHz
<b>3 dB Lower Frequency</b> <sup>(4)</sup>	541	541.9	543	MHz
<b>3 dB Upper Frequency</b>	556	557.1	558	MHz
<b>40 dB Lower Frequency</b> <sup>(4)</sup>	536.5	539.2	-	MHz
<b>40 dB Upper Frequency</b>	-	560.3	562.5	MHz
<b>Relative Attenuation</b> <sup>(4)</sup>				
10 - 523.5 MHz	50	56	-	dB
523.5 - 536.5 MHz	40	47	-	dB
562.5 - 575.5 MHz	40	48	-	dB
575.5 - 2000 MHz	50	55	-	dB
<b>Passband Variation</b>				
544.5 - 554.5 MHz	-	0.26	1	dB p-p
<b>Passband Variation</b> <sup>(5)</sup>				
544.5 - 554.5 MHz	-	0.25	0.8	dB p-p
<b>Phase Ripple</b> <sup>(5)</sup>				
544.5 - 554.5 MHz (straight line fit)	-	1.9	5	deg p-p
<b>Group Delay Variation</b>				
544.5 - 554.5 MHz	-	30	100	nsec
<b>Input/Output VSWR</b>				
544.5 - 554.5 MHz	-	1.4	2	
<b>Triple Transit Level</b>	35	42	-	dB
<b>Source Impedance</b> <sup>(6)</sup>	-	50	-	Ω
<b>Load Impedance</b> <sup>(6)</sup>	-	50	-	Ω
<b>Temperature Coefficient of Frequency</b>	-	-23	-	ppm/°C

### Notes:

1. All specifications are based on the matching schematic on page 4
2. In production, devices will be tested at room temperature to a guardbanded specification to ensure electrical compliance over temperature
3. Electrical margin has been built into the design to account for the variations due to manufacturing tolerances
4. Referenced to insertion loss at 549.5 MHz
5. Sliding aperture 2 MHz
6. This is the optimum impedance in order to achieve the performance shown

**Data Sheet**

**Typical Performance (at +25°C)**

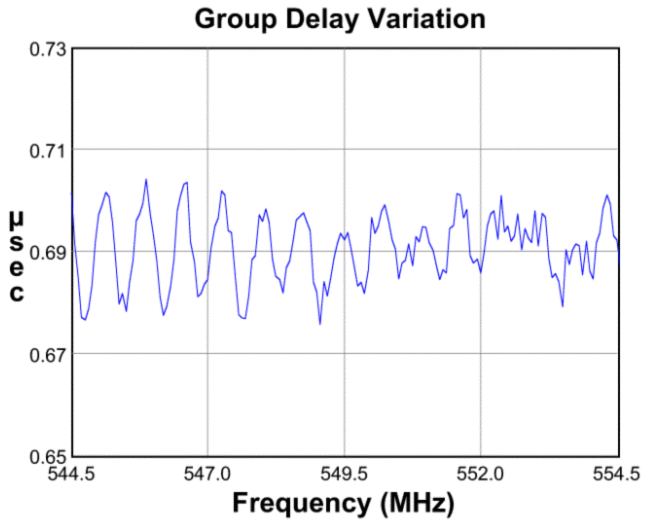
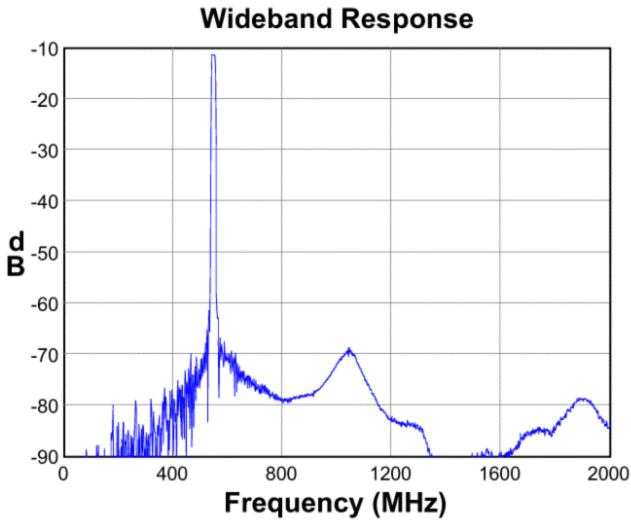
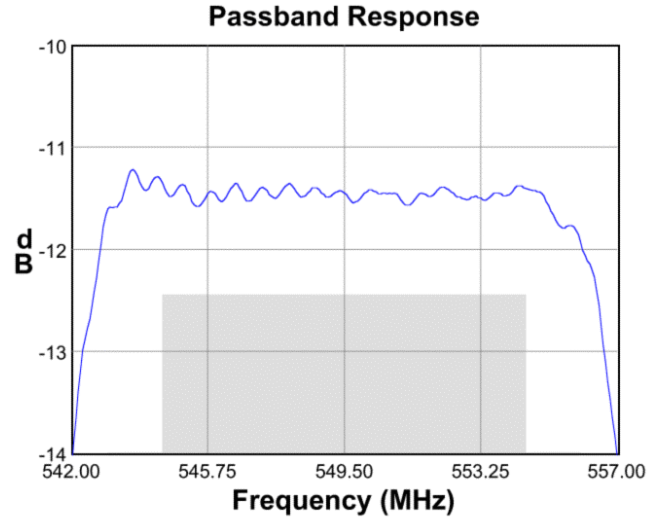
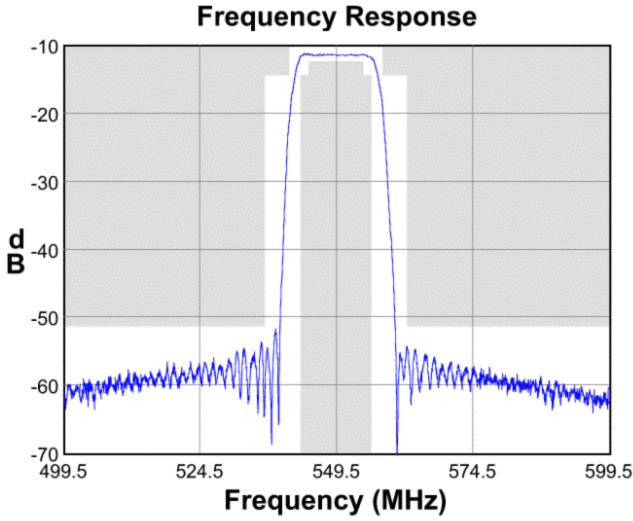

**Input Smith Chart**

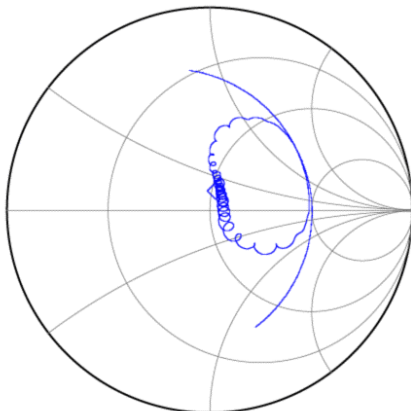

**Output Smith Chart**

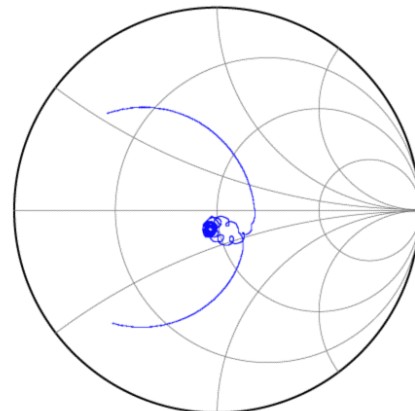

**Data Sheet**

**Test Circuit**

Actual matching values may vary due to PCB layout and parasitics

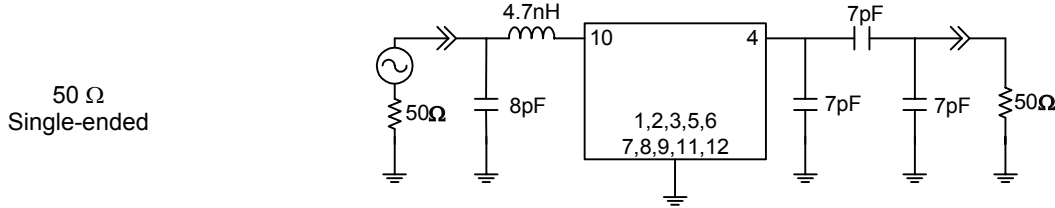

**Matching Schematics**

Actual matching values may vary due to PCB layout and parasitics

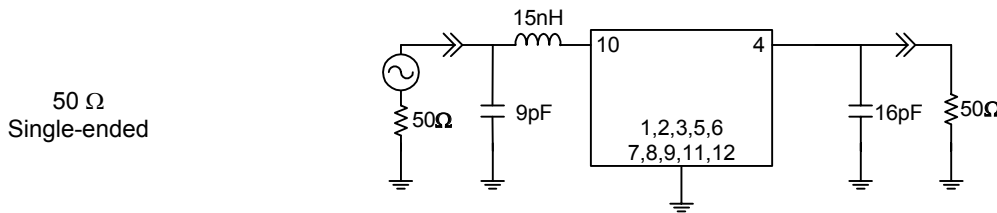

**Marking**



The date code consists of: day of the current year (Julian, 3 digits), last digit of the year (1 digit) and hour (2 digits)

**PCB Footprint**

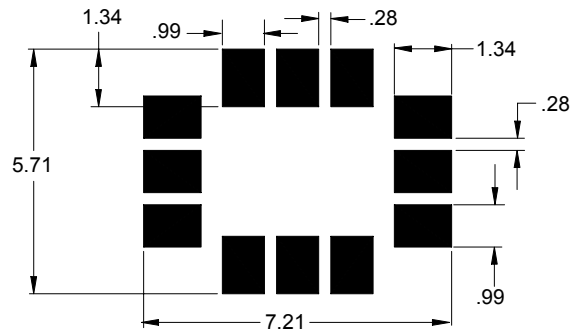

This footprint represents a recommendation only  
Dimensions shown are nominal in millimeters

**Tape and Reel**

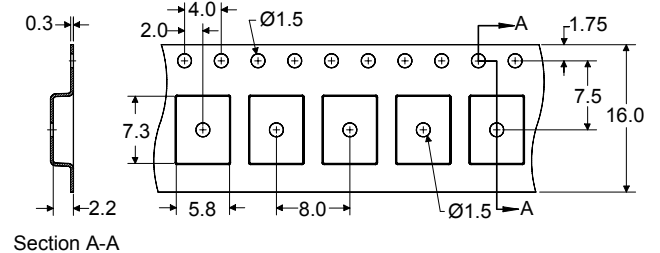
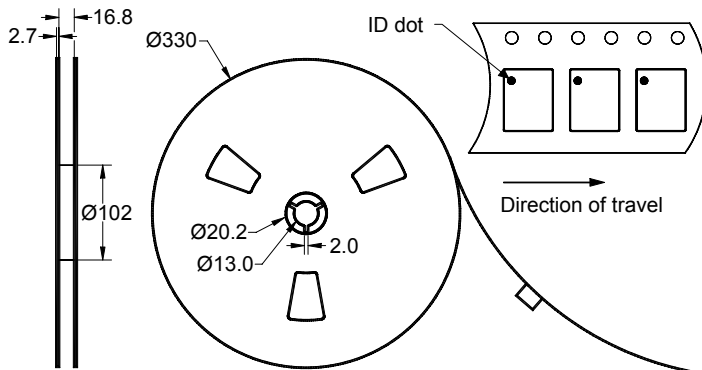

Dimensions shown are nominal in millimeters  
Packaging quantity: 3000 units/reel

# Data Sheet

## Maximum Ratings

Parameter	Symbol	Minimum	Maximum	Unit
Operating Temperature Range	T	-10	+65	°C
Storage Temperature Range	T <sub>stg</sub>	-40	+85	°C

### Warnings

- Electrostatic Sensitive Device (ESD) 
- Avoid ultrasonic exposure

## Links to Additional Technical Information

[PCB Layout Tips](#)

[Qualification Flowchart](#)

[Soldering Profile](#)

[S-Parameters](#)

[Other Technical Information](#)

Sawtek's liability is limited only to the Surface Acoustic Wave (SAW) component(s) described in this data sheet. Sawtek does not accept any liability for applications, processes, circuits or assemblies which are implemented using any Sawtek component described in this data sheet.

## Contact Information



PO Box 609501  
 Orlando, FL 32860-9501  
 USA

Phone: +1 (407) 886-8860  
 Fax: +1 (407) 886-7061  
 Email: [custservice@sawtek.com](mailto:custservice@sawtek.com)  
 Web: [www.sawtek.com](http://www.sawtek.com)

Or contact one of our worldwide network of [sales offices](#), [representatives or distributors](#)