

**Features**

- For WiMAX/WiBRO/fixed wireless applications
- Usable bandwidth of 7.25 MHz
- Typical 1 dB bandwidth of 9.2 MHz
- High attenuation
- Impedance matching required
- Balanced operation
- Ceramic Surface Mount Package (SMP)
- Hermetic
- RoHS compliant (2002/95/EC), Pb-free 

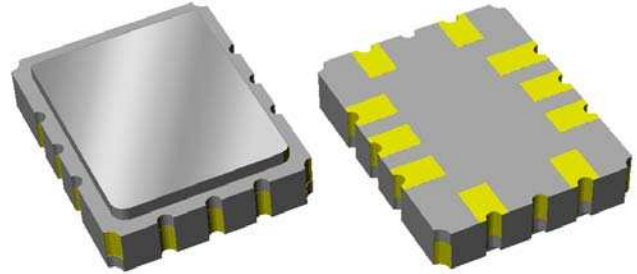

**Package**

Surface Mount 7.00 x 5.50 x 1.24 mm

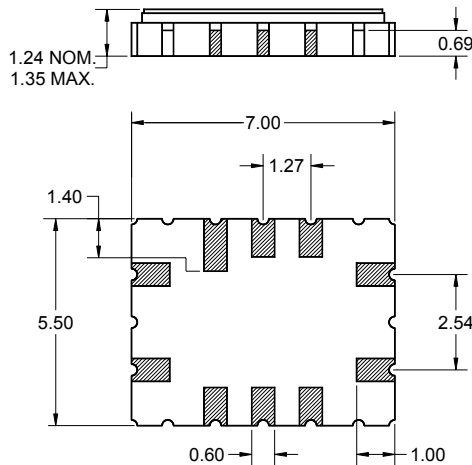

**Pin Configuration**

Bottom View

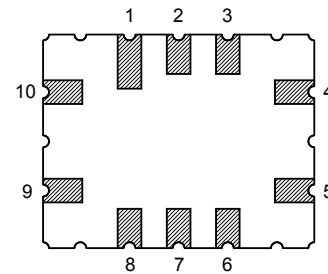

Pin No.	Description
4	Output
5	Output return
9	Input
10	Input return
1,2,3	Case ground
6,7,8	Case ground

Dimensions shown are nominal in millimeters  
All tolerances are  $\pm 0.15$ mm except overall  
length and width  $\pm 0.13$ mm

Body:  $Al_2O_3$  ceramic  
Lid: Kovar, Ni plated  
Terminations: Au plating 0.5 - 1.0 $\mu$ m,  
over a 2 - 6 $\mu$ m Ni plating

**Electrical Specifications <sup>(1)</sup>**

Operating Temperature Range: <sup>(2)</sup> -40 to +85 °C

Parameter <sup>(3)</sup>	Minimum	Typical	Maximum	Unit
Center Frequency, $F_o$	-	380	-	MHz
Insertion Loss at $F_o$	-	10	12	dB
1 dB Lower Frequency <sup>(4)</sup>	-	375.4	376.375	MHz
1 dB Upper Frequency	383.625	384.6	-	MHz
3 dB Lower Frequency <sup>(4)</sup>	-	374.9	375	MHz
3 dB Upper Frequency	384	385.1	-	MHz
15 dB Lower Frequency <sup>(4)</sup>	372.75	373.9	-	MHz
15 dB Upper Frequency	-	386.1	387.25	MHz
40 dB Lower Frequency <sup>(4)</sup>	370	372.5	-	MHz
40 dB Upper Frequency	-	387.5	390	MHz
Passband Variation <sup>(5)</sup> 376.375 - 383.625 MHz	-	0.2	1	dB p-p
Average Group Delay 376.375 - 383.625 MHz	-	0.75	0.85	µs
Group Delay Variation 376.375 - 383.625 MHz	-	26	100	ns
Optimal Source Impedance <sup>(6)</sup>	-	100	-	Ω
Optimal Load Impedance <sup>(6)</sup>	-	100	-	Ω

**Notes:**

1. All specifications are based on the test circuit shown below
2. In production, devices will be tested at room temperature to a guardbanded specification to ensure electrical compliance over temperature
3. Electrical margin has been built into the design to account for the variations due to manufacturing tolerances
4. Relative to insertion loss at  $F_o$
5. Passband variation is defined as the difference between the lowest loss and the highest loss within the passband. The edge of the passband is the point where the amplitude begins a downward trend that does not reverse until the stopband
6. This is the optimum impedance in order to achieve the performance shown

**Test Circuit:**

Actual matching values may vary due to PCB layout and parasitics

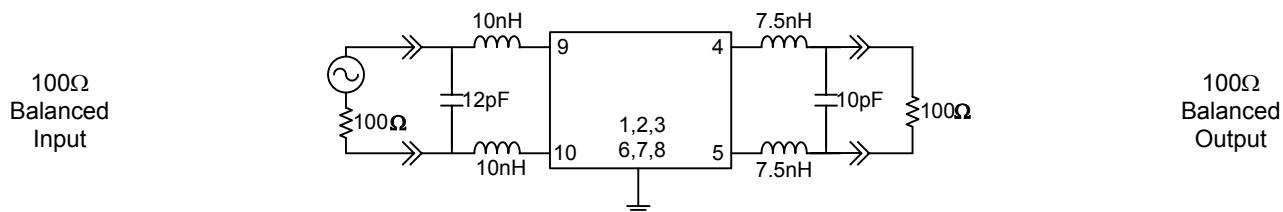

**Typical Performance (at +25°C)**

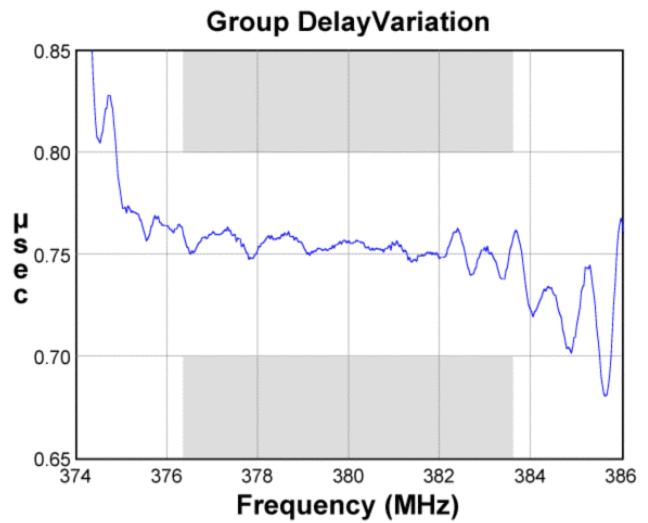
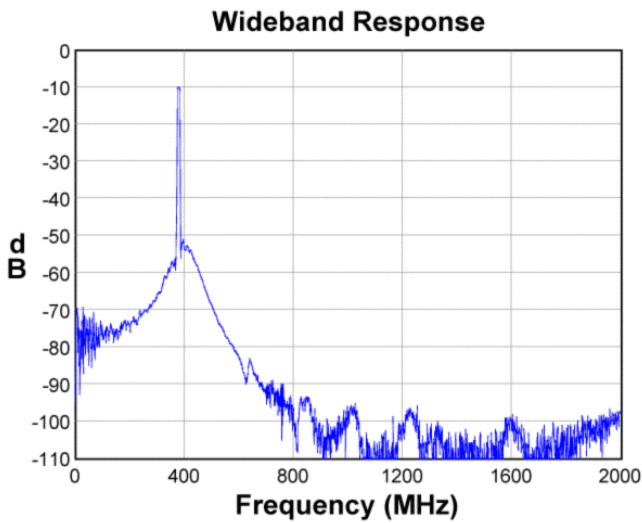
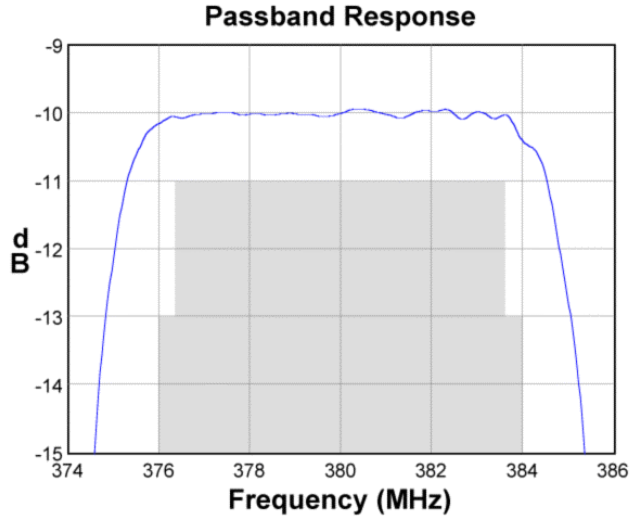
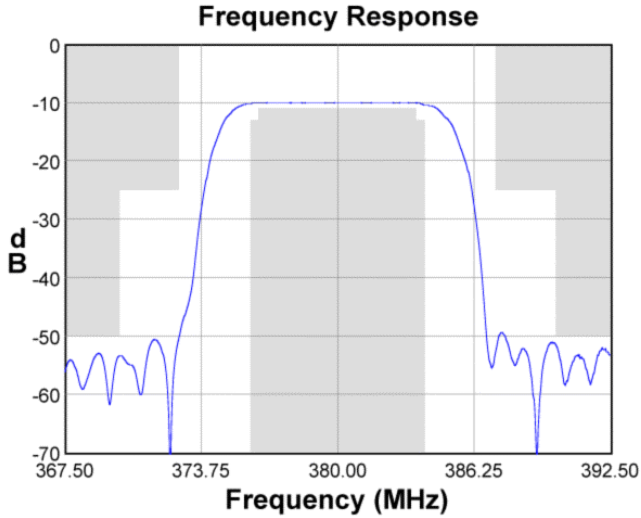

**Input Smith Chart**

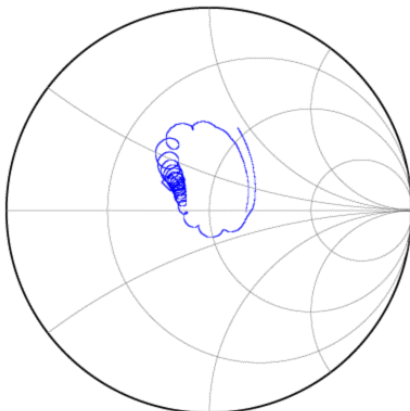

**Output Smith Chart**

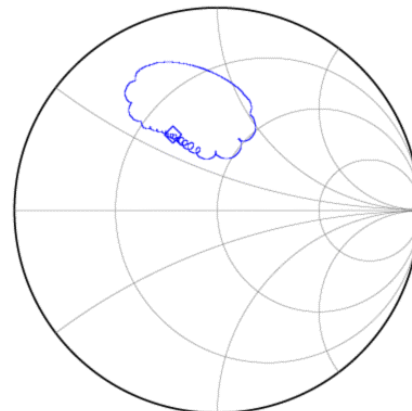

**Matching Schematics**

Actual matching values may vary due to PCB layout and parasitics

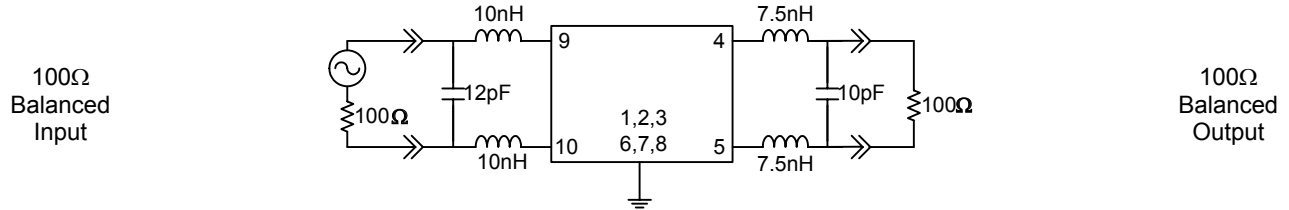

**Marking**

**PCB Footprint**

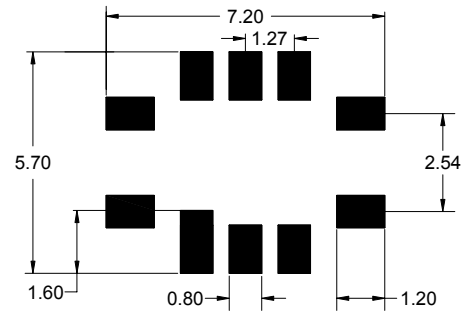
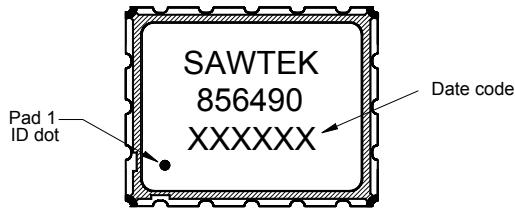

The date code consists of: day of the current year (Julian, 3 digits), last digit of the year (1 digit) and hour (2 digits)

This footprint represents a recommendation only  
Dimensions shown are nominal in millimeters

**Tape and Reel**

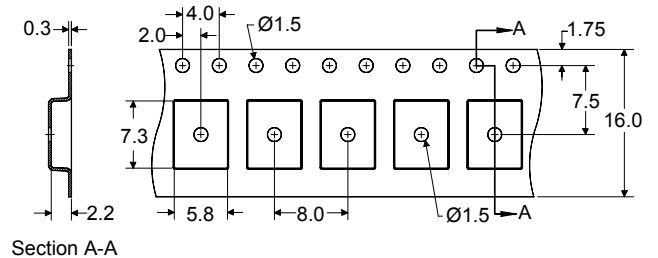
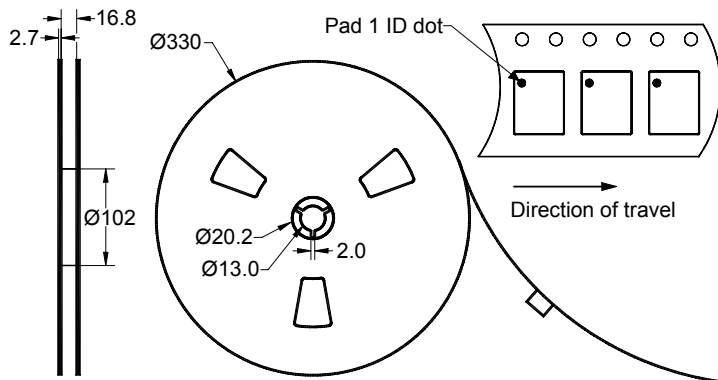

Dimensions shown are nominal in millimeters  
Packaging quantity: 3000 units/reel

**Data Sheet**

**Maximum Ratings**

Parameter	Symbol	Minimum	Maximum	Unit
Operating Temperature Range	T	-40	+85	°C
Storage Temperature Range	T <sub>stg</sub>	-40	+85	°C

**Important Notes**

**Warnings**

- Electrostatic Sensitive Device (ESD) 
- Avoid ultrasonic exposure

**RoHS Compliance**

- This product complies with EU directive 2002/95/EC (RoHS) 

**Solderability**

- Compatible with JEDEC J-STD-020C **Pb**-free process, **260°C** peak reflow temperature ([see soldering profile](#))

**Links to Additional Technical Information**

[PCB Layout Tips](#)

[Qualification Flowchart](#)

[Soldering Profile](#)

[S-Parameters](#)

[RoHS Information](#)

[Other Technical Information](#)

TriQuint's liability is limited only to the Surface Acoustic Wave (SAW) component(s) described in this data sheet. TriQuint does not accept any liability for applications, processes, circuits or assemblies, which are implemented using any TriQuint component described in this data sheet.

**Contact Information**



PO Box 609501  
Orlando, FL 32860-9501  
USA

Phone: +1 (407) 886-8860  
Fax: +1 (407) 886-7061  
Email: [custservice@tqs.com](mailto:custservice@tqs.com)  
Web: [www.triquint.com](http://www.triquint.com)

Or contact one of our worldwide  
Network of [sales offices](#),  
[Representatives or distributors](#)