

## Features

- For WiMAX applications
- Usable bandwidth 10 MHz
- Low loss
- Balanced operation
- Ceramic Surface Mount Package (SMP)
- Hermetic
- RoHS compliant (2002/95/EC), Pb-free 

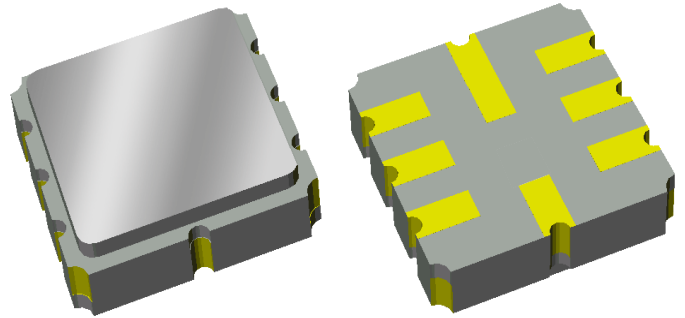

## Package

Surface Mount 5.00 x 5.00 x 1.32 mm  
SMP-20

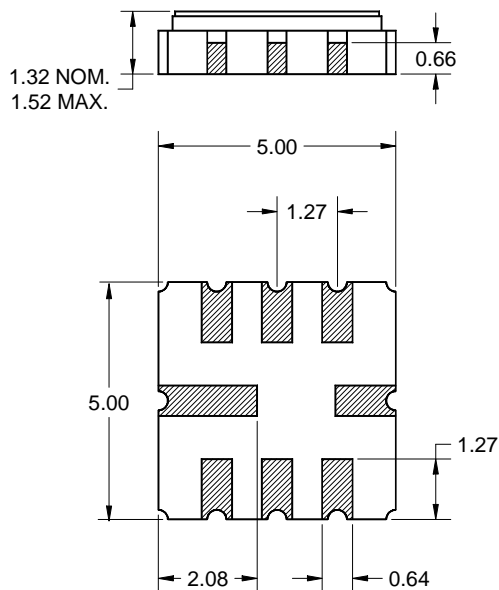

## Pin Configuration

Bottom View

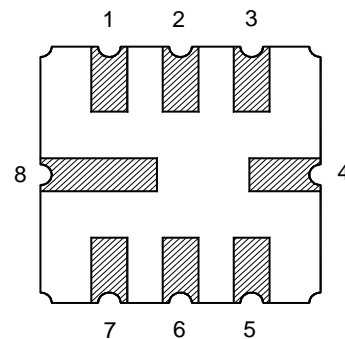

### Balanced Configuration

Pin No.	Description
1	Input +
2	Input -
5	Output +
6	Output -
3,4,7,8	Case Ground

Dimensions shown are nominal in millimeters  
All tolerances are  $\pm 0.15$ mm except overall  
length and width  $+0.15/-0.10$ mm

Body:  $Al_2O_3$  ceramic  
Lid: Kovar, Ni plated  
Terminations: Au plating 0.5 - 1.0 $\mu$ m,  
over a 2 - 6 $\mu$ m Ni plating

**Electrical Specifications <sup>(1)</sup>**

Operating Temperature Range: <sup>(2)</sup> 0 to +70 °C

Parameter <sup>(3)</sup>	Minimum	Typical <sup>(4)</sup>	Maximum	Unit
Center Frequency	-	398	-	MHz
Insertion Loss at Center Frequency	-	8.7	12.5	dB
Lower 1.5 dB Band Edge <sup>(5)</sup>	-	392.4	393	MHz
Upper 1.5 dB Band Edge <sup>(5)</sup>	403	403.7	-	MHz
Lower 35 dB Band Edge <sup>(5)</sup>	388	388.9	-	MHz
Upper 35 dB Band Edge <sup>(5)</sup>	-	406.9	408	MHz
Amplitude Ripple 393 – 403 MHz	-	0.7	1.2	dB
Group Delay Variation 393 – 403 MHz	-	44	60	ns p-p
Ultimate Rejection <sup>(5)</sup>				
10 – 348 MHz	40	49	-	dB
348 – 385 MHz	35	45	-	dB
385 – 388 MHz	35	46	-	dB
408 – 411 MHz	35	40	-	dB
411 – 448 MHz	35	41	-	dB
448 – 1000 MHz	33	35	-	dB
Source Impedance (balanced) <sup>(6)</sup>	-	200	-	Ω
Load Impedance (balanced) <sup>(6)</sup>	-	200	-	Ω

**Notes:**

1. All specifications are based on the TriQuint test circuit shown below
2. In production, devices will be tested at room temperature to a guardbanded specification to ensure electrical compliance over temperature
3. Electrical margin has been built into the design to account for the variations due to temperature drift and manufacturing tolerances
4. Typical values are based on average measurements at room temperature
5. Relative to insertion loss at center frequency
6. This is the optimum impedance in order to achieve the performance shown

**Test Circuit:**

Actual matching values may vary due to PCB layout and parasitics

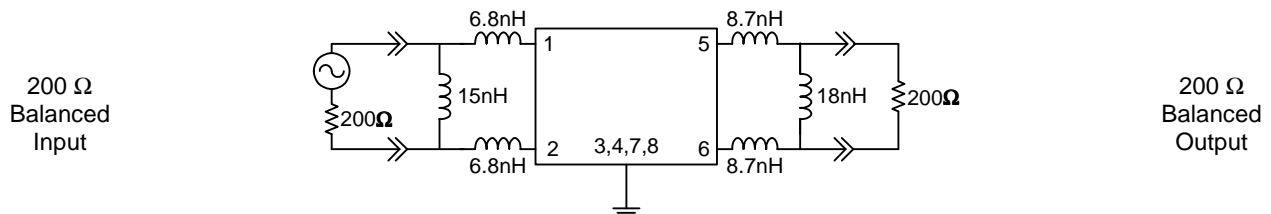

**Electrical Specifications <sup>(1)</sup>**

Operating Temperature Range: <sup>(2)</sup> -40 to +85 °C

Parameter <sup>(3)</sup>	Minimum	Typical <sup>(4)</sup>	Maximum	Unit
Center Frequency	-	398	-	MHz
Insertion Loss at Center Frequency	-	8.7	12.5	dB
Lower 2 dB Band Edge <sup>(5)</sup>	-	392.4	393	MHz
Upper 2 dB Band Edge <sup>(5)</sup>	403	403.7	-	MHz
Lower 35 dB Band Edge <sup>(5)</sup>	388	388.9	-	MHz
Upper 35 dB Band Edge <sup>(5)</sup>	-	406.9	408	MHz
Amplitude Ripple 393 – 403 MHz	-	0.7	1.6	dB
Group Delay Variation 393 – 403 MHz	-	44	80	ns p-p
Ultimate Rejection <sup>(5)</sup>				
10 – 348 MHz	40	49	-	dB
348 – 385 MHz	35	45	-	dB
385 – 388 MHz	35	46	-	dB
408 – 411 MHz	35	40	-	dB
411 – 448 MHz	35	41	-	dB
448 – 1000 MHz	33	35	-	dB
Source Impedance (balanced) <sup>(6)</sup>	-	200	-	Ω
Load Impedance (balanced) <sup>(6)</sup>	-	200	-	Ω

**Notes:**

1. All specifications are based on the TriQuint test circuit shown below
2. In production, devices will be tested at room temperature to a guardbanded specification to ensure electrical compliance over temperature
3. Electrical margin has been built into the design to account for the variations due to temperature drift and manufacturing tolerances
4. Typical values are based on average measurements at room temperature
5. Relative to insertion loss at center frequency
6. This is the optimum impedance in order to achieve the performance shown

**Test Circuit:**

Actual matching values may vary due to PCB layout and parasitics

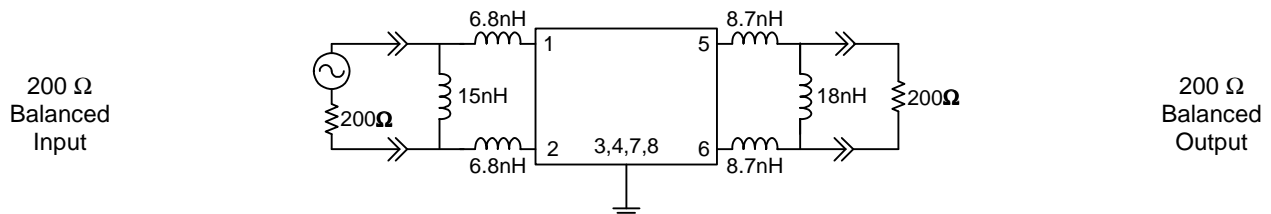

**Typical Performance (at room temperature)**

**Frequency Response**

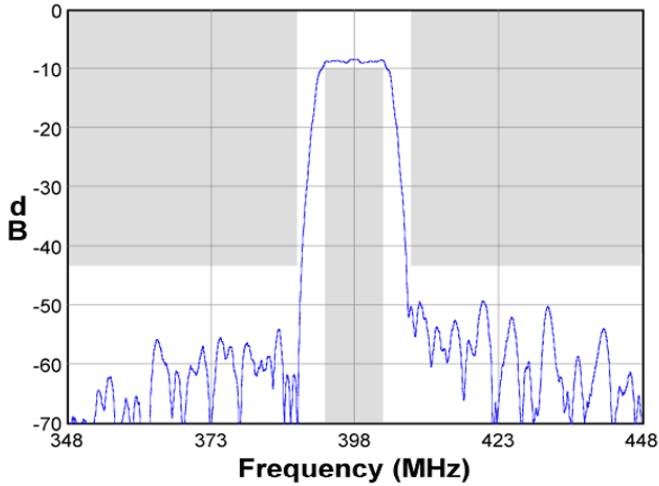

**Passband Response**

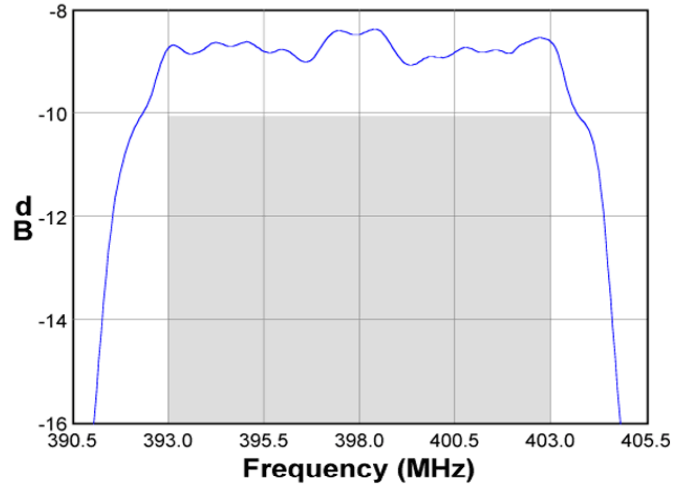

**Wideband Response**

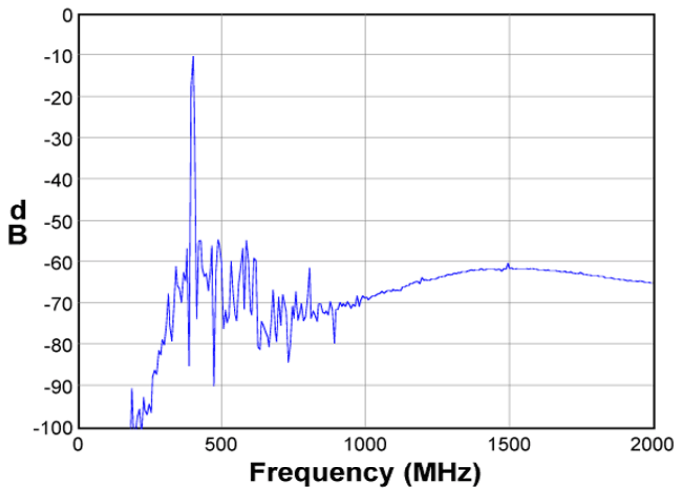

**Group Delay**

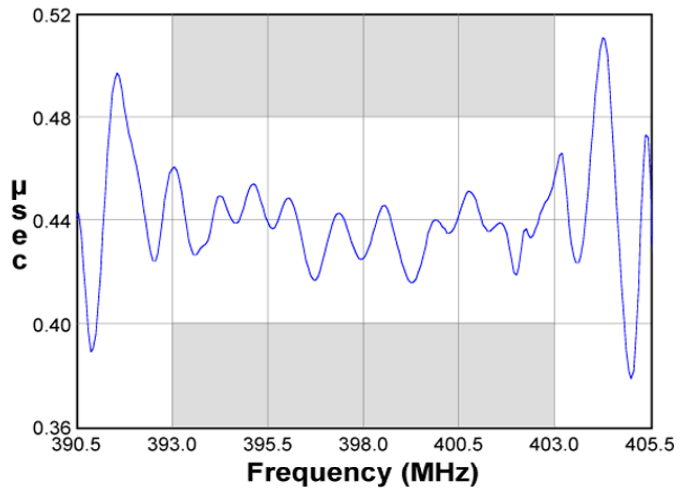

**Input Smith Chart**

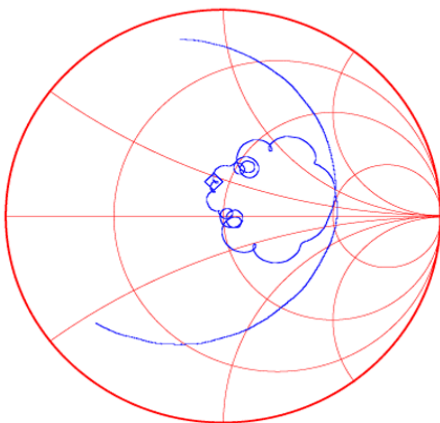

**Output Smith Chart**

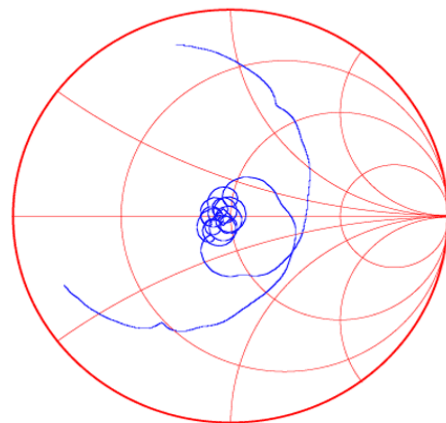

**Matching Schematics**

Actual matching values may vary due to PCB layout and parasitics

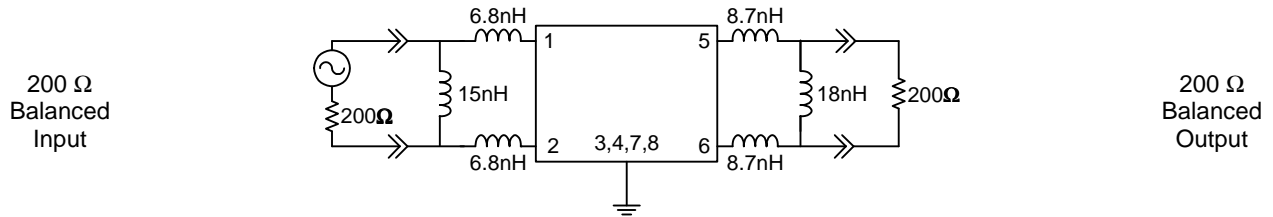

**Marking**

**PCB Footprint**

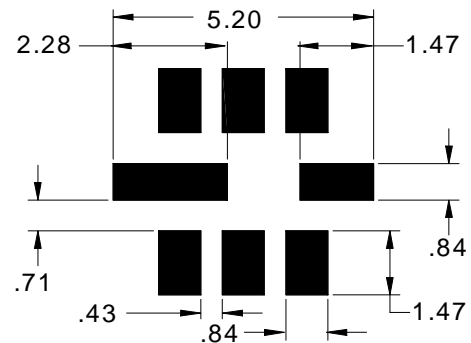
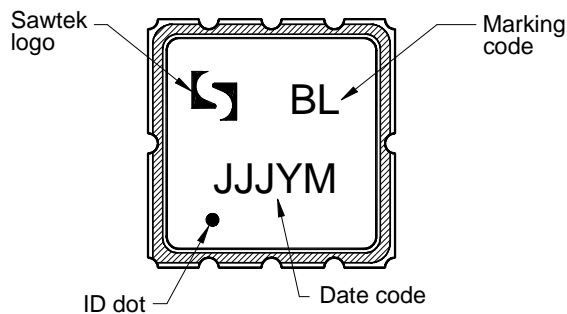

The date code consists of: day of the current year (Julian, 3 digits), last digit of the year (1 digit) and hour (2 digits)

This footprint represents a recommendation only  
Dimensions shown are nominal in millimeters

**Tape and Reel**

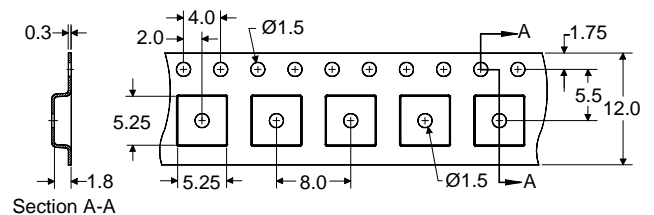
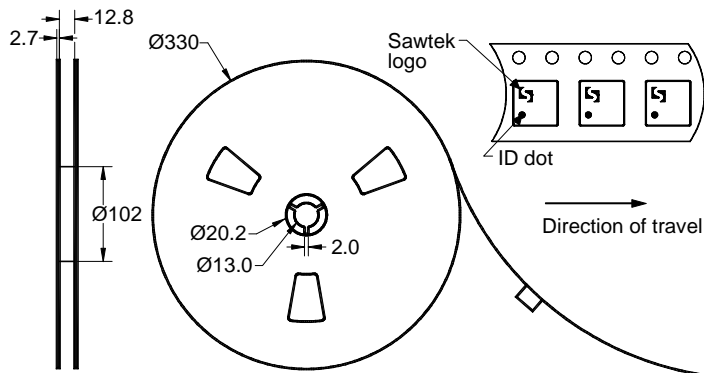

Dimensions shown are nominal in millimeters  
Packaging quantity: 4000 units/reel

### Maximum Ratings

Parameter	Symbol	Minimum	Maximum	Unit
Operating Temperature Range	T	-40	+85	°C
Storage Temperature Range	T <sub>stg</sub>	-40	+85	°C

### Important Notes

#### Warnings

- Electrostatic Sensitive Device (ESD) 
- Avoid ultrasonic exposure

#### RoHS Compliance

- This product complies with EU directive 2002/95/EC (RoHS) 

#### Solderability

- Compatible with JESD22-B102, Pb-free process, 260C peak reflow temperature ([see soldering profile](#))

### Links to Additional Technical Information

[PCB Layout Tips](#)

[Qualification Flowchart](#)

[Soldering Profile](#)

[S-Parameters](#)

[RoHS Information](#)

[Other Technical Information](#)

TriQuint's liability is limited only to the Surface Acoustic Wave (SAW) component(s) described in this data sheet. TriQuint does not accept any liability for applications, processes, circuits or assemblies, which are implemented using any TriQuint component described in this data sheet.

### Contact Information

**TriQuint**   
SEMICONDUCTOR

PO Box 609501  
Orlando, FL 32860-9501  
USA

Phone: +1 (407) 886-8860  
Fax: +1 (407) 886-7061  
Email: [info-product@tqs.com](mailto:info-product@tqs.com)  
Web: [www.triquint.com](http://www.triquint.com)

Or contact one of our worldwide  
Network of [sales offices](#),  
[Representatives or distributors](#)