

Features

- For multiple applications
- Usable bandwidth 20 MHz
- Low loss
- High attenuation
- Balanced operation
- Ceramic Surface Mount Package (SMP)
- Hermetic
- RoHS compliant (2002/95/EC), Pb-free 

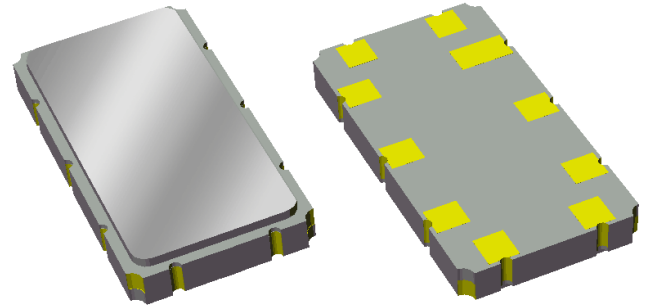

Package

Surface Mount 9.10 x 4.80 x 1.24 mm
SMP-35C

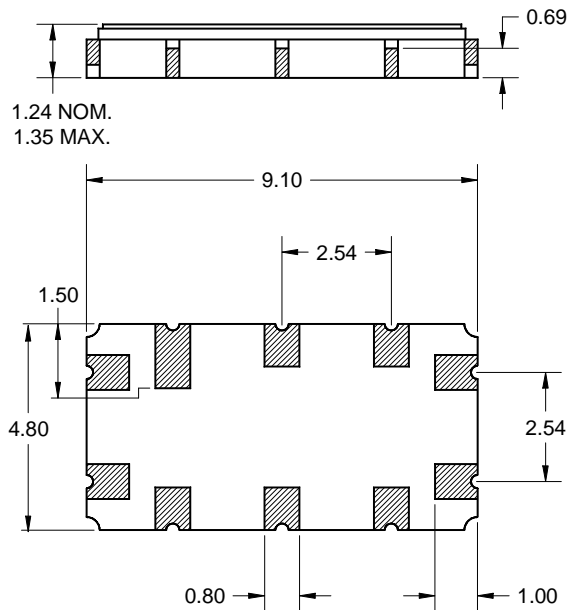

Dimensions shown are nominal in millimeters
All tolerances are ± 0.15 mm except overall
length and width ± 0.10 mm

Body: Al_2O_3 ceramic
Lid: Kovar, Ni plated
Terminations: Au plating 0.5 - 1.0 μ m,
over a 2 - 6 μ m Ni plating

Pin Configuration

Bottom View

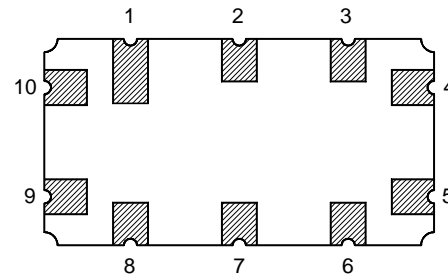

Pin No.	Description
9	Input +
10	Input -
4	Output +
5	Output -
1,2,3,6,7,8	Case Ground

Electrical Specifications ⁽¹⁾

Operating Temperature Range: ⁽²⁾ -40 to +85 °C

Parameter ⁽³⁾	Minimum	Typical ⁽⁵⁾	Maximum	Unit
Center Frequency	-	140	-	MHz
Minimum Insertion Loss	-	9.8	13	dB
Amplitude Variation 130 – 150 MHz	-	0.4	1.0	dB p-p
Phase Linearity 131 – 149 MHz	-	2.5	6	° p-p
130 – 150 MHz	-	2.5	6	° p-p
Average Group Delay 130 – 150 MHz	0.66	0.71	0.76	µs
Relative Attenuation ⁽⁴⁾				
10 – 100 MHz	40	66	-	dB
100 – 108 MHz	38	55	-	dB
108 – 116 MHz	33	52	-	dB
116 – 121.5 MHz	22	43	-	dB
158.5 – 164 MHz	22	40	-	dB
164 – 172 MHz	33	50	-	dB
172 – 187 MHz	40	51	-	dB
187 – 192 MHz	38	54	-	dB
192 – 248 MHz	40	47	-	dB
248 – 265 MHz	36	42	-	dB
265 – 350 MHz	40	46	-	dB
Triple Transit Suppression	30	52	-	dB
Source Impedance (balanced) ⁽⁶⁾	-	50	-	Ω
Load Impedance (balanced) ⁽⁶⁾	-	50	-	Ω

Notes:

1. All specifications are based on the TriQuint matching schematic shown on page 5
2. In production, devices will be tested at room temperature to a guardbanded specification to ensure electrical compliance over temperature
3. Electrical margin has been built into the design to account for the variations due to temperature drift and manufacturing tolerances
4. Relative to minimum insertion loss
5. Typical values are based on average measurements at room temperature
6. This is the optimum impedance in order to achieve the performance shown

Electrical Specifications ⁽¹⁾

Operating Temperature Range: ⁽²⁾ -20 to +85 °C

Parameter ⁽³⁾	Minimum	Typical ⁽⁵⁾	Maximum	Unit
Center Frequency	-	140	-	MHz
Minimum Insertion Loss	-	9.8	13	dB
Amplitude Variation 130 – 150 MHz	-	0.4	1.0	dB p-p
Phase Linearity 131 – 149 MHz	-	2.5	5.65	° p-p
130 – 150 MHz	-	2.5	5.50	° p-p
Average Delay 130 – 150 MHz	0.66	0.71	0.76	µs
Relative Attenuation ⁽⁴⁾				
10 – 100 MHz	40	66	-	dB
100 – 108 MHz	38	55	-	dB
108 – 116 MHz	33	52	-	dB
116 – 121.5 MHz	22	43	-	dB
158.5 – 164 MHz	22	40	-	dB
164 – 172 MHz	33	50	-	dB
172 – 187 MHz	40	51	-	dB
187 – 192 MHz	38	54	-	dB
192 – 248 MHz	40	47	-	dB
248 – 265 MHz	36	42	-	dB
265 – 350 MHz	40	46	-	dB
Triple Transit Suppression	30	52	-	dB
Source Impedance (balanced) ⁽⁶⁾	-	50	-	Ω
Load Impedance (balanced) ⁽⁶⁾	-	50	-	Ω

Notes:

1. All specifications are based on the TriQuint matching schematic shown on page 5
2. In production, devices will be tested at room temperature to a guardbanded specification to ensure electrical compliance over temperature
3. Electrical margin has been built into the design to account for the variations due to temperature drift and manufacturing tolerances
4. Relative to minimum insertion loss
5. Typical values are based on average measurements at room temperature
6. This is the optimum impedance in order to achieve the performance shown

Typical Performance (at room temperature)

Frequency Response

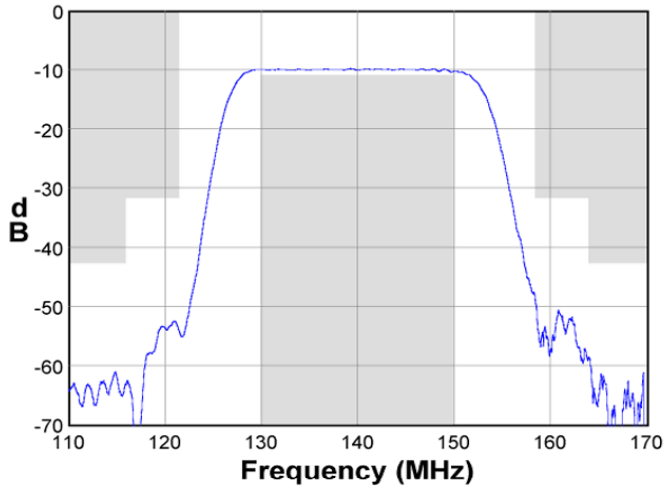

Passband Response

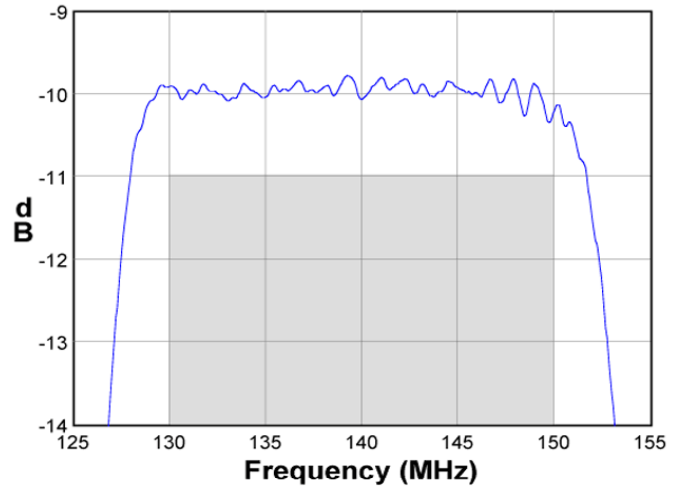

Wideband Response

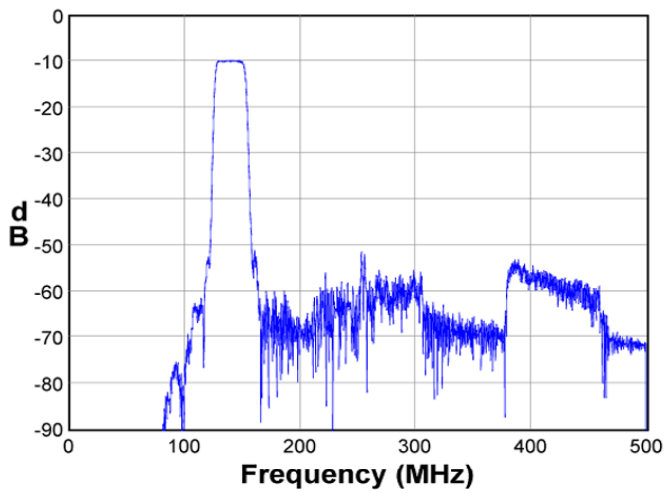

Phase / Group Delay

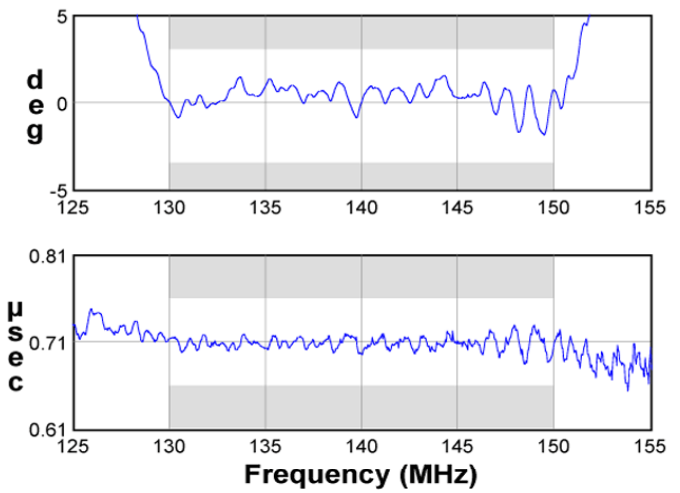

Input Smith Chart

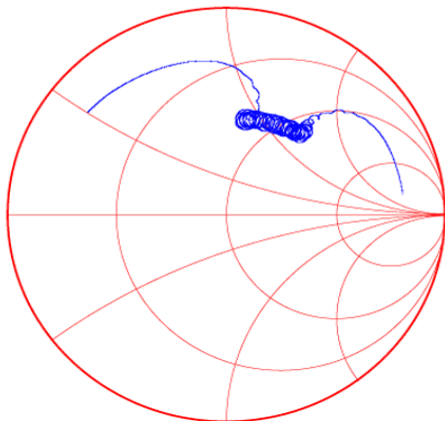

Output Smith Chart

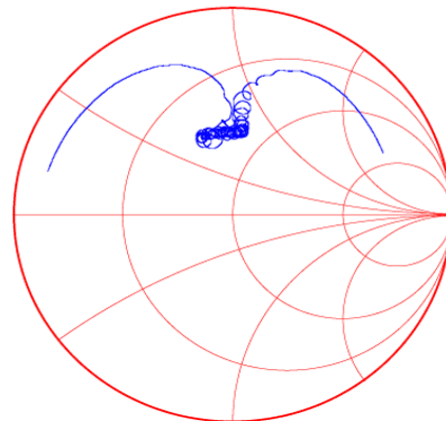

Matching Schematic

Actual matching values may vary due to PCB layout and parasitics

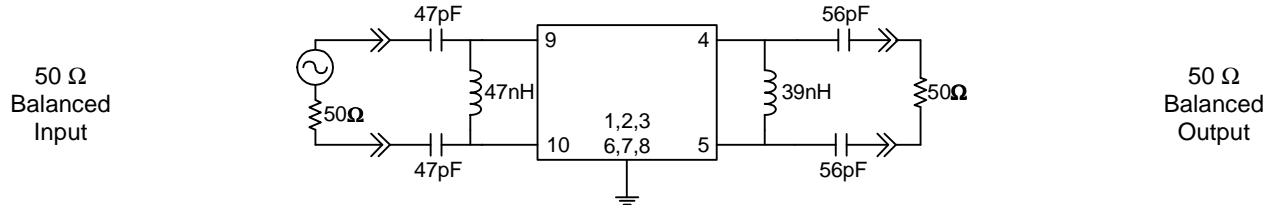

Marking

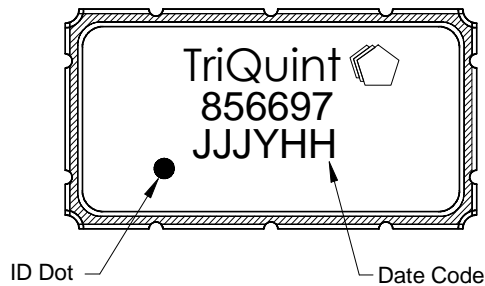

The date code consists of: day of the current year (Julian, 3 digits), last digit of the year (1 digit) and hour (2 digits)

PCB Footprint

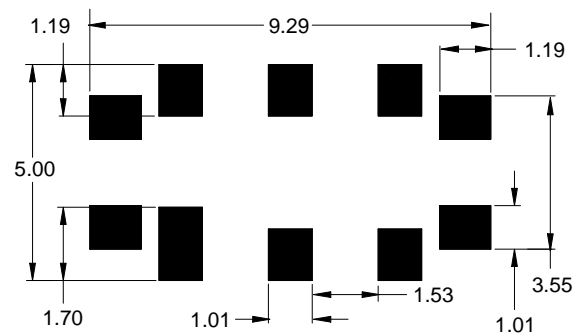

This footprint represents a recommendation only
Dimensions shown are nominal in millimeters

Tape and Reel

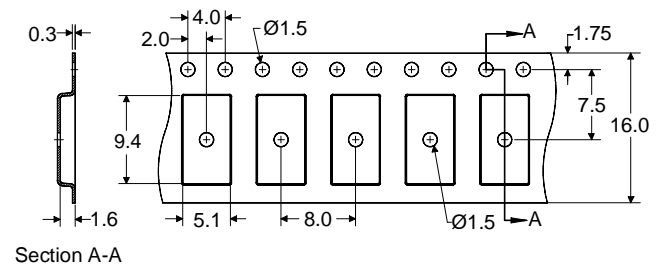
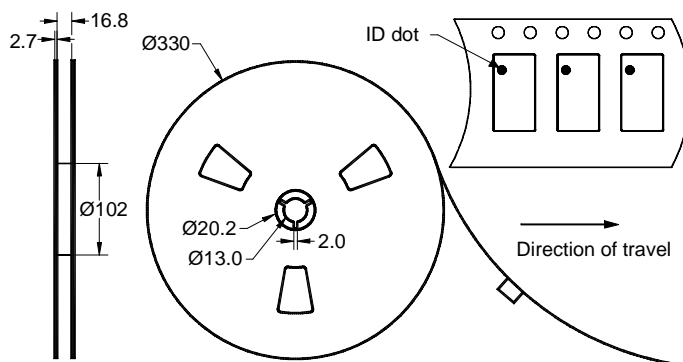

Dimensions shown are nominal in millimeters
Packaging quantity: 4000 units/reel

Maximum Ratings

Parameter	Symbol	Minimum	Maximum	Unit
Operating Temperature Range	T	-40	+85	°C
Storage Temperature Range	T _{stg}	-55	+125	°C
Pyroelectric Voltage	V _{Pyro}	-	50	mV p-p
Input Power	P _{in}	-	+20	dBm

Important Notes

Warnings

- Electrostatic Sensitive Device (ESD) 
- Avoid ultrasonic exposure

RoHS Compliance

- This product complies with EU directive 2002/95/EC (RoHS) 

Solderability

- Compatible with JEDEC J-STD-020C **Pb-free** process, **260°C** peak reflow temperature ([see soldering profile](#))

Links to Additional Technical Information

[PCB Layout Tips](#)

[Qualification Flowchart](#)

[Soldering Profile](#)

[S-Parameters](#)

[RoHS Information](#)

[Other Technical Information](#)

TriQuint's liability is limited only to the Surface Acoustic Wave (SAW) component(s) described in this data sheet. TriQuint does not accept any liability for applications, processes, circuits or assemblies, which are implemented using any TriQuint component described in this data sheet.

Contact Information

TriQuint 
SEMICONDUCTOR
PO Box 609501
Orlando, FL 32860-9501
USA

Phone: +1 (407) 886-8860
Fax: +1 (407) 886-7061
Email: info-product@tqs.com
Web: www.triquint.com

Or contact one of our worldwide
Network of [sales offices](#),
[Representatives or distributors](#)