

Features

- For Base Station applications
- Usable bandwidth of 60 MHz
- Low loss
- High Attenuation
- No impedance matching required for operation at 50 Ω
- Single-ended operation
- Ceramic Surface Mount Package (SMP)
- Hermetic
- RoHS compliant (2002/95/EC), Pb-free 

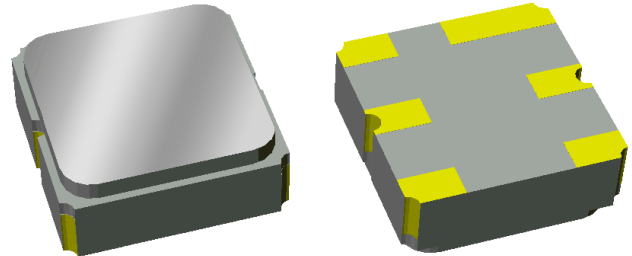

Package

Surface Mount 3.00 x 3.00 x 1.22 mm
SMP-12

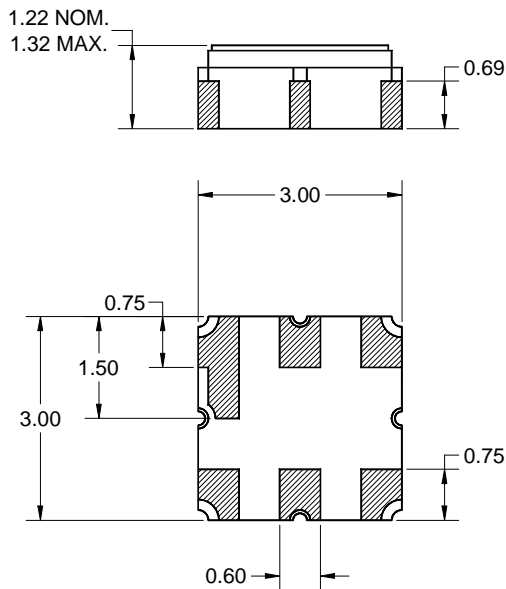

Pin Configuration

Bottom View

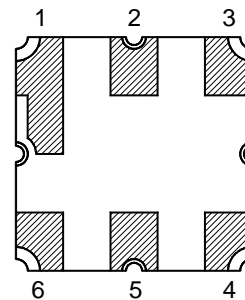

Pin No.	Description
2	Input
5	Output
1,3,4,6	Case ground

Dimensions shown are nominal in millimeters
All tolerances are ± 0.15 mm except overall
length and width ± 0.10 mm

Body: Al_2O_3 ceramic
Lid: Kovar, Ni plated
Terminations: Au plating 0.5 - 1.0 μ m,
over a 2 - 6 μ m Ni plating

Electrical Specifications ⁽¹⁾

Operating Temperature Range: ⁽²⁾ -30 to +85 °C

Parameter ⁽³⁾	Minimum	Typical ⁽⁴⁾	Maximum	Unit
Center Frequency	-	1880	-	MHz
Maximum Insertion Loss 1850 – 1910 MHz	-	2.2	2.75	dB
Amplitude Variation ⁽⁵⁾ 1850 – 1910 MHz	-	0.74	1.6	dB p-p
Amplitude Variation (over any 5MHz band) ⁽⁵⁾ 1850 – 1910 MHz	-	0.72	0.8	dB p-p
Stopband Rejection ⁽⁶⁾				
180 – 220 MHz	25	48	-	dB
940 – 1430 MHz	25	36	-	dB
1430 – 1498 MHz	35	39	-	dB
1498 – 1742 MHz	25	35	-	dB
1742 – 1806 MHz	15	22	-	dB
2199 – 2660 MHz	25	32	-	dB
3073 – 3615 MHz	20	33	-	dB
4715 – 5317 MHz	7	24	-	dB
6356 – 7019 MHz	2	14	-	dB
Input/Output VSWR 1850 – 1910 MHz	-	1.53	2.0	-
Phase Ripple 1850 – 1910 MHz	-	-	20	deg p-p
Group Delay Ripple 1850 – 1910 MHz	-	-	25	ns p-p
Absolute Delay 1850 – 1910 MHz	-	-	30	ns
Source Impedance: ⁽⁷⁾	-	50	-	Ω
Load Impedance: ⁽⁷⁾	-	50	-	Ω

Notes:

1. All specifications are based on the TriQuint test circuit shown on page 4
2. In production, devices will be tested at room temperature to a guardbanded specification to ensure electrical compliance over temperature
3. Electrical margin has been built into the design to account for the variations due to temperature drift and manufacturing tolerances
4. Typical values are based on average measurements at room temperature
5. Describes the total variation over the defined frequency range
6. Stop Band attenuation is relative to maximum insertion loss
7. This is the optimum impedance in order to achieve the performance shown

Typical Performance (at room temperature)

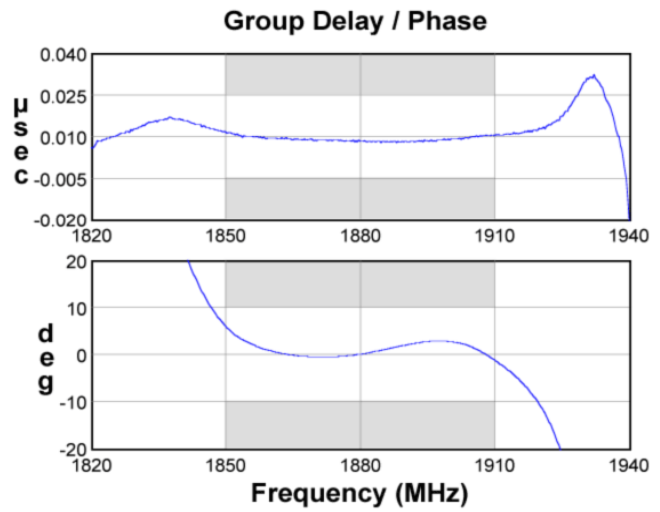
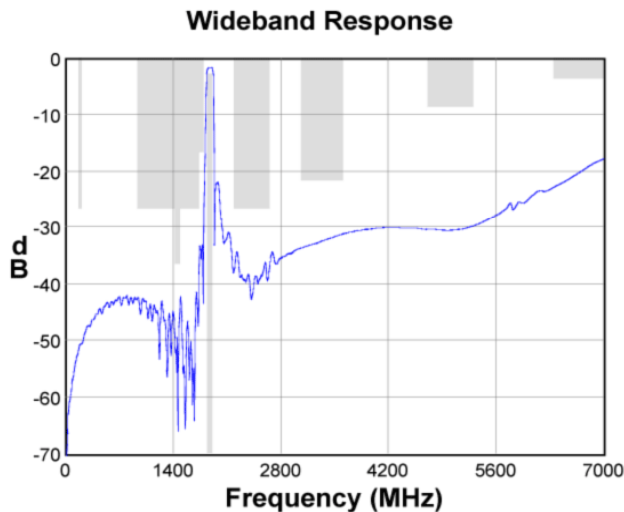
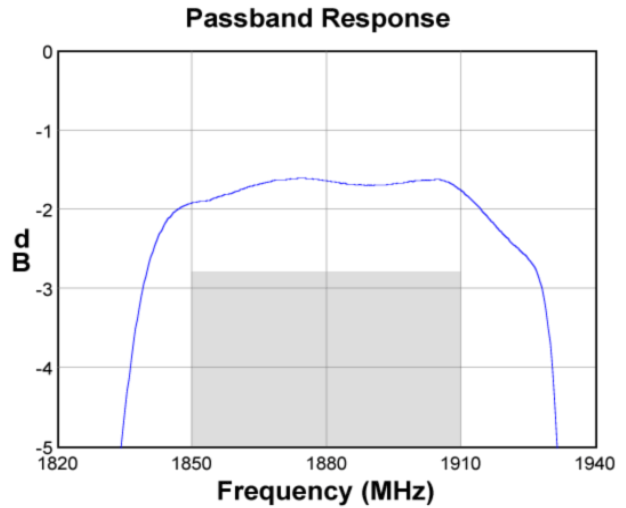
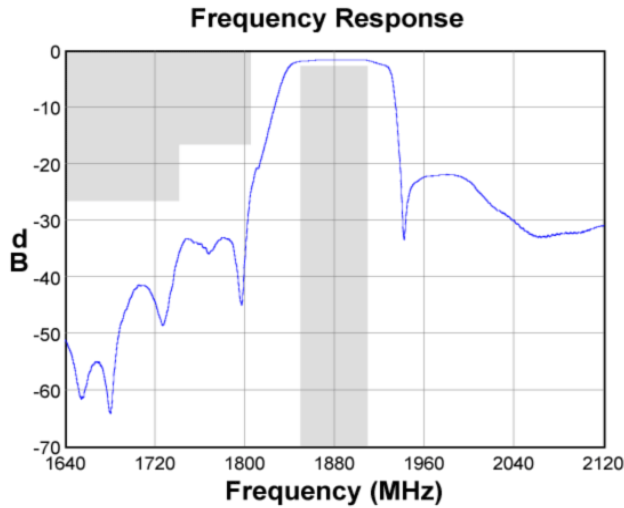

Input Smith Chart

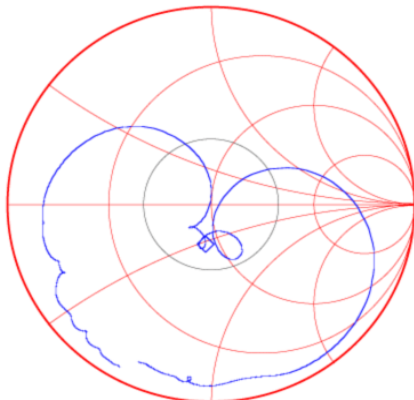

Output Smith Chart

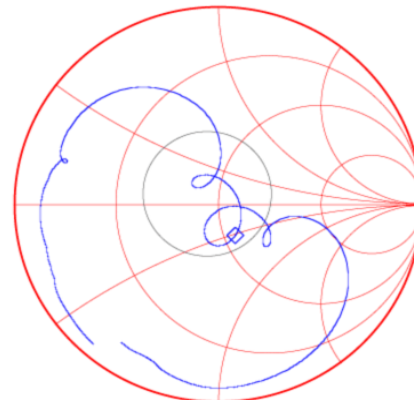

Matching Schematics

Actual matching values may vary due to PCB layout and parasitics

50 Ω
Single-ended
Input

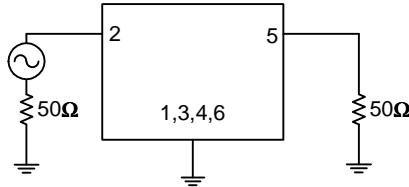

50 Ω
Single-ended
Output

Marking

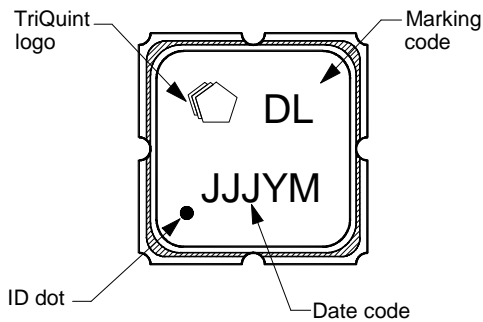

The date code consists of: day of the current year (Julian, 3 digits), Y = last digit of the year and M = manufacturing site code

PCB Footprint

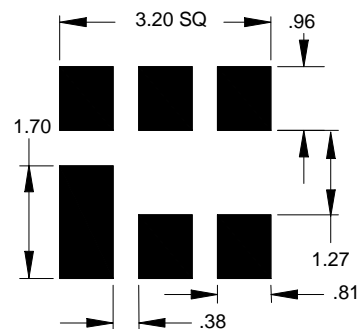

This footprint represents a recommendation only
Dimensions shown are nominal in millimeters

Tape and Reel

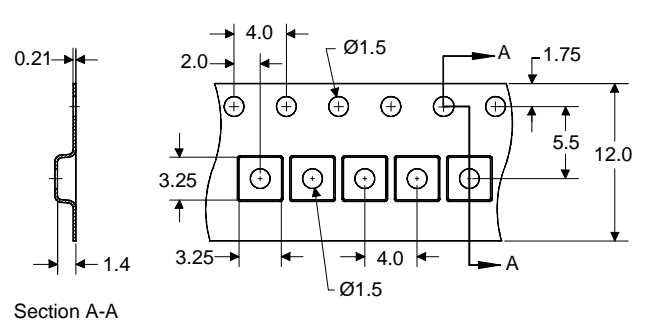
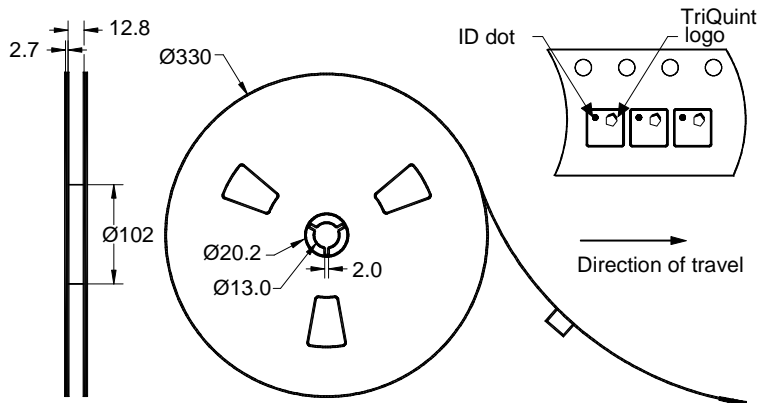

Dimensions shown are nominal in millimeters
Packaging quantity: 5000 units/reel

Maximum Ratings

Parameter	Symbol	Minimum	Maximum	Unit
Operating Temperature Range	T	-30	+85	°C
Storage Temperature Range	T _{stg}	-40	+85	°C
DC voltage on any port (instantaneous only)	-	-	+5	V
Input Power	P _{in}	-	+22	dBm

Notes:

1. Input Power is targeted for an applied CW modulated RF signal at 55 °C for 125 hours

Important Notes

Warnings

- Electrostatic Sensitive Device (ESD) 
- Avoid ultrasonic exposure

RoHS Compliance

- This product complies with EU directive 2002/95/EC (RoHS) 

Solderability

- Compatible with JESD22-B102, Pb-free process, 260C peak reflow temperature ([see soldering profile](#))

Links to Additional Technical Information

[PCB Layout Tips](#)

[Qualification Flowchart](#)

[Soldering Profile](#)

[S-Parameters](#)

[RoHS Information](#)

[Other Technical Information](#)

TriQuint's liability is limited only to the Surface Acoustic Wave (SAW) component(s) described in this data sheet. TriQuint does not accept any liability for applications, processes, circuits or assemblies, which are implemented using any TriQuint component described in this data sheet.

Contact Information

TriQuint 
SEMICONDUCTOR

PO Box 609501
Orlando, FL 32860-9501
USA

Phone: +1 (407) 886-8860
Fax: +1 (407) 886-7061
Email: info-product@tqs.com
Web: www.triquint.com

Or contact one of our worldwide
Network of [sales offices](#),
[Representatives or distributors](#)