

Features

- For WCDMA applications
- Usable bandwidth 30 MHz
- Low loss
- Single-ended operation
- Ceramic Surface Mount Package (SMP)
- Small Size
- Hermetic
- RoHS compliant (2002/95/EC), Pb-free 

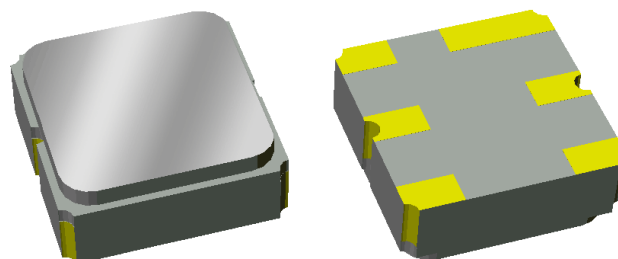

Pin Configuration

Surface Mount 3.00 x 3.00 x 1.22 mm
SMP-12

Bottom View

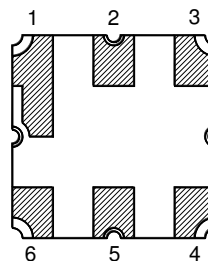
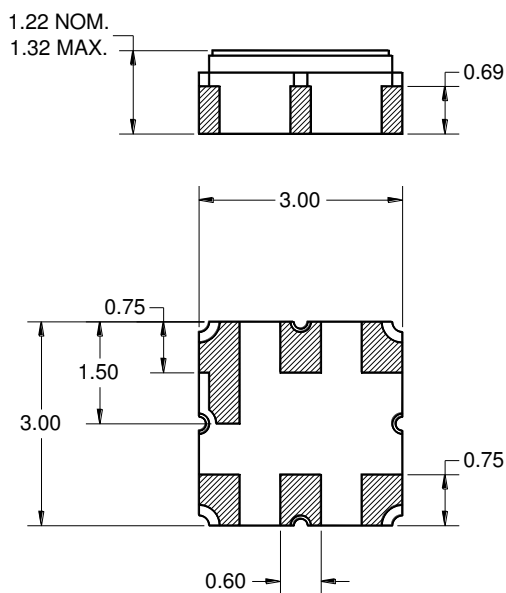

Pin No.	Description
2	Input
5	Output
1,3,4,6	Case ground

Dimensions shown are nominal in millimeters
All tolerances are ± 0.15 mm except overall
length and width ± 0.10 mm

Body: Al_2O_3 ceramic
Lid: Kovar, Ni plated
Terminations: Au plating 0.5 - 1.0 μ m,
over a 2 - 6 μ m Ni plating

Electrical Specifications ⁽¹⁾⁽²⁾

Operated Temperature Range: ⁽³⁾ -30 to +85 °C

Parameter ⁽⁴⁾	Minimum	Typical ⁽⁵⁾	Maximum	Unit
Center Frequency	-	847	-	MHz
Maximum Insertion Loss 832 – 862 MHz	-	1.3	2.0	dB
Amplitude Variation 832 – 862 MHz	-	0.29	1.2	dB p-p
Amplitude Variation (over any 5 MHz window) 832 – 862 MHz	-	0.21	0.8	dB p-p
Input/Output VSWR 832 – 862 MHz	-	1.63	2.0	-
Phase Ripple 832 – 862 MHz	-	10.5	30	deg
Absolute Delay 832 – 862 MHz	-	18.2	30	ns
Group Delay Variation 832 – 862 MHz	-	12	20	ns p-p
Relative Attenuation ⁽⁶⁾				
60 – 120 MHz	30	47.7	-	dB
300 – 500 MHz	30	39.6	-	dB
645 – 680 MHz	30	37.7	-	dB
782 – 812 MHz	10	24.5	-	dB
812 – 816 MHz	10	19.0	-	dB
882 – 912 MHz	10	16.5	-	dB
1010 – 1100 MHz	25	33.7	-	dB
1545 – 1580 MHz	45	49.6	-	dB
2000 – 2800 MHz	25	31.0	-	dB
3200 – 4000 MHz	15	27.3	-	dB
4400 – 5250 MHz	5	12.0	-	dB
Source Impedance (single-ended) ⁽⁷⁾	-	50	-	Ω
Load Impedance (single-ended) ⁽⁷⁾	-	50	-	Ω

Notes:

1. All target specifications are based on TriQuint test circuit shown below
2. All target specifications represent a design goal and not a guarantee until the design is finalized and a datasheet is issued
3. In production, devices will be tested at room temperature to a guardbanded specification to ensure electrical compliance over temperature
4. Electrical margin has been built into the design to account for the variations due to temperature drift and manufacturing tolerances
5. Typical values are based on average measurements at room temperature
6. Attenuation relative to Max Loss over Passband
7. This is the optimum impedance In order to achieve the performance shown

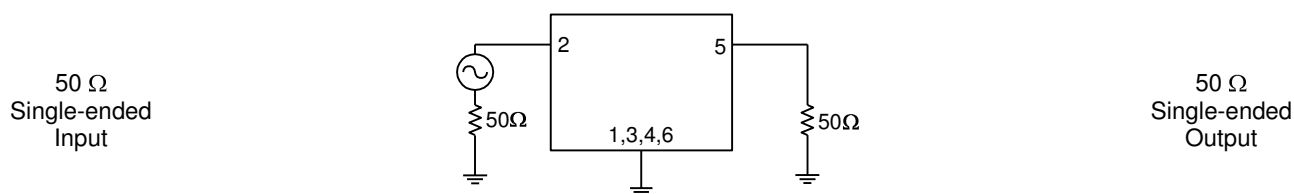

Typical Performance (at +25°C)

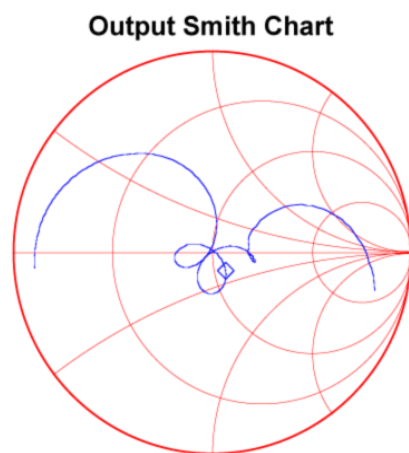
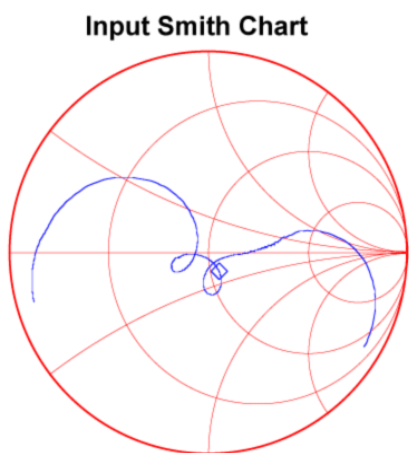
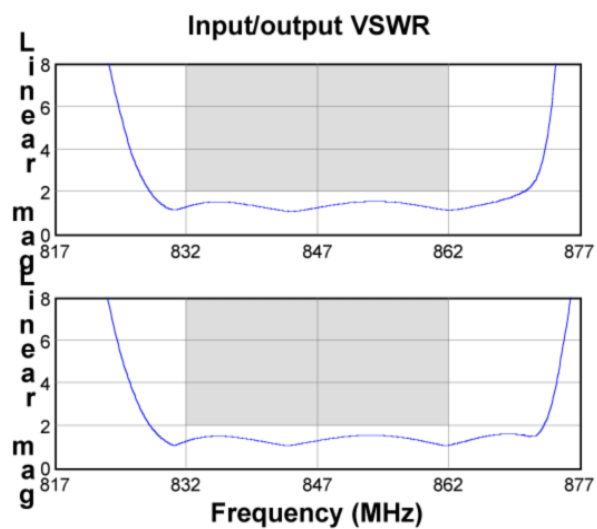
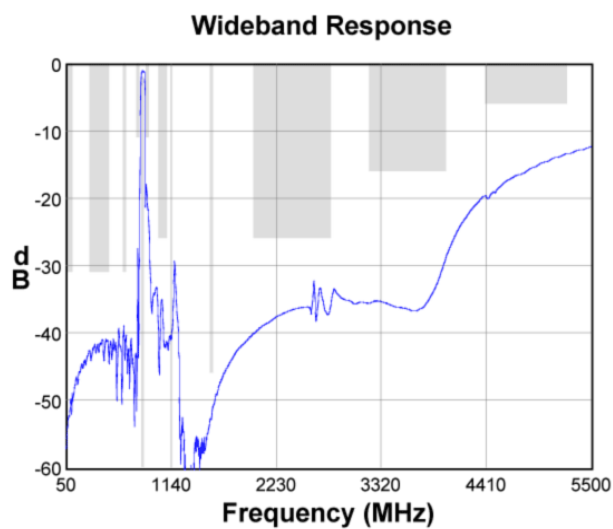
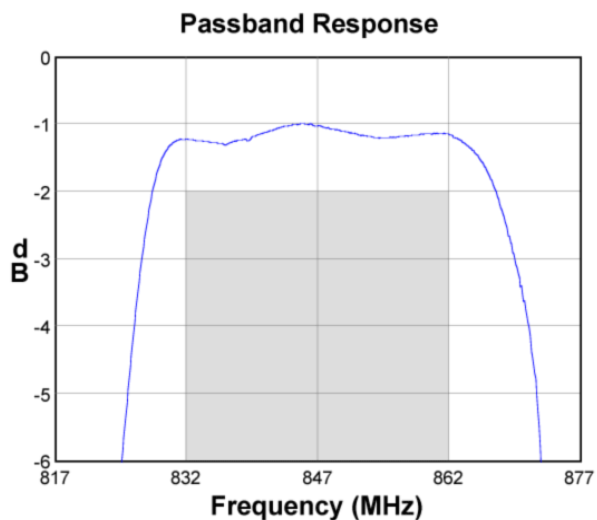
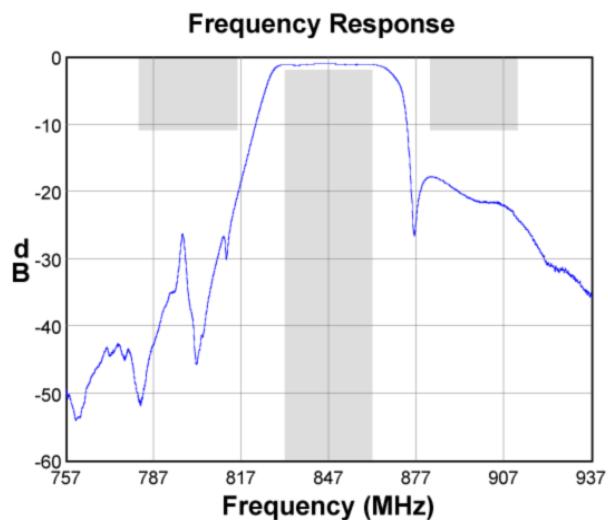

Matching Schematics

Actual matching values may vary due to PCB layout and parasitics

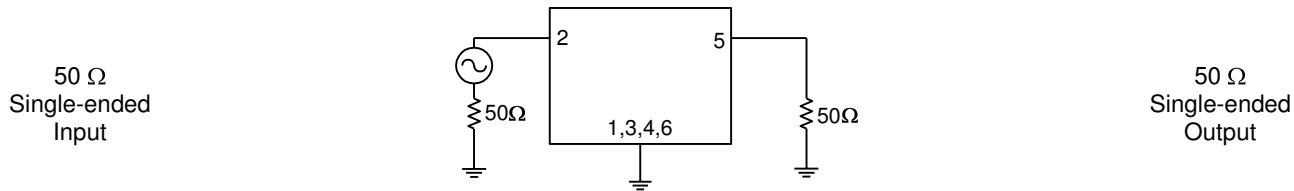

Marking

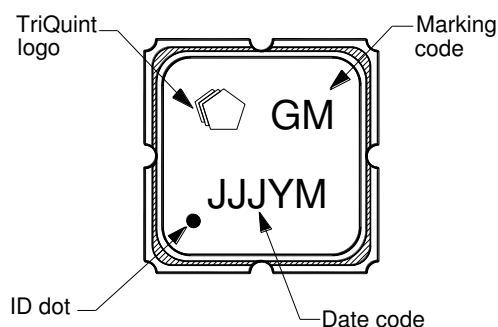

The date code consists of: day of the current year (Julian, 3 digits), Y = last digit of the year and M = manufacturing site code

PCB Footprint

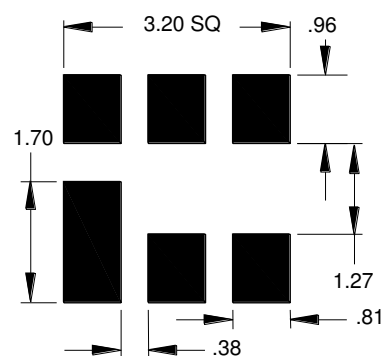

This footprint represents a recommendation only
Dimensions shown are nominal in millimeters

Tape and Reel

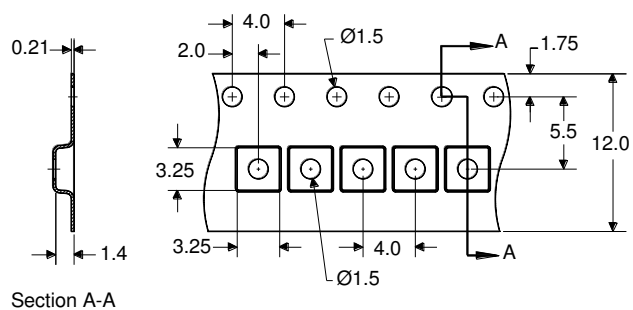
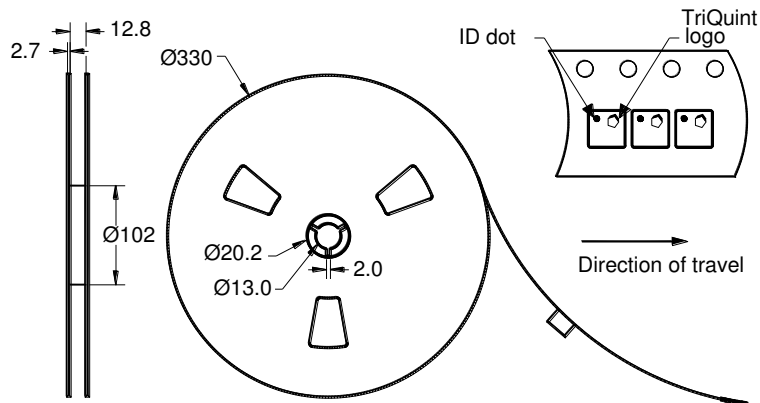

Dimensions shown are nominal in millimeters
Packaging quantity: 5000 units/reel

Maximum Ratings

Parameter	Symbol	Minimum	Maximum	Unit
Operating Temperature Range	T	-30	+85	°C
Storage Temperature Range	T _{stg}	-40	+85	°C
Input Power ⁽¹⁾	P _{in}	-	+22	dBm

Note:

1. Input Power is targeted for an applied CW modulated RF signal at 55 °C for 125 hours

Important Notes

Warnings

- Electrostatic Sensitive Device (ESD) 
- Avoid ultrasonic exposure

RoHS Compliance

- This product complies with EU directive 2002/95/EC (RoHS) 

Solderability

- Compatible with JEDEC J-STD-020C **Pb**-free process, **260 °C** peak reflow temperature

Links to Additional Technical Information

[PCB Layout Tips](#)

[Qualification Flowchart](#)

[Soldering Profile](#)

[S-Parameters](#)

[RoHS Information](#)

[Other Technical Information](#)

TriQuint's liability is limited only to the Surface Acoustic Wave (SAW) component(s) described in this data sheet. TriQuint does not accept any liability for applications, processes, circuits or assemblies, which are implemented using any TriQuint component described in this data sheet.

Contact Information



PO Box 609501
Orlando, FL 32860-9501
USA

Phone: +1 (407) 886-8860
Fax: +1 (407) 886-7061
Email: info-product@tqs.com
Web: www.triquint.com

Or contact one of our worldwide
Network of [sales offices](#),
[Representatives or distributors](#)