

856934

1842.5 MHz SAW Filter

Applications

- General purpose wireless
- Wireless infrastructure
- 3G, 4G, Multi-standard
- Repeaters

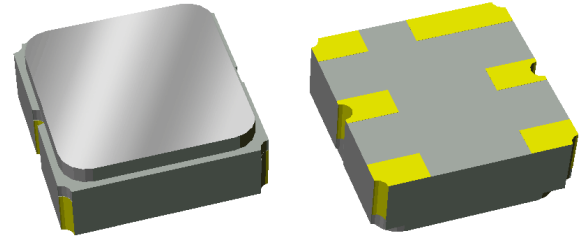

Product Features

- Usable bandwidth 75 MHz
- Low loss
- Excellent power handling
- Single-ended operation
- Ceramic Surface Mount Package (SMP)
- No impedance matching required for operation at 50Ω
- Small Size: 3.00 x 3.00 x 1.22 mm
- Hermetically sealed
- **RoHS** compliant, **Pb**-free

General Description

856934 is a general purpose Downlink filter for band 3. This filter was specifically designed in a 3x3mm hermetic package for base station applications and is part of our wide portfolio of RF filters in the same package.

Low insertion loss, coupled with high attenuation and excellent power handling, makes this filter a natural choice for our customers' Downlink RF filtering needs.

Functional Block Diagram

Top view

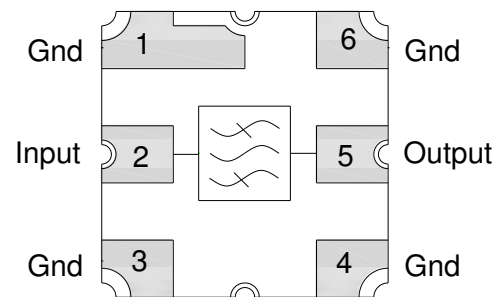

Pin Configuration

Pin # SE	Description
2	Input
5	Output
1,3,4,6	Case Ground

Ordering Information

Part No.	Description
856934	packaged part
960700-EVB	evaluation board

Standard T/R size = 5000 units/reel.

Specifications

Electrical Specifications ⁽¹⁾

Specified Temperature Range: ⁽²⁾ -10 to +85 °C

Parameter ⁽³⁾	Conditions	Min	Typical ⁽⁴⁾	Max	Units
Center Frequency		-	1842.5	-	MHz
Maximum Insertion Loss ⁽⁵⁾	1805 – 1880 MHz	-	2.9	4.2	dB
Amplitude Variation ⁽⁶⁾	1805 – 1880 MHz	-	1.4	2.8	dB p-p
Attenuation ⁽⁵⁾	10 – 370 MHz	40	44	-	dB
	370 – 1300 MHz	37	40	-	dB
	1300 – 1705 MHz	30	35	-	dB
	1705 – 1785 MHz	20	25	-	dB
	1920 – 1980 MHz	18	20	-	dB
	1980 – 2530MHz	20	24	-	dB
	2530 – 2680 MHz	20	30	-	dB
	2680 – 3400 MHz	20	29	-	dB
	3400 – 3975 MHz	24	27	-	dB
	3975 – 4200 MHz	20	27	-	dB
	4200 – 4920MHz	5	20	-	dB
4920 – 5200 MHz	5	13	-	dB	
5200– 6000 MHz	4	6.5	-	dB	
Input VSWR ⁽⁷⁾	1805 – 1880 MHz	-	2.2	2.6	-
Output VSWR ⁽⁷⁾	1805 – 1880 MHz	-	2.2	2.4	-
Source Impedance (single-ended) ⁽⁸⁾		-	50	-	Ω
Load Impedance (single-ended) ⁽⁸⁾		-	50	-	Ω

Notes:

- All specifications are based on the TriQuint schematic for the main reference design shown on page 3
- In production, devices will be tested at room temperature to a guardbanded specification to ensure electrical compliance over temperature
- Electrical margin has been built into the design to account for the variations due to temperature drift and manufacturing tolerances
- Typical values are based on average measurements at room temperature
- Relative to zero dB
- Amplitude Variation includes roll off at the bandedges
- VSWR unmatched (adding additional matching components can improve this parameter)
- This is the optimum impedance in order to achieve the performance shown

Absolute Maximum Ratings

Parameter	Rating
Operating Temperature	-10 to +85 °C
Storage Temperature	-40 to +85 °C
Input Power ⁽⁹⁾	+9 dBm

- Input power is tested with an applied continuous wave RF signal for an expected lifetime of 10,000 hours at 55 °C

Operation of this device outside the parameter ranges given above may cause permanent damage.

Reference Design 1 – 50Ω SE Input, 50Ω SE Output

Schematic

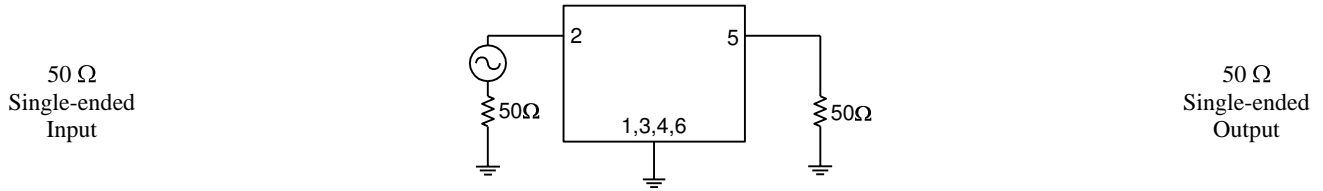

Notes:

1. No impedance matching required
2. Actual matching values may vary due to PCB layout and parasitic

PC Board

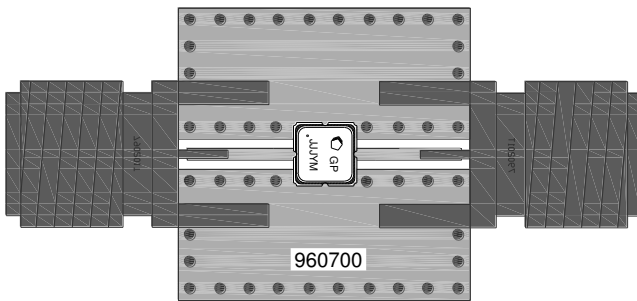

Mounting Configuration

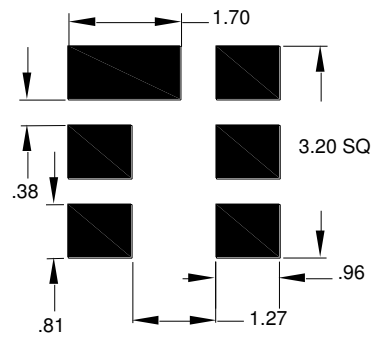

Notes:

- Top, middle & bottom layers: 1/2 oz copper
- Substrates: FR4 dielectric .063” / Taconic TLY-5A .0075”
- Finish plating: Nickel: 3-8μm thick, Gold: .03-.2μm thick
- Hole plating: Copper min .0008μm

Notes:

1. All dimensions are in millimeters.
2. This footprint represents a recommendation only.

Bill of Material

Reference Desg.	Value	Description	Manufacturer	Part Number
SMA	N/A	SMA connector	Radiall USA Inc.	9602-1111-018
PCB	N/A	3-layer	multiple	960700

Typical Performance (at room temperature)

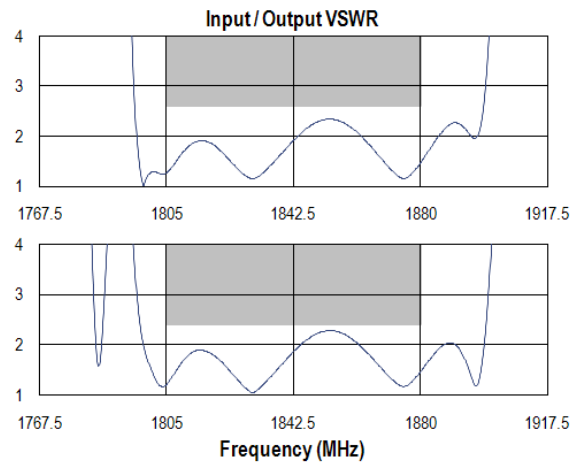
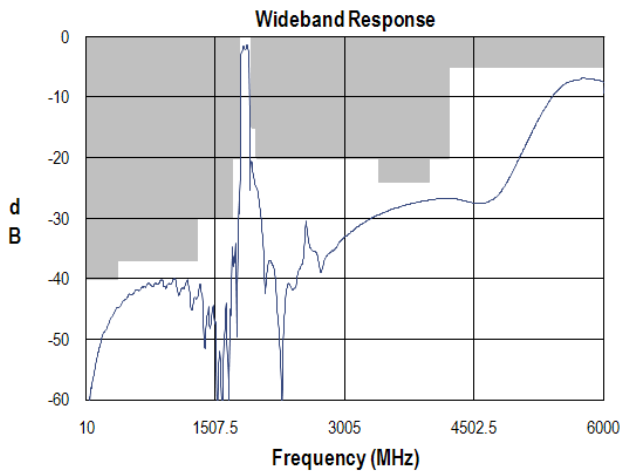
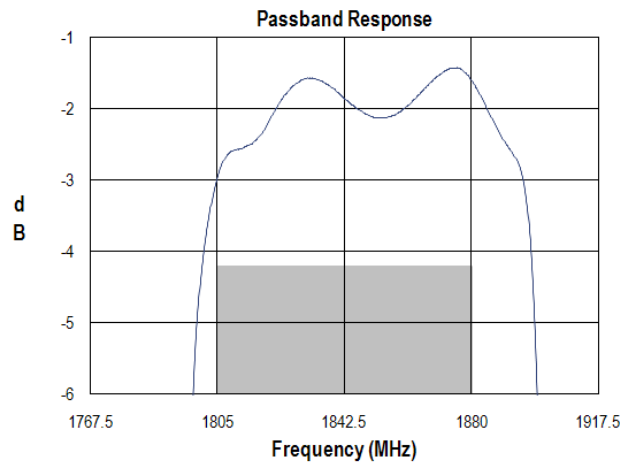
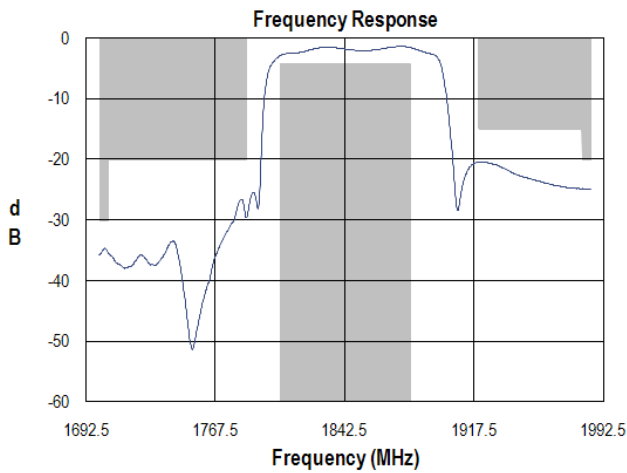

Input Smith Chart

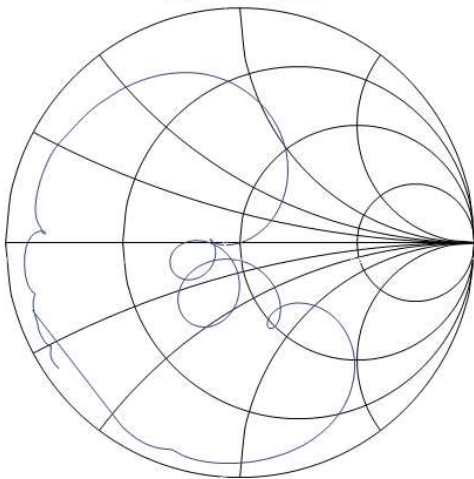

Output Smith Chart

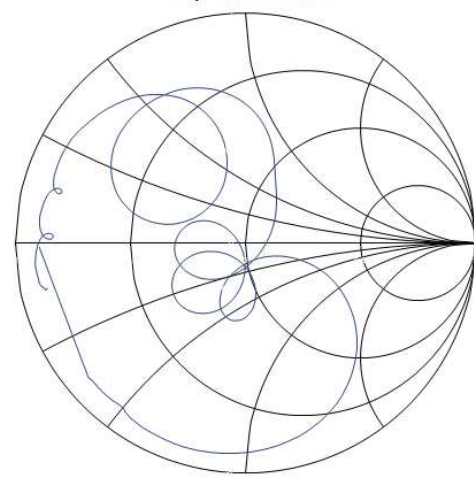

Mechanical Information

Package Information, Dimensions and Marking

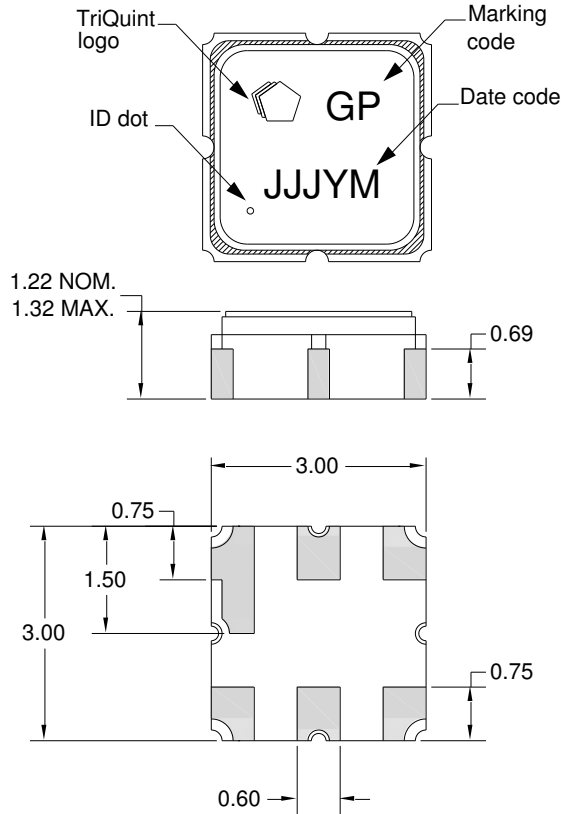

Package Style: SMP-12A
 Dimensions: 3.00 x 3.00 x 1.22 mm

Body: Al₂O₃ ceramic
 Lid: Kovar, Ni plated
 Terminations: Au plating 0.5 - 1.0µm, over a 2-6µm Ni plating

All dimensions shown are nominal in millimeters
 All tolerances are ±0.15mm except overall length and width ±0.10mm

The date code consists of day of the current year (Julian, 3 digits), Y = last digit of the year, and M = manufacturing site code

Tape and Reel Information

Standard T/R size = 5000 units/reel. All dimensions are in millimeters

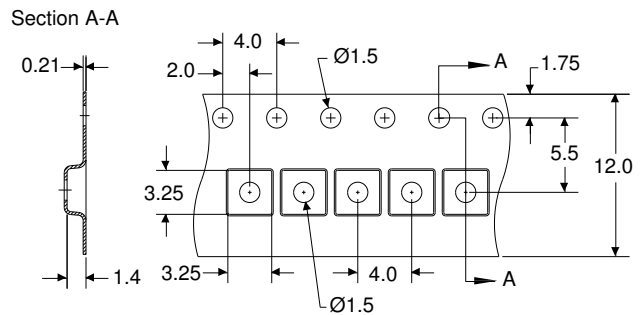
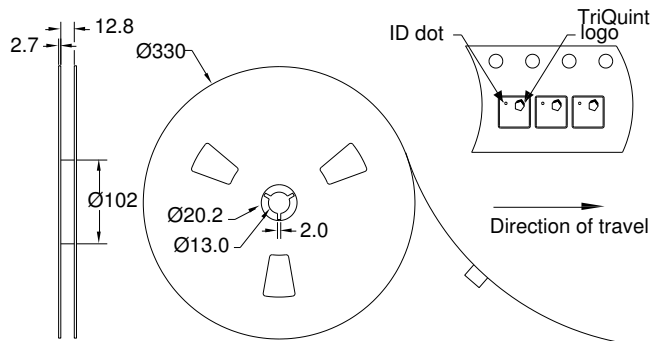

Product Compliance Information

ESD Information



Caution! ESD-Sensitive Device

ESD Rating: 0

Value: Passes ≥ 200 V min.
Test: Human Body Model (HBM)
Standard: JEDEC Standard JESD22-A114

ESD Rating: A

Value: Passes ≥ 100 V min.
Test: Machine Model (MM)
Standard: JEDEC Standard JESD22-A115

MSL Rating

Devices are Hermetic, therefore MSL is not applicable

Solderability

Compatible with the latest version of J-STD-020, lead free solder, 260°C

Refer to [Soldering Profile](#) for recommended guidelines.

This part is compliant with EU 2002/95/EC RoHS directive (Restrictions on the Use of Certain Hazardous Substances in Electrical and Electronic Equipment).

This product also has the following attributes:

- Halogen Free (Chlorine, Bromine)
- Antimony Free
- TBBP-A (C₁₅H₁₂Br₄O₂) Free
- PFOS Free
- SVHC Free

Contact Information

For the latest specifications, additional product information, worldwide sales and distribution locations, and information about TriQuint:

Web: www.triquint.com
Email: info-sales@tqs.com

Tel: +1.407.886.8860
Fax: +1.407.886.7061

For technical questions and application information:

Email: flapplication.engineering@tqs.com

Important Notice

The information contained herein is believed to be reliable. TriQuint makes no warranties regarding the information contained herein. TriQuint assumes no responsibility or liability whatsoever for any of the information contained herein. TriQuint assumes no responsibility or liability whatsoever for the use of the information contained herein. The information contained herein is provided "AS IS, WHERE IS" and with all faults, and the entire risk associated with such information is entirely with the user. All information contained herein is subject to change without notice. Customers should obtain and verify the latest relevant information before placing orders for TriQuint products. The information contained herein or any use of such information does not grant, explicitly or implicitly, to any party any patent rights, licenses, or any other intellectual property rights, whether with regard to such information itself or anything described by such information.

TriQuint products are not warranted or authorized for use as critical components in medical, life-saving, or life-sustaining applications, or other applications where a failure would reasonably be expected to cause severe personal injury or death.