

856992

1882.5 MHz SAW Filter

Applications

- General purpose wireless
- Wireless infrastructure
- Base Station Applications

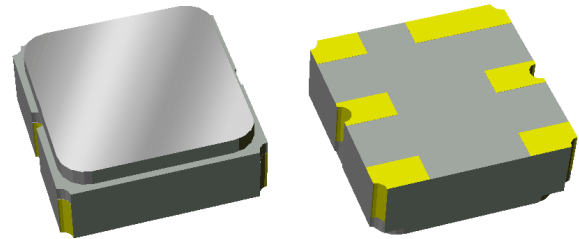

Product Features

- Usable bandwidth 65 MHz
- Low loss
- Excellent power handling
- Single-ended operation
- Ceramic Surface Mount Package (SMP)
- Matching required for operation at 50Ω
- Small Size: 3.00 x 3.00 x 1.22 mm
- Hermetically sealed
- **RoHS** compliant, **Pb**-free

General Description

856992 is a general purpose Uplink filter for Band 25. This filter was specifically designed in a 3x3mm hermetic package for base station applications and is part of our wide portfolio of RF filters in the same package.

Low insertion loss, coupled with high attenuation and excellent power handling, makes this filter a natural choice for our customers' Uplink RF filtering needs.

Functional Block Diagram

Top view

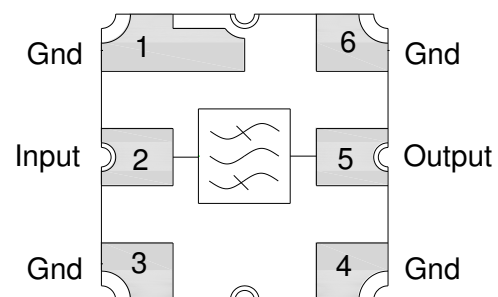

Pin Configuration

Pin # SE	Description
2	Input
5	Output
1,3,4,6	Case Ground

Ordering Information

Part No.	Description
856992	packaged part
960728-EVB	evaluation board

Standard T/R size = 5000 units/reel.

Specifications

Electrical Specifications ⁽¹⁾

Specified Temperature Range: ⁽²⁾ -30 to +100 °C

Parameter ⁽³⁾	Conditions	Min	Typical ⁽⁴⁾	Max	Units
Center Frequency		-	1882.5	-	MHz
Maximum Insertion Loss	1850 – 1915 MHz	-	1.9	2.5	dB
Amplitude Variation ⁽⁵⁾	1850 – 1915 MHz	-	0.3	1.2	dB p-p
Amplitude Variation ⁽⁵⁾ (over 5 MHz window)	1850 – 1915 MHz	-	0.14	0.8	dB p-p
Temperature Drift ⁽⁶⁾	1850 – 1915 MHz	-	0.1	0.2	dB
Absolute Group Delay	1850 – 1915 MHz	-	10	15	ns
Group Delay Variation	1850 – 1915 MHz	-	6	15	ns p-p
Phase Ripple	1850 – 1915 MHz	-	14	30	° p-p
IIP3 (Tones 5 MHz separated, power > 5 dBm per tone)	1850 – 1915 MHz	44	45	-	dBm
EVM (Any 3.84 MHz Channel)	1850 – 1915 MHz	-	0.5	1.0	%
Relative Attenuation ⁽⁷⁾	50 – 110 MHz	35	77	-	dB
	300 – 400 MHz	35	55	-	dB
	920 – 965 MHz	35	43	-	dB
	965 – 1300 MHz	25	38	-	dB
	1300 – 1635 MHz	25	34	-	dB
	1635 – 1700 MHz	25	38	-	dB
	1700 – 1790 MHz	10	25	-	dB
	2030 – 2090 MHz	20	32	-	dB
	2560 – 2635 MHz	43	45	-	dB
	4074 – 4162 MHz	20	44	-	dB
	4791 – 4879 MHz	20	36	-	dB
Input/Output VSWR	1850 – 1915 MHz	-	1.4/1.7	2:0	-
Source Impedance (single-ended) ⁽⁸⁾		-	50	-	Ω
Load Impedance (single-ended) ⁽⁸⁾		-	50	-	Ω

Notes:

- All specifications are based on the TriQuint schematic for the main reference design shown on page 3
- In production, devices will be tested at room temperature to a guardbanded specification to ensure electrical compliance over temperature
- Electrical margin has been built into the design to account for the variations due to temperature drift and manufacturing tolerances
- Typical values are based on average measurements at room temperature
- Amplitude Variation is defined as the difference between the lowest loss and the highest loss within defined frequency points
- Temperature Drift specification is defined on Page 3 and is guaranteed by design and won't be measured in production
- Relative to insertion loss at Center Frequency
- This is the optimum impedance in order to achieve the performance shown

Absolute Maximum Ratings

Parameter	Rating
Operable Temperature	-40 to +100 °C
Storage Temperature	-40 to +100 °C
Input Power ⁽⁹⁾	+22 dBm

- Power handling is targeted for an applied CW modulated RF signal at 55 °C for 125 hours

Operation of this device outside the parameter ranges given above may cause permanent damage.

Temperature Drift Specification

The Definition is:

$$Tempdrift_hightemp = \frac{\max(T_{25\ deg} - T_{100\ deg}) - \min(T_{25\ deg} - T_{100\ deg})}{2}$$

$$Tempdrift_lowtemp = \frac{\max(T_{25\ deg} - T_{-30\ deg}) - \min(T_{25\ deg} - T_{-30\ deg})}{2}$$

The Description is:

$T_{25\ deg}$ is transmission at 25 degrees in dB.

“Max” and “min” is over frequency.

The “temperature drift” is the maximum of

“tempdrift_lowtemp” and “tempdroft_hightemp”.

Reference Design – 50Ω SE Input, 50Ω SE Output

Schematic

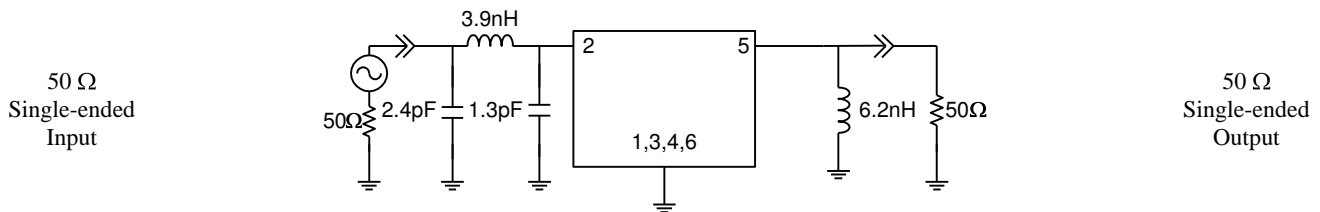

Notes:

1. Impedance matching is required
2. Actual matching values may vary due to PCB layout and parasitic

PC Board

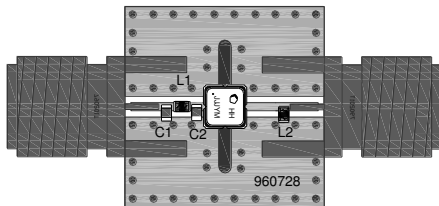

Notes:

- Top, middle & bottom layers: 1/2 oz copper
- Substrates: FR4 dielectric .063” / Taconic TLY-5A .0075”
- Finish plating: Nickel: 3-8µm thick, Gold: .03-.2µm thick
- Hole plating: Copper min .0008µm

Mounting Configuration

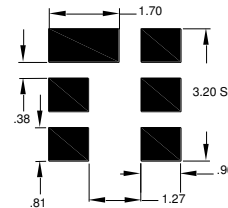

Notes:

1. All dimensions are in millimeters.
2. This footprint represents a recommendation only.

Bill of Material

Reference Desg.	Value	Description	Manufacturer	Part Number
L1	3.9nH	Coil wire-wound, 0402, 5%	MuRata	LQW15AN3N9D00
L2	6.2nH	Coil wire-wound, 0402, 5%	MuRata	LQW15AN6N2D00
C1	2.4pF	Chip Capacitor, 0402	MuRata	GRM1555C1H2R4JZ01
C2	1.3pF	Chip Capacitor, 0402	MuRata	GRM1555C1H1R3JZ01
SMA	N/A	SMA connector	Radiall USA Inc.	9602-1111-018
PCB	N/A	3-layer	multiple	960728

Typical Performance (at room temperature)

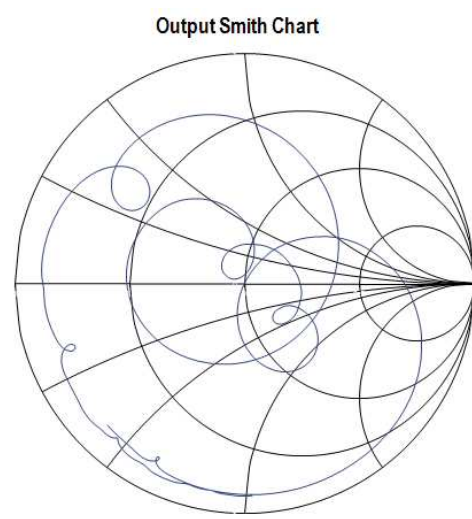
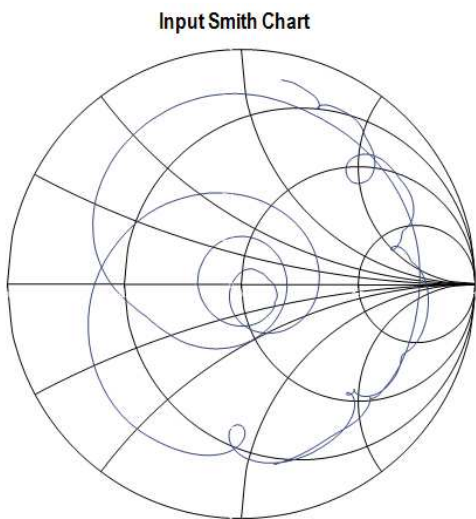
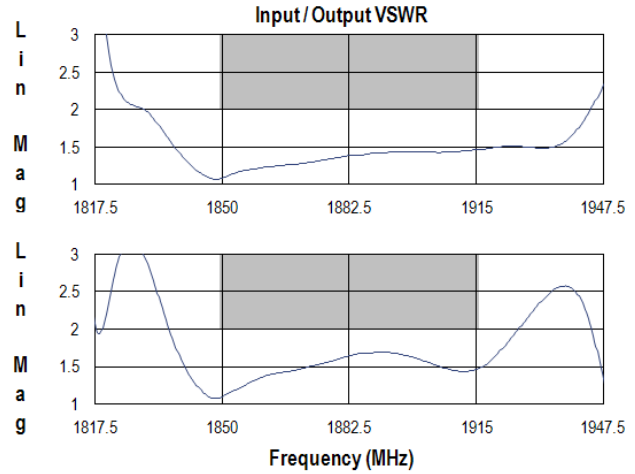
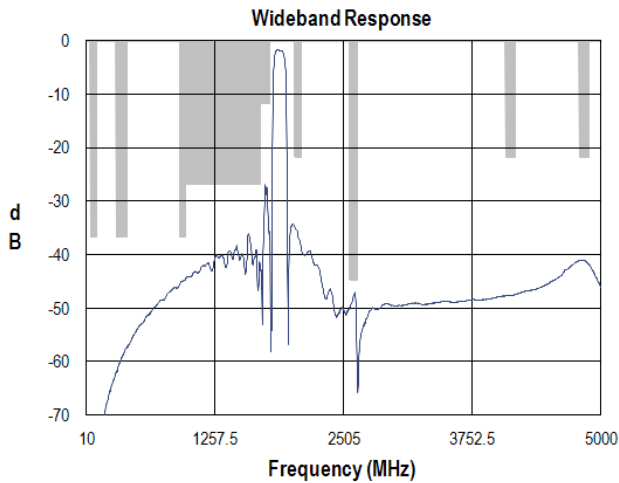
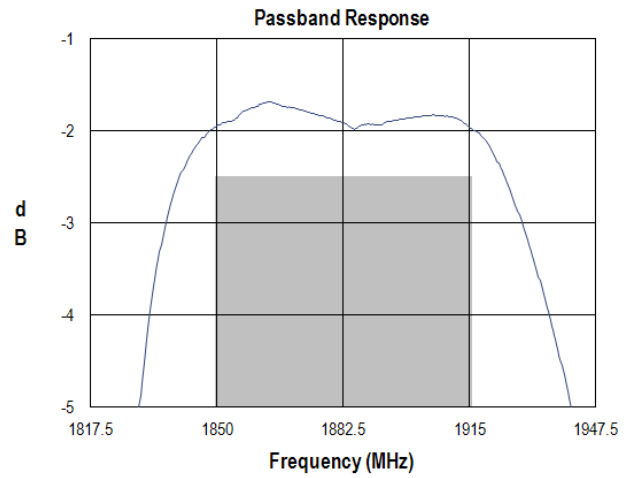
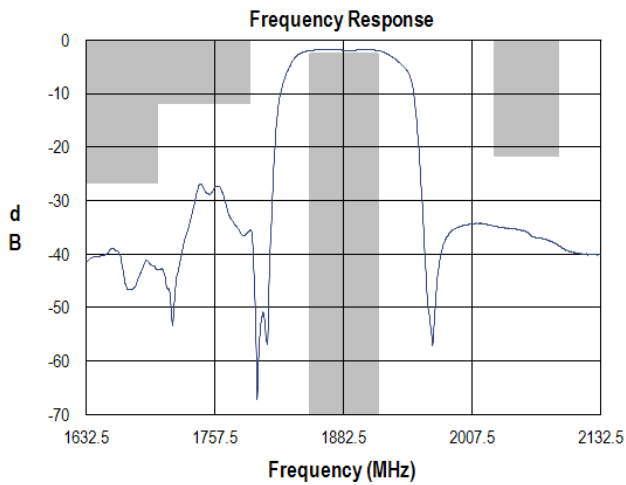

Mechanical Information

Package Information, Dimensions and Marking

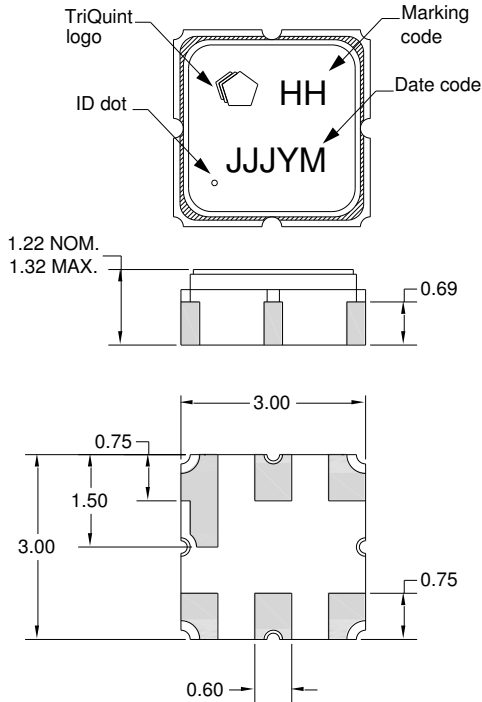

Package Style: SMP-12A
 Dimensions: 3.00 x 3.00 x 1.22 mm

Body: Al₂O₃ ceramic
 Lid: Kovar, Ni plated
 Terminations: Au plating 0.5 - 1.0µm, over a 2-6µm Ni plating

All dimensions shown are nominal in millimeters
 All tolerances are ±0.15mm except overall length and width ±0.10mm

The date code consists of day of the current year (Julian, 3 digits), Y = last digit of the year, and M = manufacturing site code

Tape and Reel Information

Standard T/R size = 5000 units/reel. All dimensions are in millimeters

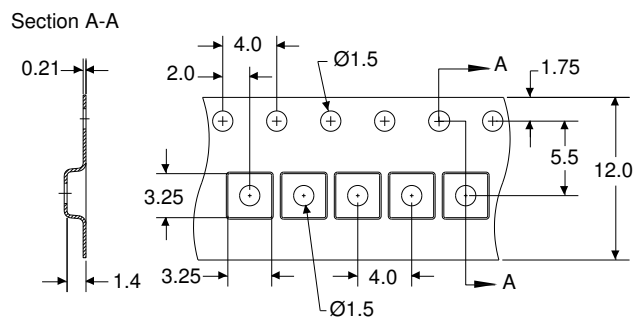
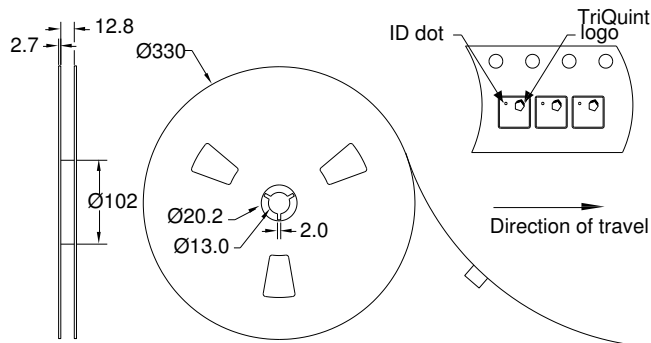

Product Compliance Information

ESD Information



Caution! ESD-Sensitive Device

ESD Rating: 1A

Value: Passes $\geq 300V$ min.
Test: Human Body Model (HBM)
Standard: JEDEC Standard JESD22-A114

ESD Rating: A

Value: Passes $\geq 150V$ min.
Test: Machine Model (MM)
Standard: JEDEC Standard JESD22-A115

MSL Rating

Devices are Hermetic, therefore MSL is not applicable

Solderability

Compatible with the latest version of J-STD-020, lead free solder, 260°C

Refer to [Soldering Profile](#) for recommended guidelines.

This part is compliant with EU 2002/95/EC RoHS directive (Restrictions on the Use of Certain Hazardous Substances in Electrical and Electronic Equipment).

This product also has the following attributes:

- Halogen Free (Chlorine, Bromine)
- Antimony Free
- TBBP-A (C₁₅H₁₂Br₄O₂) Free
- PFOS Free
- SVHC Free

Contact Information

For the latest specifications, additional product information, worldwide sales and distribution locations, and information about TriQuint:

Web: www.triquint.com **Tel:** +1.407.886.8860
Email: info-sales@tqs.com **Fax:** +1.407.886.7061

For technical questions and application information:

Email: flapplication.engineering@tqs.com

Important Notice

The information contained herein is believed to be reliable. TriQuint makes no warranties regarding the information contained herein. TriQuint assumes no responsibility or liability whatsoever for any of the information contained herein. TriQuint assumes no responsibility or liability whatsoever for the use of the information contained herein. The information contained herein is provided "AS IS, WHERE IS" and with all faults, and the entire risk associated with such information is entirely with the user. All information contained herein is subject to change without notice. Customers should obtain and verify the latest relevant information before placing orders for TriQuint products. The information contained herein or any use of such information does not grant, explicitly or implicitly, to any party any patent rights, licenses, or any other intellectual property rights, whether with regard to such information itself or anything described by such information.

TriQuint products are not warranted or authorized for use as critical components in medical, life-saving, or life-sustaining applications, or other applications where a failure would reasonably be expected to cause severe personal injury or death.