

TAT7427B

High Gain RF Amplifier, 75 Ω , 50-1200 MHz

Applications

- Distribution Amplifiers
- Multi Dwelling Units
- Drop Amplifiers
- Single Ended Gain Blocks



SOT-89 Package

Product Features

- 50-1200 MHz Bandwidth
- High Gain : 18.5 dB
- +38 dBm typical OIP3
- 2.5 dB typical NF
- Low Distortion : CSO -70dBc, CTB -88dBc tested at 10dBmV/ch at input, 80 ch NTSC
- pHEMT Device Technology
- SOT-89 Package
- Single +8V Supply

General Description

The TAT7427B is a high gain 75 Ω RF Amplifier designed for CATV applications from 50 to 1000 MHz (with operation up to 1.25GHz). The balance of low noise and distortion provides an ideal solution for drop and distribution amplifiers. It is particularly well suited for new home networks requiring higher gain for a large number of splits.

The TAT7427B is fabricated using 6-inch GaAs pHEMT technology to optimize performance and cost. It provides excellent gain and return loss consistency inherent to the pHEMT process.

Functional Block Diagram

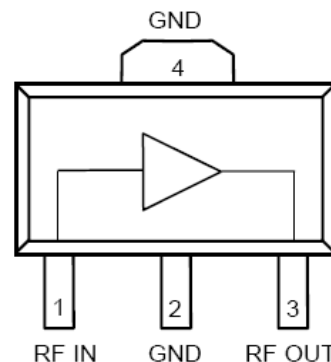

Pin Configuration

Pin #	Symbol
1	RF_Input
2, 4	Ground
3	RF_Output / V _{dd}

Ordering Information

Part No.	Description
TAT7427B-T1	High Gain 75 Ω RF Amplifier (Lead free / RoHS compliant SOT-89 Pkg)
TAT7427B-T1-EB	Drop Amplifier Evaluation Board

Standard T/R size = 1000 pieces on a 7" reel.

TAT7427B

High Gain RF Amplifier, 75 Ω , 50-1200 MHz



Specifications

Absolute Maximum Ratings

Parameter	Rating
Storage Temperature	-55 to 150 °C

Operation of this device outside the parameter ranges given above may cause permanent damage.

Recommended Operating Conditions

Parameter	Min	Typ	Max	Units
V _{dd}		8		V
Operating Case Temperature	-20		85	°C
T _i (For >10 ⁶ MTTF)			150	°C

Electrical specifications are measured at specified test conditions. Specifications are not guaranteed over all recommended operating conditions.

Electrical Specifications

Test conditions: Case Temperature 25°C

Parameter	Conditions	Min	Typical	Max	Units
Operational Frequency Range		50		1002	MHz
Gain			18.5		dB
Gain Flatness			± 0.3		dB
Noise Figure			2.5		dB
Input Return Loss			23		dB
Output Return Loss			20		dB
CSO	10 dBmV/ch at input, 80 ch NTSC flat		-70		dBc
CTB	10 dBmV/ch at input, 80 ch NTSC flat		-88		dBc
Output IP2	See Note 1.		61		dBm
Output IP3	See Note 1.		38		dBm
Supply Voltage, V _{cc}			+8		V
Device Voltage			+6		V
Supply Current, I _{dd}	See Note 2.		145	175	mA
Thermal Resistance (θ_{jc})			36		°C/W

Notes:

- OIP3 and OIP2 tested with two tones at 225 MHz and 325 MHz. Measured at 10 dBm/tone output power.
- Voltage at the device is 6V.

TAT7427B

High Gain RF Amplifier, 75 Ω , 50-1200 MHz



Typical Performance Data

Note: Temperature indicated in plots below is Case Temperature.

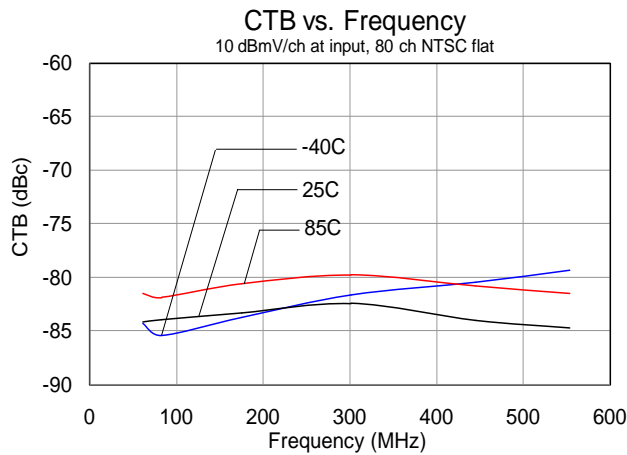
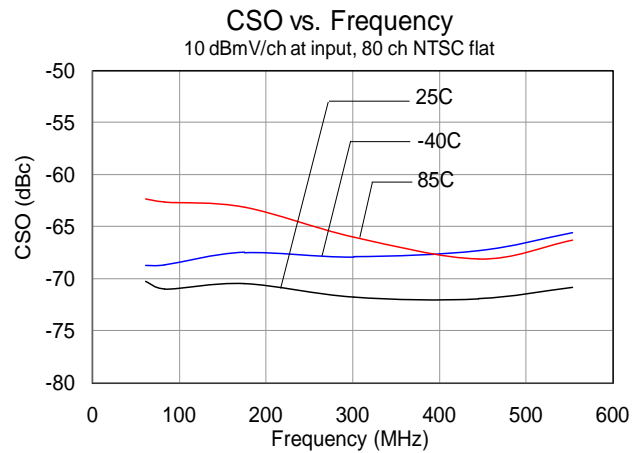
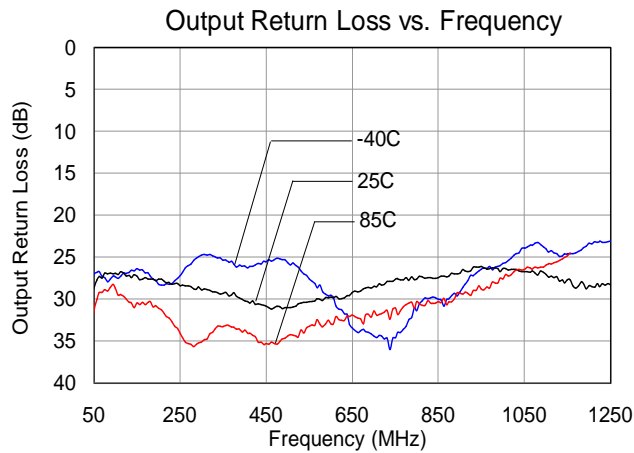
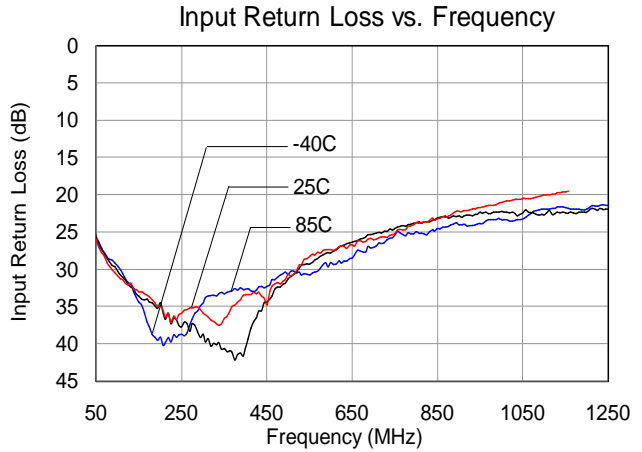
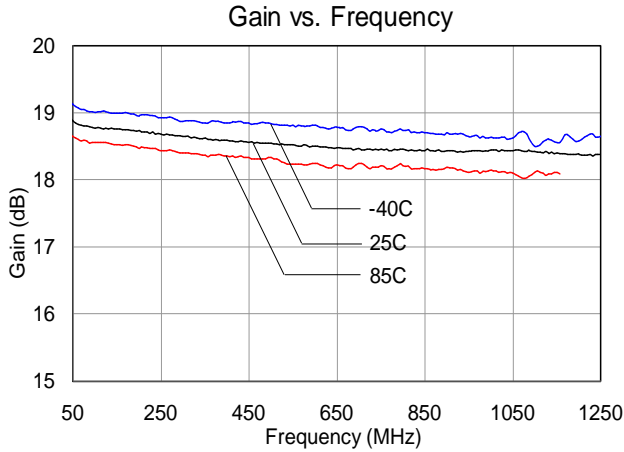

TAT7427B

High Gain RF Amplifier, 75 Ω , 50-1200 MHz

Pin Description

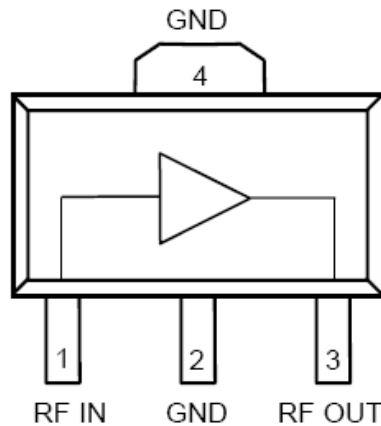

Pin	Symbol	Description
1	RF_IN	RF Input , DC voltage present, blocking capacitor required
2	GND	Ground
3	RF_OUT	RF Output , DC voltage present, blocking capacitor required
Backside Paddle	GND	Multiple vias should be employed to minimize inductance and thermal resistance

Applications Information

PC Board Layout

Core is 0.062", FR4, $\epsilon_r = 4.7$. Metal layers are 1-oz copper.

The pad pattern shown has been developed and tested for optimized assembly at TriQuint Semiconductor. The PCB land pattern has been developed to accommodate lead and package tolerances. Since surface mount processes vary from company to company, careful process development is recommended.

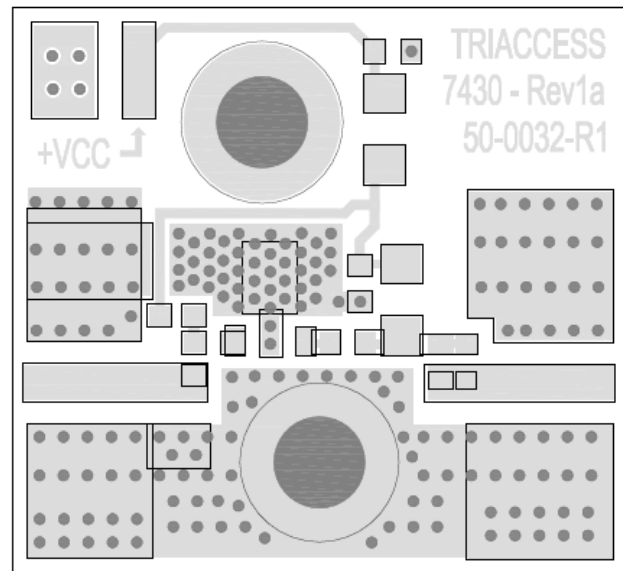

TAT7427B

High Gain RF Amplifier, 75 Ω , 50-1200 MHz

Applications Information

PC Board Schematic

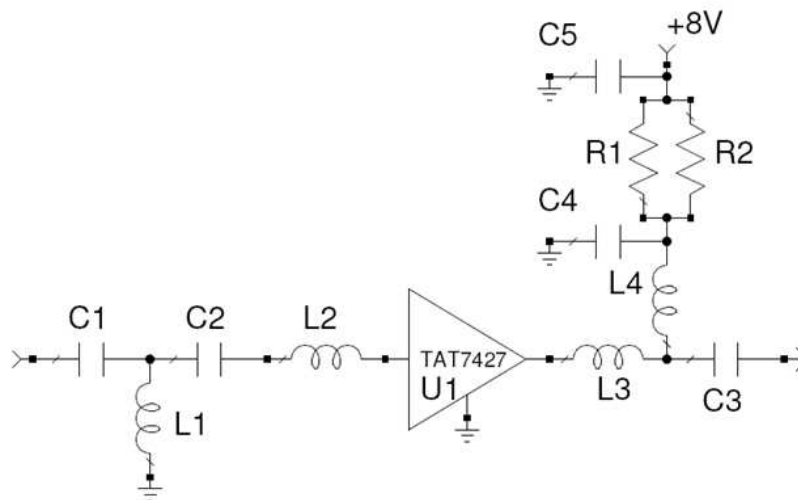

Bill of Material

Reference Desg.	Value	Description	Manufacturer	Part Number
U1		RF Amplifier, 75 ohm , 50-1000MHz	TriQuint	TAT7427B
C1, C4, C5	0.01 uF	Cap, Chip, 0603, 10%, 50V, X7R	various	
C2	680 pF	Cap, Chip, 0402, 50V, 5%, COG	various	
C3	120 pF	Cap, Chip, 0402, 50V, 5%, COG	various	
L1	880 nH	Coil, Wire Wound, 1206, $\pm 10\%$	various	
L2	3.9 nH	Inductor, Chip, 0603, 5%	various	
L3	5.6 nH	Inductor, Chip, 0603, 5%	various	
L4	500 nH	Coil, Wire Wound, 1206, $\pm 10\%$	various	
R1, R2	16 Ω	Resistor, Chip, 1206, $\pm 5\%$, 1/4W	various	

TAT7427B

High Gain RF Amplifier, 75 Ω, 50-1200 MHz



Mechanical Information

Package Information and Dimensions

This package is lead-free, RoHS-compliant, and green. The plating material on the pins is 100% matte tin. It is compatible with both lead-free (maximum 260 °C reflow temperature) and leaded (maximum 245 °C reflow temperature) soldering processes.

The TAT7427B will be marked with a “TAT7427B” designator and an 8 digit alphanumeric lot code (XXXXYYWW). The first 4 digits (XXXX) are the lot code. The last 4 digits (YYWW) are the date code consisting of the year and work week of assembly.

SYMBOL	MIN	NOM	MAX
A - Thickness	1.40	1.50	1.60
C - Lead thickness	0.35		0.43
D - Body width	4.40		4.60
E1 - Body length	2.30		2.60
E - Total length	3.64		4.25
e - Lead spacing	1.40	1.50	1.60
e1 - Dual lead spacing	2.90	3.00	3.10
b - Outer lead width	0.35		0.48
b1 - Center lead width	0.40		0.56
L - Lead length	0.74		1.20
d1 - Tab lead width	1.40		1.80
Above body	0.35		0.64

DIMENSIONS ARE IN MM

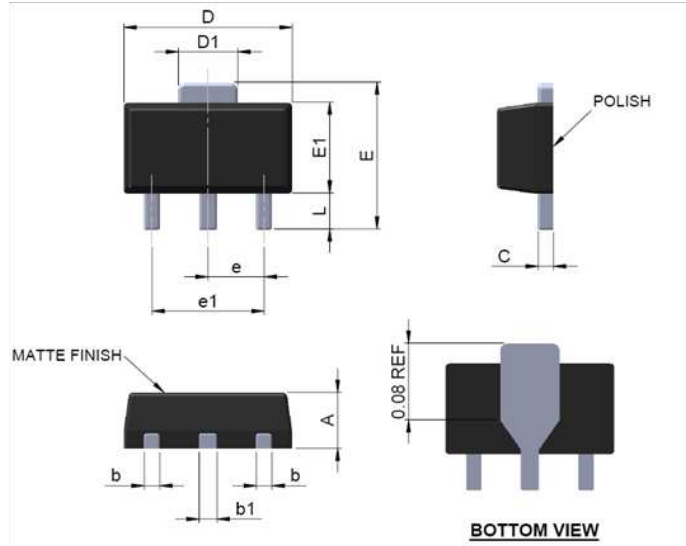

Mounting Configuration

All dimensions are in millimeters (inches). Angles are in degrees.

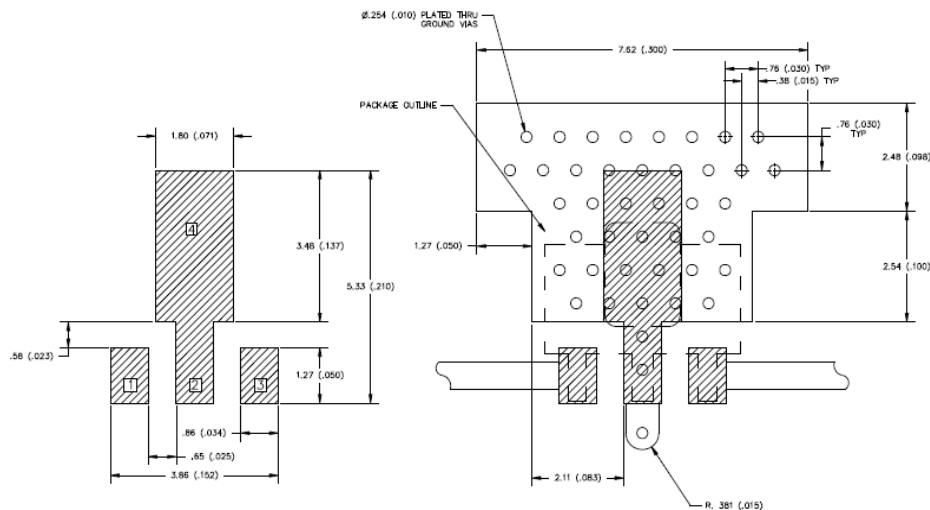

Notes:

1. Ground / thermal vias are critical for the proper performance of this device. Vias should use a .35mm (#80 / .0135”) diameter drill and have a final plated thru diameter of .25 mm (.010”).
2. Add as much copper as possible to inner and outer layers near the part to ensure optimal thermal performance.

TAT7427B

High Gain RF Amplifier, 75 Ω , 50-1200 MHz

Product Compliance Information

ESD Information



Caution! ESD-Sensitive Device

ESD Rating: Class 1B
Value: Passes $\geq 500V$ min.
Test: Human Body Model (HBM)
Standard: JEDEC Standard JESD22-A114

ESD Rating: Class IV
Value: Passes $\geq 2000 V$
Test: Charged Device Model (CDM)
Standard: JEDEC Standard JESD22-C101

MSL Rating

MSL 3 at +260 °C convection reflow
The part is rated Moisture Sensitivity Level 3 at 260°C per JEDEC standard IPC/JEDEC J-STD-020.

Solderability

Compatible with the latest version of J-STD-020, Lead free solder, 260°

This part is compliant with EU 2002/95/EC RoHS directive (Restrictions on the Use of Certain Hazardous Substances in Electrical and Electronic Equipment).

This product also has the following attributes:

- Lead Free
- Halogen Free (Chlorine, Bromine)
- Antimony Free
- TBBP-A (C₁₅H₁₂Br₄O₂) Free
- PFOS Free
- SVHC Free

Contact Information

For the latest specifications, additional product information, worldwide sales and distribution locations, and information about TriQuint:

Web: www.triquint.com
Email: info-sales@tqs.com

Tel: +1.707.526.4498
Fax: +1.707.526.1485

For technical questions and application information:

Email: sjapplications.engineering@tqs.com

Important Notice

The information contained herein is believed to be reliable. TriQuint makes no warranties regarding the information contained herein. TriQuint assumes no responsibility or liability whatsoever for any of the information contained herein. TriQuint assumes no responsibility or liability whatsoever for the use of the information contained herein. The information contained herein is provided "AS IS, WHERE IS" and with all faults, and the entire risk associated with such information is entirely with the user. All information contained herein is subject to change without notice. Customers should obtain and verify the latest relevant information before placing orders for TriQuint products. The information contained herein or any use of such information does not grant, explicitly or implicitly, to any party any patent rights, licenses, or any other intellectual property rights, whether with regard to such information itself or anything described by such information.

TriQuint products are not warranted or authorized for use as critical components in medical, life-saving, or life-sustaining applications, or other applications where a failure would reasonably be expected to cause severe personal injury or death.