

# TGS2352

## DC – 12 GHz High Power SPDT Switch

### Applications

- High Power Switching

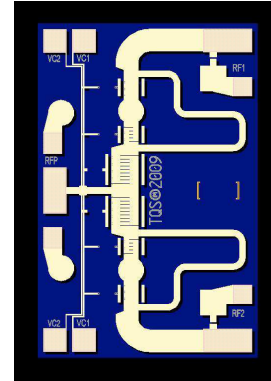

### Product Features

- Frequency Range: DC – 12 GHz
- Input Power: up to 20 W
- Insertion Loss: < 1 dB
- Isolation: -35 dB typical
- Switching Speed: < 35 ns
- Control Voltages: 0 V/-40 V from either side of MMIC
- Dimensions: 1.15 x 1.65 x 0.1 mm

### Functional Block Diagram

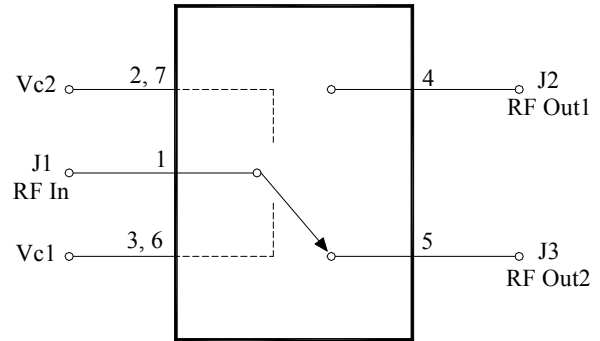

### General Description

The TriQuint TGS2352 is a Single-Pole, Double-Throw (SPDT) Switch. The TGS2352 operates from DC to 12 GHz and is designed using TriQuint's 0.25um GaN on SiC production process.

The TGS2352 typically provides up to 20 W input power handling at control voltages of 0/-40 V. This switch maintains low insertion loss 1 dB, and high isolation -35 dB typical.

The TGS2352 is ideally suited for High Power Switching application.

Lead-free and RoHS compliant

### Bond Pad Configuration

Bond Pad #	Symbol
1	RF In
2, 7	Vc2
3, 6	Vc1
4	RF Out1
5	RF Out2

### Ordering Information

Part No.	ECCN	Description
TGS2352	EAR99	DC – 12 GHz High Power SPDT Switch

# TGS2352

## DC – 12 GHz High Power SPDT Switch

### Specifications

#### Absolute Maximum Ratings

Parameter	Rating
Control Voltage, Vc	- 50 V
Control Current, Ic	-1 to 9.8 mA
Power Dissipation, P <sub>diss</sub>	5 W
RF Input Power, CW, 50Ω, T = 25°C	44 dBm
Channel Temperature, T <sub>ch</sub>	275 °C
Mounting Temperature (30 Seconds)	320 °C
Storage Temperature	-40 to 150 °C

Operation of this device outside the parameter ranges given above may cause permanent damage. These are stress ratings only, and functional operation of the device at these conditions is not implied.

#### Recommended Operating Conditions

Parameter	Min	Typical	Max	Units
Vc1		-40 / 0		V
Vc2		0 / -40		V
Ic1 / Ic2		-0.3 to 0.1		mA

Electrical specifications are measured at specified test conditions. Specifications are not guaranteed over all recommended operating conditions.

#### Electrical Specifications

Test conditions unless otherwise noted: 25°C, Vc1 = -40/0 V, Vc2 = 0/-40 V, see Function Table at Application Circuit on page 5.

Parameter	Min	Typical	Max	Units
Operational Frequency Range	DC		12	GHz
Control Current (Ic1/ Ic2)	-0.65		0.1	mA
Insertion Loss (On-State)		< 1		dB
Input Return Loss – On-State (Common Port RL)		15		dB
Output Return Loss – On-State (Switched Port RL)		15		dB
Isolation (Off-State)		-35		dB
Output Return Loss – Off-Sate (Isolated Port RL)		3		dB
Input Power <sup>1/</sup>		43		dBm
Insertion Loss Temperature Coefficient		-0.003		dB/°C
Switching Speed - On		31		ns
Switching Speed - Off		18		ns

1/ The Input Power will be reduced if < 10 MHz.

### Specifications (cont.)

#### Thermal and Reliability Information

Parameter	Condition	Rating
Thermal Resistance, $\theta_{JC}$ , measured to back of carrier (die mounted to a 20 mil CuMo carrier using 1.5 mil 80/20 AuSn)	Tbase = 70 °C	$\theta_{JC} = 12.6 \text{ }^{\circ}\text{C/W}$
Channel Temperature (Tch), and Median Lifetime (Tm)	Tbase = 70 °C, Vc1 = 0 V, Vc2 = -40 V, Pin = 20 W, Pdiss = 4.15 W	Tch = 122.3 °C Tm = 9.2 E+8 Hours

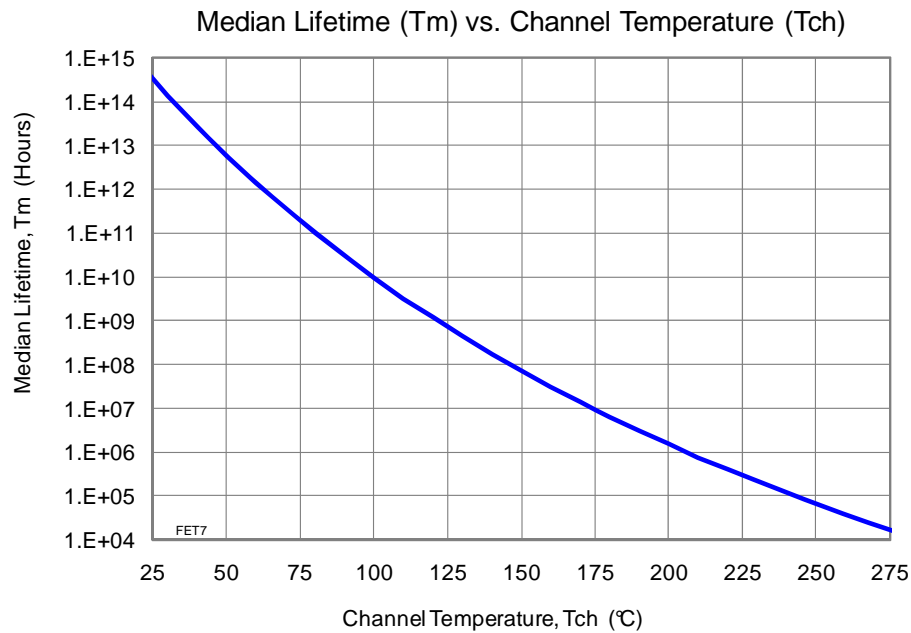

# TGS2352

## DC – 12 GHz High Power SPDT Switch



### Typical Performance

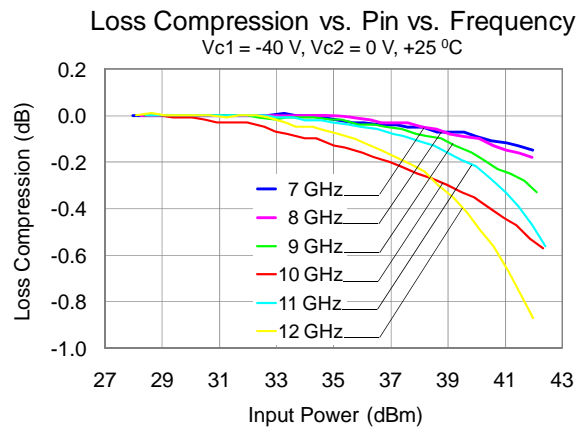
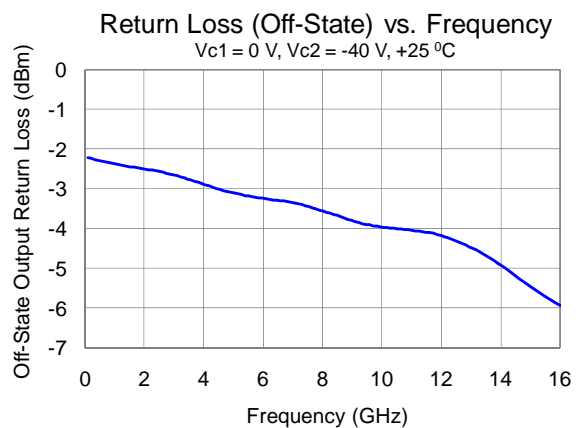
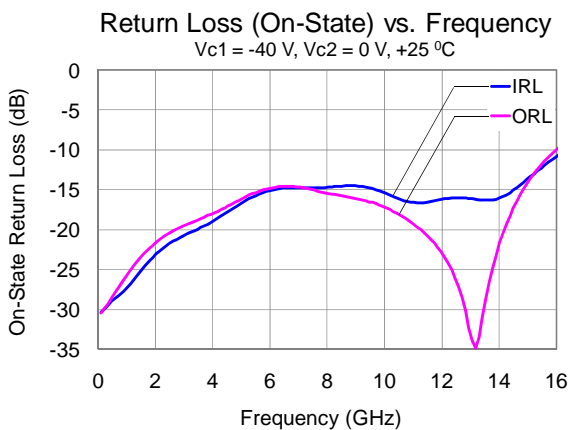
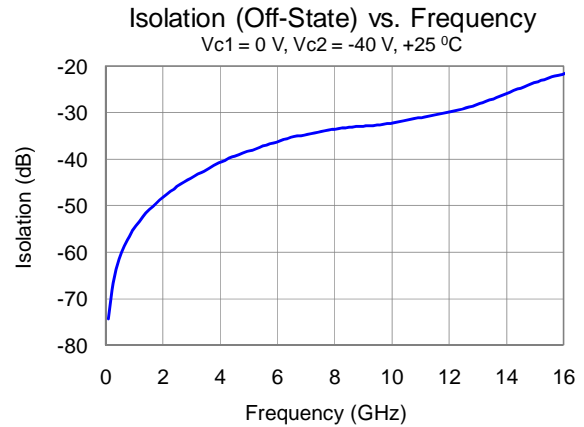
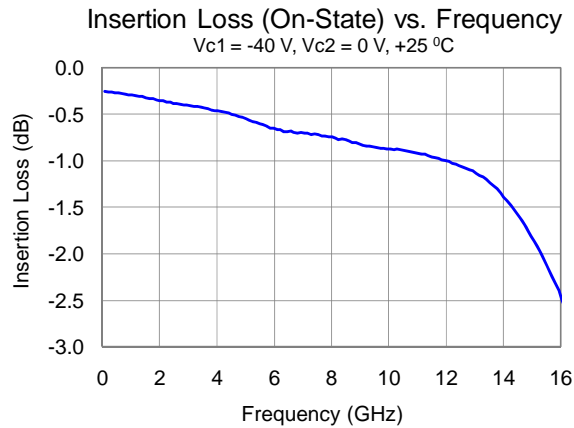

# TGS2352

DC – 12 GHz High Power SPDT Switch

## Application Circuit

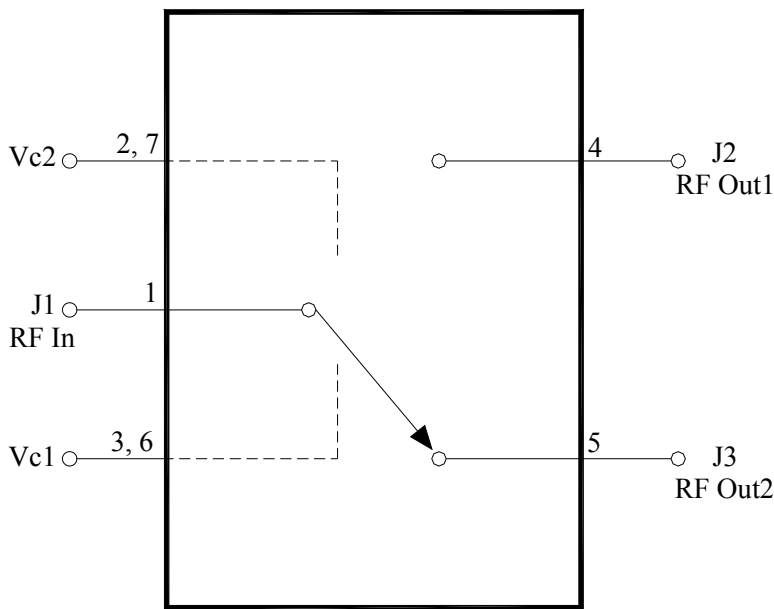

Vc1 can be biased from either bond pad 3 or 6, and the non-biased bond pad can be left open.  
 Vc2 can be biased from either bond pad 2 or 7, and the non-biased bond pad can be left open.

This switch can be configured as a Single Pole, Single Throw (SPST) by terminating one unused RF Out port with a 50 Ohm load.

Bias-up Procedure	Bias-down Procedure
Vc1 set to -40 V (On State for Insertion Loss) or 0 V (OFF State for Isolation)	Turn off RF supply
Vc2 set to 0 V (On State for Insertion Loss) or -40 V (OFF State for Isolation)	Turn Vc1 to 0V
Apply RF signal to RF Input	Turn Vc2 to 0 V

## Function Table

RF Path	State	Vc1	Vc2
RF In to RF Out1 (50 Ohm load to RF Out2)	On-State (Insertion Loss)	0 V	-40 V
	Off-State (Isolation)	-40 V	0 V
RF In to RF Out2 (50 Ohm load to RF Out1)	On-State (Insertion Loss)	-40 V	0 V
	Off-State (Isolation)	0 V	-40 V

# TGS2352

DC – 12 GHz High Power SPDT Switch

## Bond Pad Description

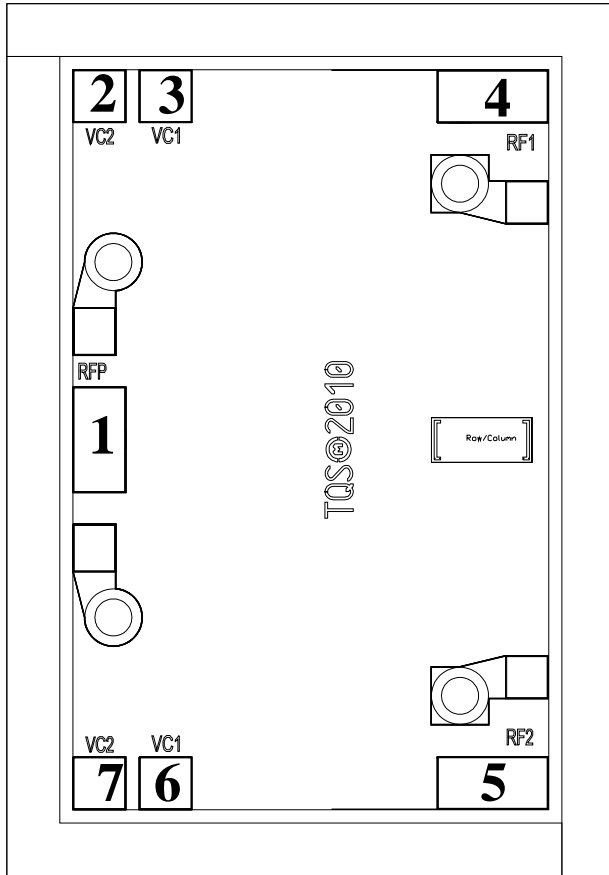

Bond Pad	Symbol	Description
1	RF In	Input, matched to 50 ohms, DC coupled
2, 7	Vc2	Control voltage #2; can be biased from either side (bond pad 2 or bond pad 7), and non-biased bond pad can be left opened; see Application Circuit on page 5 as an example
3, 6	Vc1	Control voltage #1; can be biased from either side (bond pad 3 or bond pad 6), and non-biased bond pad can be left opened; see Application Circuit on page 5 as an example
4	RF Out1	Output #1, matched to 50 ohms, DC coupled
5	RF Out2	Output #2, matched to 50 ohms, DC coupled

# TGS2352

DC – 12 GHz High Power SPDT Switch

## Assembly Drawing

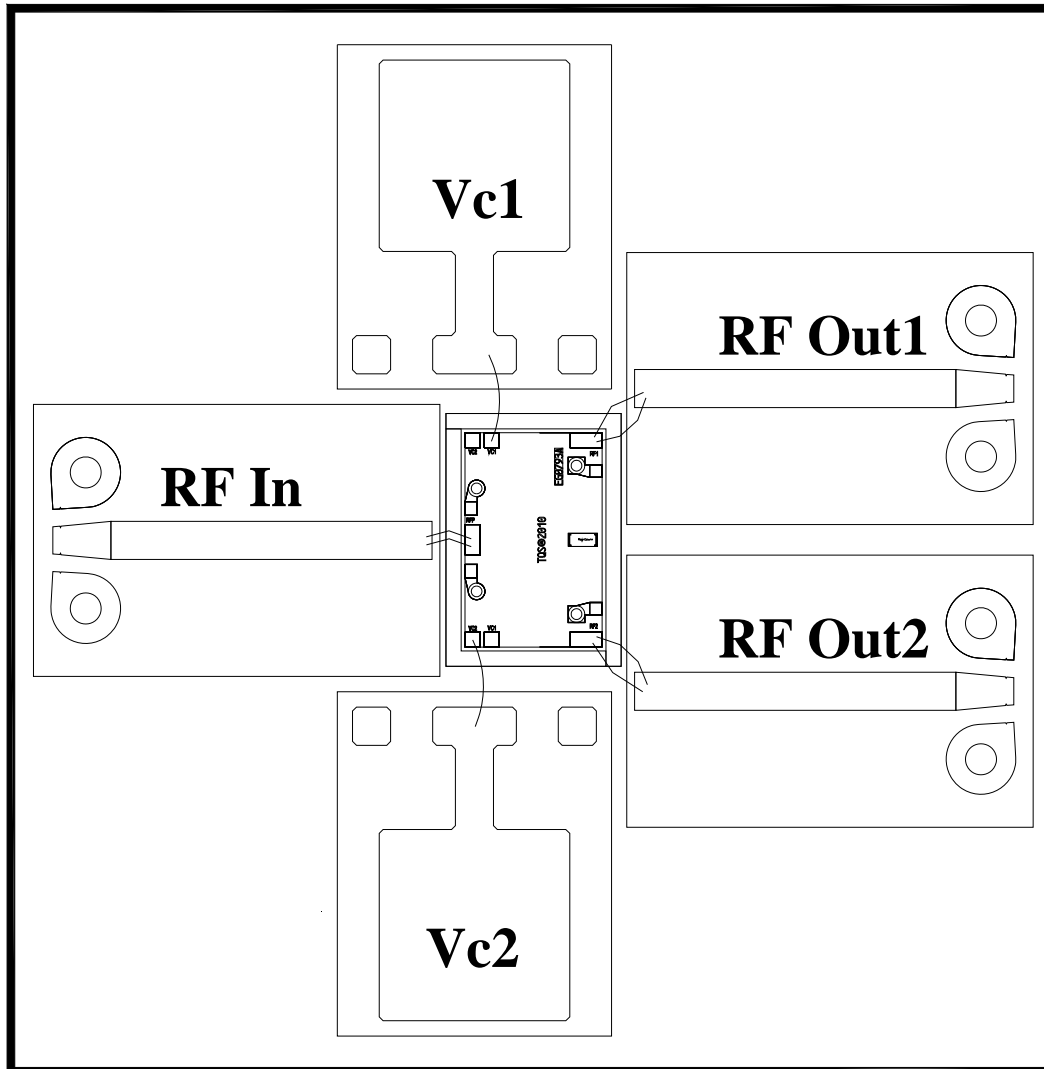

# TGS2352

DC – 12 GHz High Power SPDT Switch

## Mechanical Information

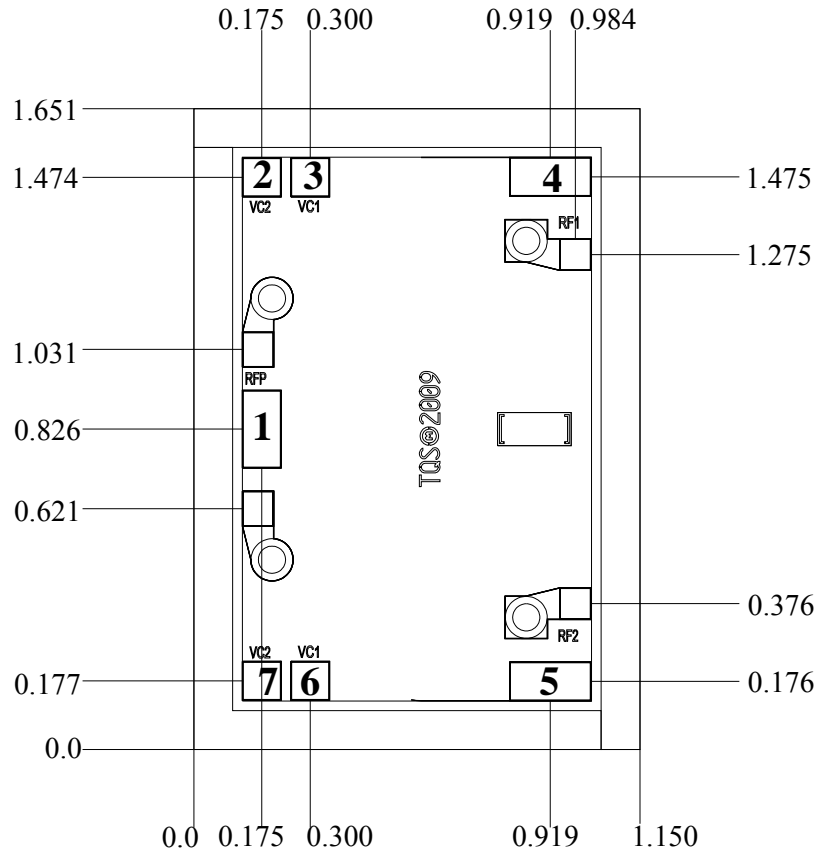

Unit: millimeters  
 Thickness: 0.10  
 Die x, y size tolerance: +/- 0.050  
 Chip edge to bond pad dimensions are shown to center of pad  
 Ground is backside of die

Bond Pad	Symbol	Pad Size
1	RF In	0.100 x 0.200
2, 7	Vc2	0.100 x 0.100
3, 6	Vc1	0.100 x 0.100
4	RF Out1	0.200 x 0.100
5	RF Out2	0.200 x 0.100



### Product Compliance Information

#### ESD Information



#### Caution! ESD-Sensitive Device

ESD Rating: TBD  
Value: Passes  $\geq$  TBD V min.  
Test: Human Body Model (HBM)  
Standard: JEDEC Standard JESD22-A114

#### ECCN

US Department of Commerce EAR99

#### Solderability

This part is compliant with EU 2002/95/EC RoHS directive (Restrictions on the Use of Certain Hazardous Substances in Electrical and Electronic Equipment).

This product also has the following attributes:

- Lead Free
- Halogen Free (Chlorine, Bromine)
- Antimony Free
- TBBP-A (C<sub>15</sub>H<sub>12</sub>Br<sub>4</sub>O<sub>2</sub>) Free
- PFOS Free
- SVHC Free

### Assembly Notes

Component placement and adhesive attachment assembly notes:

- Vacuum pencils and/or vacuum collets are the preferred method of pick up.
- Air bridges must be avoided during placement.
- The force impact is critical during auto placement.
- Organic attachment (i.e. epoxy) can be used in low-power applications.
- Curing should be done in a convection oven; proper exhaust is a safety concern.

Reflow process assembly notes:

- Use AuSn (80/20) solder and limit exposure to temperatures above 300°C to 3-4 minutes, maximum.
- An alloy station or conveyor furnace with reducing atmosphere should be used.
- Do not use any kind of flux.
- Coefficient of thermal expansion matching is critical for long-term reliability.
- Devices must be stored in a dry nitrogen atmosphere.

Interconnect process assembly notes:

- Thermosonic ball bonding is the preferred interconnect technique.
- Force, time, and ultrasonics are critical parameters.
- Aluminum wire should not be used.
- Devices with small pad sizes should be bonded with 0.0007-inch wire.

# TGS2352

## DC – 12 GHz High Power SPDT Switch



### Contact Information

For the latest specifications, additional product information, worldwide sales and distribution locations, and information about TriQuint:

Web: [www.triquint.com](http://www.triquint.com)  
Email: [info-sales@tqs.com](mailto:info-sales@tqs.com)

Tel: +1.972.994.8465  
Fax: +1.972.994.8504

For technical questions and application information:

Email: [info-products@tqs.com](mailto:info-products@tqs.com)

### Important Notice

The information contained herein is believed to be reliable. TriQuint makes no warranties regarding the information contained herein. TriQuint assumes no responsibility or liability whatsoever for any of the information contained herein. TriQuint assumes no responsibility or liability whatsoever for the use of the information contained herein. The information contained herein is provided "AS IS, WHERE IS" and with all faults, and the entire risk associated with such information is entirely with the user. All information contained herein is subject to change without notice. Customers should obtain and verify the latest relevant information before placing orders for TriQuint products. The information contained herein or any use of such information does not grant, explicitly or implicitly, to any party any patent rights, licenses, or any other intellectual property rights, whether with regard to such information itself or anything described by such information.

TriQuint products are not warranted or authorized for use as critical components in medical, life-saving, or life-sustaining applications, or other applications where a failure would reasonably be expected to cause severe personal injury or death.