

TQM879026

0.7–4 GHz 1/4W Digital Variable Gain Amplifier



Applications

- 3G / 4G Wireless Infrastructure
- CDMA, WCDMA, LTE
- Repeaters

Product Features

- 0.7-4.0 GHz Frequency Range
- 32 dB Maximum Gain at 2.14 GHz
- 31.5 dB Gain Range in 0.5 dB Steps
- +42.5 dBm Output IP3
- +24 dBm Output P1dB
- 1.6 dB Noise Figure
- 3-wire SPI Control Programming

General Description

The TQM879026 is a digital variable gain amplifier (DVGA) featuring high linearity and digital variable gain control in 0.5 dB step sizes. This DVGA integrates a gain block, a digital-step attenuator (DSA), and a high linearity 1/4-watt amplifier into a compact 4x4 mm package. The internal 6-bit DSA provides a 31.5 dB gain control range and is controlled with a serial periphery interface (SPI™). The individual stages are accessible to external ports to allow for optimization of the last stage amplifier for individual bands and also allowing other functional blocks to be added in-between the stages.

The TQM879026 features variable gain from 1 dB to 32 dB at 2.14 GHz, +42.5 dBm output IP3, and +24 dBm P1dB while only consuming 176 mA current from a 5V supply. The module is available in a compact 24-pin 4x4 mm leadless SMT package.

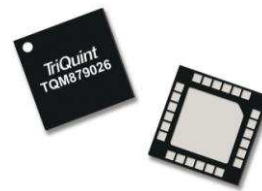

4x4 mm 24 Pin leadless SMT Package

Functional Block Diagram

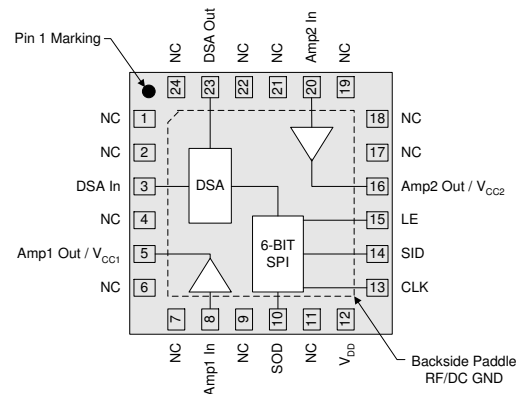

Pin Configuration

Pin No.	Symbol
1,2,4,6,7,9,11,17,18,19,21,22,24	NC (No Connect)
3	DSA In
5	Amp1 Out / Vcc1
8	Amp1 In
10	SOD
12	V _{DD}
13	CLK
14	SID
15	LE
16	Amp2 Out / Vcc2
20	Amp2 In
23	DSA Out
Backside Paddle	RF/DC Ground

Ordering Information

Part No.	Description
TQM879026	1/4 W 0.7-4.0 GHz DVGA
TQM879026-PCB2140	2140 MHz Evaluation Board Includes USB control board

Standard T/R size = 2500 pieces on a 13" reel

TQM879026

0.7–4 GHz 1/4W Digital Variable Gain Amplifier



Absolute Maximum Ratings

Parameter	Rating
Storage Temperature	-55 to 150 °C
RF Input Power, CW, 50Ω, T=25 °C	+12 dBm
Supply Voltage (V _{DD})	+5.5 V
Digital Input Voltage	V _{DD} + 0.5 V

Operation of this device outside the parameter ranges given above may cause permanent damage.

Recommended Operating Conditions

Parameter	Min	Typ	Max	Units
Supply Voltage (V _{DD})	4.75	5.0	5.25	V
T _{CASE}	-40		+85	°C
T _j for >10 ⁶ hours MTTF			+170	°C

Electrical specifications are measured at specified test conditions. Specifications are not guaranteed over all recommended operating conditions.

Electrical Specifications

Test conditions unless otherwise noted: V_{DD} = +5V, Temp = +25 °C, matched 2140 MHz reference circuit, max. gain setting.

Parameter	Conditions	Min	Typ	Max	Units
Operational Frequency Range		700		4000	MHz
Test Frequency			2140		MHz
Gain		29	32	35	dB
Gain Control Range	0.5 dB Step Size		31.5		dB
Accuracy Error		±(0.3+5% of Attenuation setting)			dB
Input Return Loss			17		dB
Output Return Loss			13		dB
Output P1dB			+24		dBm
Output IP3	P _{out} = +11 dBm/tone, Δf = 1 MHz	+38	+42.5		dBm
Noise Figure			1.5		dB
Supply Current	See Note 1	140	176	211	mA
Thermal Resistance, θ _{jc}	Module (junction to case)			36.7	°C/W

Notes:

1. Amp1 current (pin 5) is typically 84 mA. Amp2 current (pin 16) is typically 90 mA. DSA current (pin 12) is typically 2 mA.

TQM879026

0.7–4 GHz 1/4W Digital Variable Gain Amplifier



Serial Control Interface

The TQM879026 has a CMOS SPI™ input compatible serial interface. This serial control interface converts the serial data input stream to parallel output word. The input is 3-wire (CLK, LE and SID) SPI™ input compatible. At power up, the serial control interface resets the DSA to the minimum gain state. The 6-bit SID (Serial Input Data) word is loaded into the register on rising edge of the CLK, MSB first. When LE is high, CLK is internally disabled.

Serial Control Timing Characteristics (Test conditions: V_{DD} = +5 V, Temp.=25°C)

Parameter	Condition	Min	Max	Units
Clock Frequency	50% Duty Cycle		10	MHz
LE Setup Time, t _{LESUP}	after last CLK rising edge	10		ns
LE Pulse Width, t _{LEPW}		30		ns
SID set-up time, t _{SDSUP}	before CLK rising edge	10		ns
SID hold-time, t _{SDHLD}	after CLK rising edge	10		ns
LE Pulse Spacing t _{LE}	LE to LE pulse spacing	630		ns
Propagation Delay t _{PLO}	LE to Parallel output valid		30	ns

Serial Control DC Logic Characteristics (Test conditions: V_{DD} = +5 V, Temp.=25°C)

Parameter	Condition	Min	Max	Units
Input Low State Voltage, V _{IL}		0	0.8	V
Input High State Voltage, V _{IH}		2.4	V _{DD}	V
Output High State Voltage, V _{OH}	On SOD pin	2.0	V _{DD}	V
Output Low State Voltage, V _{OL}	On SOD pin	0	0.8	V
Input Current, I _{IH} / I _{IL}	On SID, LE and CLK pins	-10	+10	μA

SID Control Logic Truth Table

6-Bit Control Word						Gain Relative to Maximum Gain
MSB			LSB			
D5	D4	D3	D2	D1	D0	
1	1	1	1	1	1	Maximum Gain
1	1	1	1	1	0	-0.5 dB
1	1	1	1	0	1	-1 dB
1	1	1	0	1	1	-2 dB
1	1	0	1	1	1	-4 dB
1	0	1	1	1	1	-8 dB
0	1	1	1	1	1	-16 dB
0	0	0	0	0	0	-31.5 dB

Any combination of the possible 64 states will provide a reduction in gain of approximately the sum of the bits selected.

Timing Diagram

CLK is internally disabled when LE is high

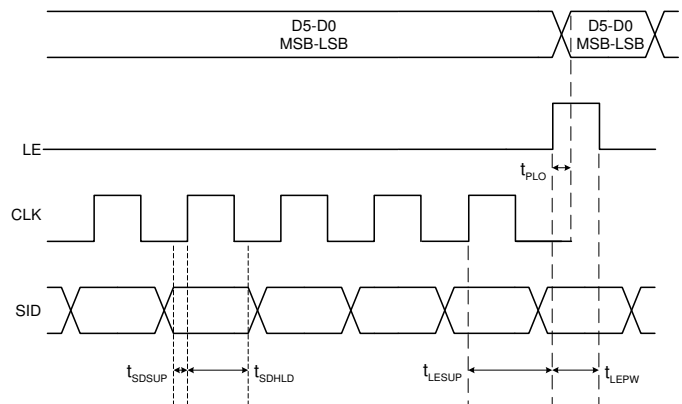

TQM879026

0.7–4 GHz 1/4W Digital Variable Gain Amplifier



TQM879026-PCB2140 Evaluation Board

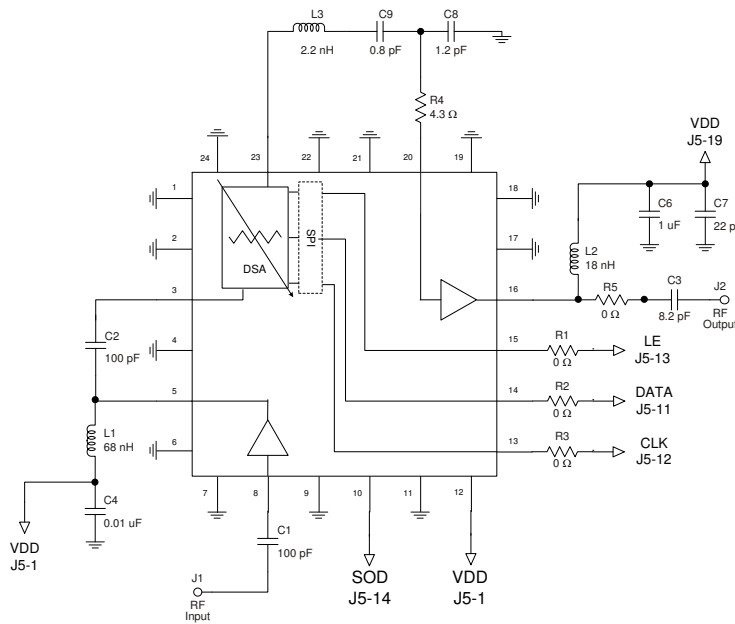
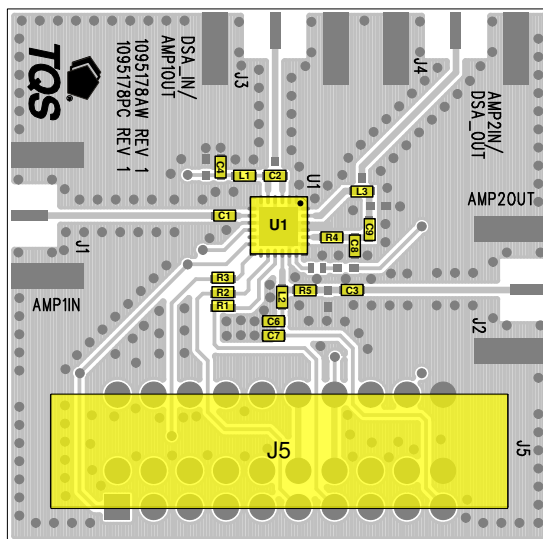

Bill of Material - TQM879026-PCB2140

Reference Des.	Value	Description	Manuf.	Part Number		
U1	n/a	1/4 W DVGA	TriQuint	TQM879026		
C1, C2	100 pF	Cap 0402 5% 50V NPO/COG	various			
C3	8.2 pF	Cap 0402 ±0.1 pF 50V NPO/COG	AVX	04025U8R2BAT2A		
C4	0.01 uF	Cap 0402 ±10% 16V X7R	various			
C6	1 uF	Cap 0402 ±10% 10V X5R	various			
C7	22 pF	Cap 0402 5% 50V NPO/COG	various			
C8	1.2 pF	Cap 0402 ±0.1 pF 25V NPO/COG	AVX	04023U1R2CAT2A		
C9	0.8 pF	Cap 0402 ±0.075 pF 25V NPO/COG	AVX	04025U0R8BAT2A		
L1	68 nH	Ind 0402	various			
L2	18 nH	Ind 0402	various			
L3	2.2 nH	Ind 0402	various			
R1, R2, R3, R5	0 Ω	R4	4.3 Ω	Res 0402	various	
R4	4.3 Ω	Res 0402	various			

TQM879026

0.7–4 GHz 1/4W Digital Variable Gain Amplifier



Typical Performance TQM879026-PCB2140

Test conditions unless otherwise noted: $V_{DD} = +5V$, Temp= +25°C, DSA at max. gain setting

Parameter	Conditions	Typical Value			Units
Frequency		2110	2140	2170	MHz
Gain		32.6	32.6	32.6	dB
Input Return Loss		18	18	18	dB
Output Return Loss		15	14	13	dB
Output P1dB		23.8	23.9	24.0	dBm
OIP3	Pout= +11 dBm/tone, $\Delta f=1$ MHz	42.8	42.5	43	dBm
Noise figure		1.6	1.6	1.6	dB

Performance Plots - TQM879026-PCB2140

Test conditions unless otherwise noted: $V_{DD} = +5V$, Temp= +25°C

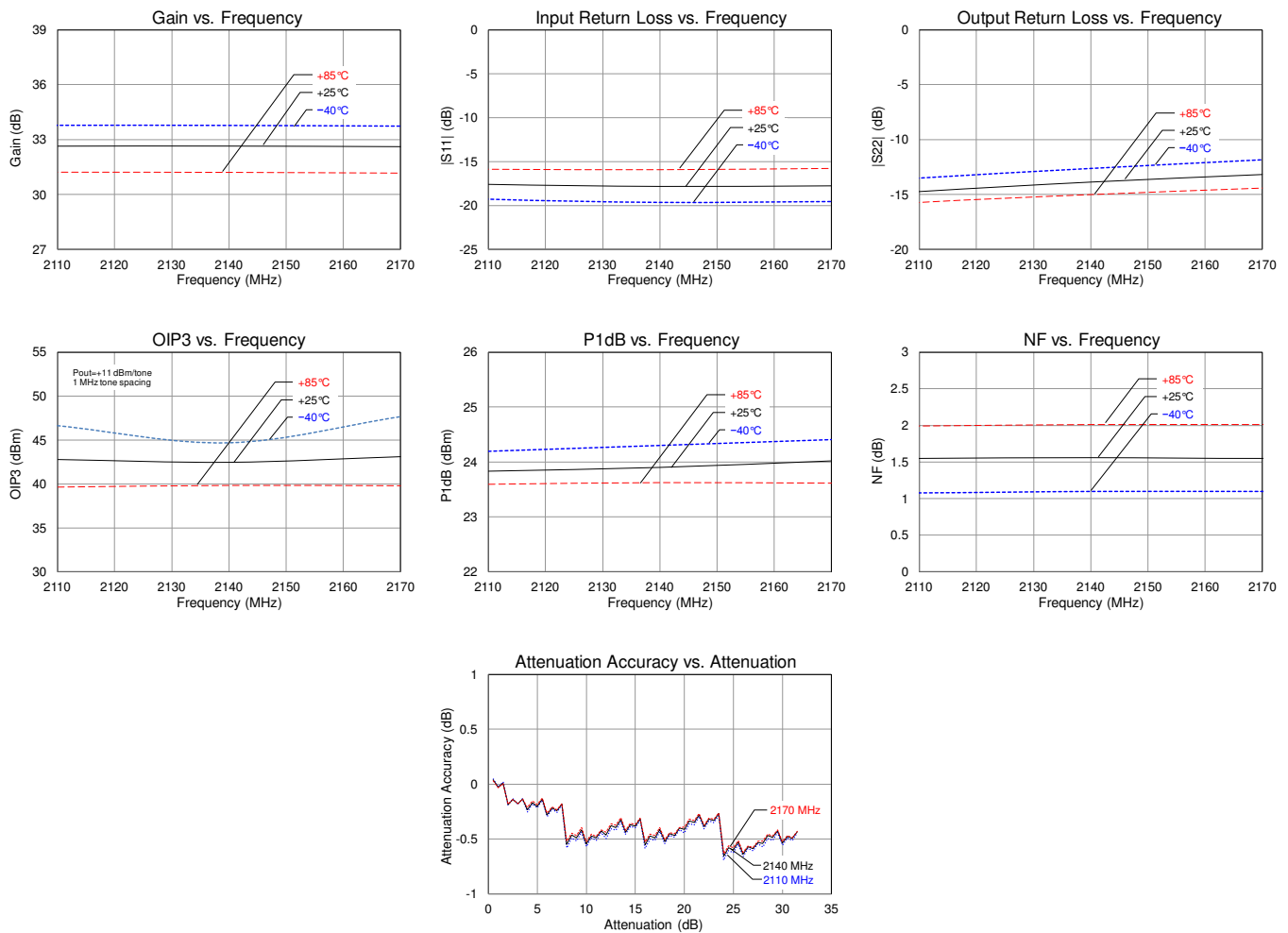

TQM879026

0.7–4 GHz 1/4W Digital Variable Gain Amplifier



Pin Configuration and Description

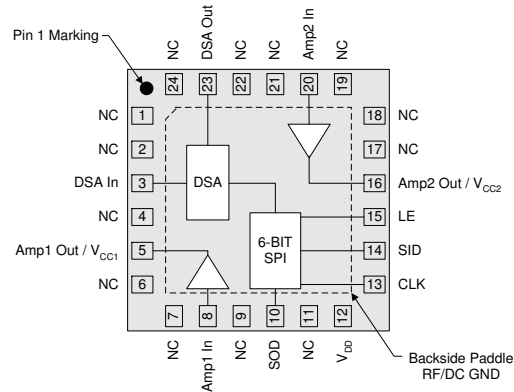

Pin No.	Symbol	Description
1, 2, 4, 6, 7, 9, 11, 17, 18, 19, 21, 22, 24	NC (No Connect)	No electrical connection. Land pads should be provided for PCB mounting integrity.
3	DSA In	DSA Input
5	Amp1 Out/V _{CC1}	RF output / DC supply (Amp1).
8	Amp1 In	RF input (Amp1). Band-specific matching circuit required.
10	SOD	Serial Output Data
12	V _{DD}	DC Supply
13	CLK	Serial Clock
14	SID	Serial Input Data
15	LE	Latch Enable
16	Amp2 Out/V _{CC2}	RF output / DC supply (Amp2). Band-specific matching
20	Amp2 In	RF input (Amp2). Band-specific matching circuit required.
23	DSA Out	DSA Output
Backside Paddle	RF/DC GND	RF/DC ground. Use recommended via pattern to minimize inductance and thermal resistance. See PCB Mounting Pattern for suggested footprint.

Evaluation Board PCB Information

TriQuint PCB 1095178 Material and Stack-up

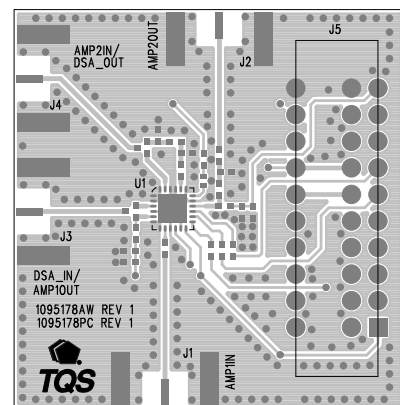
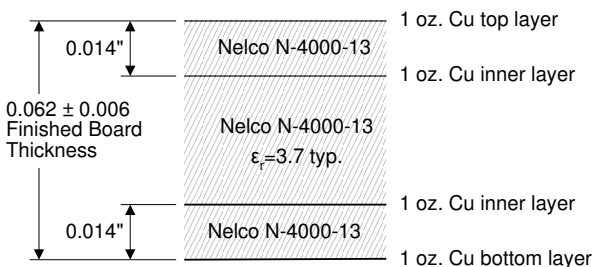

TQM879026

0.7–4 GHz 1/4W Digital Variable Gain Amplifier



Mechanical Information

Package Marking and Dimensions

Marking: Part number – TQM879026
 Year/week/country code - YYWW CCCC
 Lot code – AaXXXX

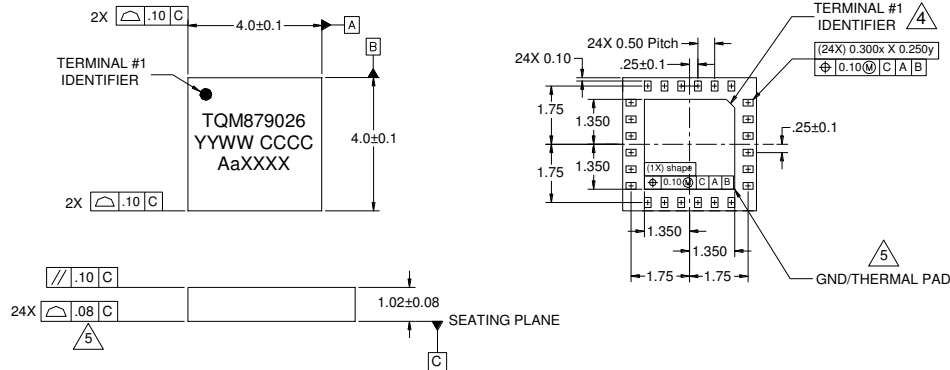

NOTES:

1. All dimensions are in millimeters. Angles are in degrees.
2. Dimension and tolerance formats conform to ASME Y14.4M-1994.
3. The terminal #1 identifier and terminal numbering conform to JESD 95-1 SPP-012.

PCB Mounting Pattern

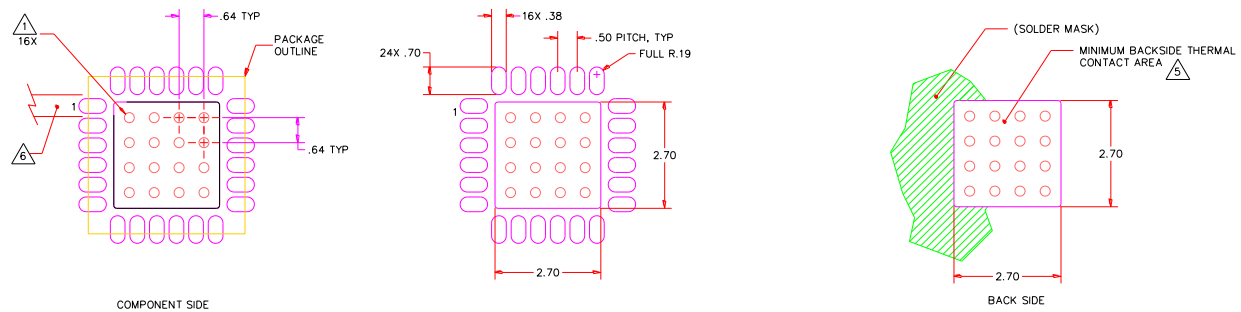

NOTES:

1. All dimensions are in millimeters. Angles are in degrees.
2. Use 1 oz. copper minimum for top and bottom layer metal.
3. Vias are required under the backside paddle of this device for proper RF/DC grounding and thermal dissipation.
4. Do not remove or minimize via hole structure in the PCB. Thermal and RF grounding is critical.
5. We recommend a 0.35mm (#80/.0135") diameter bit for drilling via holes and a final plated thru diameter of 0.25 mm (0.10").
6. Ensure good package backside paddle solder attach for reliable operation and best electrical performance.

TQM879026

0.7–4 GHz 1/4W Digital Variable Gain Amplifier



Product Compliance Information

ESD Sensitivity Ratings



Caution! ESD-Sensitive Device

ESD Rating: Class 1A
Value: Passes ≥ 250 V to < 500 V
Test: Human Body Model (HBM)
Standard: JEDEC Standard JESD22-A114

ESD Rating: Class IV
Value: Passes ≥ 1000 V
Test: Charged Device Model (CDM)
Standard: JEDEC Standard JESD22-C101

MSL Rating

MSL Rating: Level 3
Test: 260°C convection reflow
Standard: JEDEC Standard IPC/JEDEC J-STD-020

Solderability

Compatible with both lead-free (260 °C max. reflow temperature) and tin/lead (245 °C max. reflow temperature) soldering processes.

Contact plating: Electrolytic plated Au over Ni

RoHs Compliance

This part is compliant with EU 2002/95/EC RoHS directive (Restrictions on the Use of Certain Hazardous Substances in Electrical and Electronic Equipment).

This product also has the following attributes:

- Lead Free
- Halogen Free (Chlorine, Bromine)
- Antimony Free
- TBBP-A (C₁₅H₁₂Br₄O₂) Free
- PFOS Free
- SVHC Free

Contact Information

For the latest specifications, additional product information, worldwide sales and distribution locations, and information about TriQuint:

Web: www.triquint.com
Email: info-sales@tqs.com

Tel: +1.503.615.9000
Fax: +1.503.615.8902

For technical questions and application information: Email: sjapplications.engineering@tqs.com

Important Notice

The information contained herein is believed to be reliable. TriQuint makes no warranties regarding the information contained herein. TriQuint assumes no responsibility or liability whatsoever for any of the information contained herein. TriQuint assumes no responsibility or liability whatsoever for the use of the information contained herein. The information contained herein is provided "AS IS, WHERE IS" and with all faults, and the entire risk associated with such information is entirely with the user. All information contained herein is subject to change without notice. Customers should obtain and verify the latest relevant information before placing orders for TriQuint products. The information contained herein or any use of such information does not grant, explicitly or implicitly, to any party any patent rights, licenses, or any other intellectual property rights, whether with regard to such information itself or anything described by such information.

TriQuint products are not warranted or authorized for use as critical components in medical, life-saving, or life-sustaining applications, or other applications where a failure would reasonably be expected to cause severe personal injury or death.