

TQM8M9074

1/2 W High Linearity Variable Gain Amplifier



Applications

- 2G / 3G / 4G Wireless Infrastructure
- LTE / WCDMA / CDMA / EDGE
- General Purpose Wireless

Product Features

- Integrates Amp + VVA + Amp functionality
- 700-2800 MHz
- 23 dB Gain @ 2.14 GHz
- 3.4 dB Noise Figure @ max gain setting
- +27.5 dBm P1dB
- +43 dBm OIP3
- +5V Supply Voltage
- 240 mA Quiescent Current
- MTTF > 1000 Years

General Description

The TQM8M9074 is a high dynamic range analog controlled variable gain amplifier (VGA) which operates from 0.7 to 2.8 GHz. The VGA is able to achieve high performance with +43 dBm OIP3 and +27.5 dBm P1dB over a wide gain variation range while only consuming 225 mA current.

The TQM8M9074 integrates a high linearity, low noise amplifier for the first stage, followed by a broadband voltage variable attenuator, and then with a high performance 1/2W P1dB amplifier. The input and output of the various individual stages are accessible with external pins to allow for optimization of performance at any sub-band across the VGA's 0.7 to 2.8 GHz operating frequency range. The TQM8M9074 is packaged in a RoHS-compliant, compact 5x5mm surface-mount leadless package. Superior thermal design allows the product to have a minimum MTTF rating of 1000 years at a mounting temperature of +85° C.

The TQM8M9074 is targeted for use in wireless infrastructure where high linearity, medium power, and high efficiency are required.

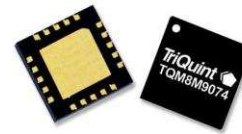

20-pin 5x5mm leadless package

Functional Block Diagram

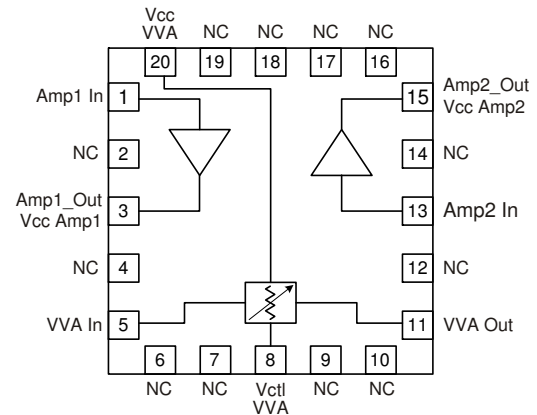

Pin Configuration

Pin #	Symbol
1	Amp1_In
2, 4, 6, 7, 9, 10, 12, 14, 16, 17, 18, 19	NC (No Connect)
3	Amp1_Out / Vcc Amp1
5	VVA_In
8	Vctrl_VVA
11	VVA_Out
13	Amp2_In
15	Amp2_Out / Vcc Amp2
20	Vcc_VVA
Backside Paddle	RF/DC Ground

Ordering Information

Part No.	Description
TQM8M9074	1/2W Variable Gain Amplifier
TQM8M9074-PCB2140	2140 MHz Eval Board

Standard T/R size = 2500 pieces on a 15" reel.

TQM8M9074

1/2 W High Linearity Variable Gain Amplifier



Specifications

Absolute Maximum Ratings

Parameter	Rating
Storage Temperature	-65 to 150 °C
RF Input Power, CW, 50Ω, T = 25°C	+10 dBm
Supply Voltage (Vcc)	+6 V

Operation of this device outside the parameter ranges given above may cause permanent damage.

Recommended Operating Conditions

Parameter	Min	Typ	Max	Units
V _{cc}	4.75	5	5.25	V
I _{cc}		240		mA
Operating Temp. Range	-40		+85	°C
T _J (for >10 ⁶ hours MTTF)			+170	°C

Electrical specifications are measured at specified test conditions. Specifications are not guaranteed over all recommended operating conditions.

Electrical Specifications

Test conditions unless otherwise noted: T_{LEAD}=+25°C, V_{CC}=+5V

Parameter	Conditions	Min	Typical	Max	Units
Operational Frequency Range		700		2800	MHz
Test Frequency			2140		MHz
Gain		21	23.2	25	dB
Gain Variation Range	See Note 1	25	30		dB
Gain Flatness	2140 +/- 60 MHz		0.5		dB
Input Return Loss			-14		dB
Output Return Loss			-15		dB
Output P1dB			+27.5		dBm
Output IP3	See Note 2		+43		dBm
Pout at -50 dBc ACLR	See Note 3		+18.6		dBm
Noise Figure	At max gain level		3.4		dB
Voltage Control Range	0V = max gain level	0		5	V
Supply Voltage			+5		V
Amplifier Current (Pin 3 plus 15)	See Notes 4 & 5	160	240	280	mA
VVA Current (Pin 8) @ minimum attenuation	See Note 6		3.6	6	mA
Thermal Resistance (jnc. to case) θ _{jc}				40	°C/W

Notes:

- The gain variation range is measured as the difference in gain with Vctrl = 5 V and Vctrl = 0 V.
- OIP3 measured with two tones at an output power of +11 dBm / tone separated by 1 MHz. The suppression on the largest IM3 product is used to calculate the OIP3 using a 2:1 rule.
- 3GPP WCDMA, 1±64DPCH, 3.84 MHz BW, PAR=10.2 dB at 0.01% Probability, single carrier.
- Amp1 current (pin 3) is typically 75 mA.
- Amp2 current (pin 15) is typically 150 mA.
- VVA typical current is 3.6 mA for min attenuation and 1.6 mA for max attenuation.

TQM8M9074

1/2 W High Linearity Variable Gain Amplifier



Reference Design 920 MHz (869-960 MHz)

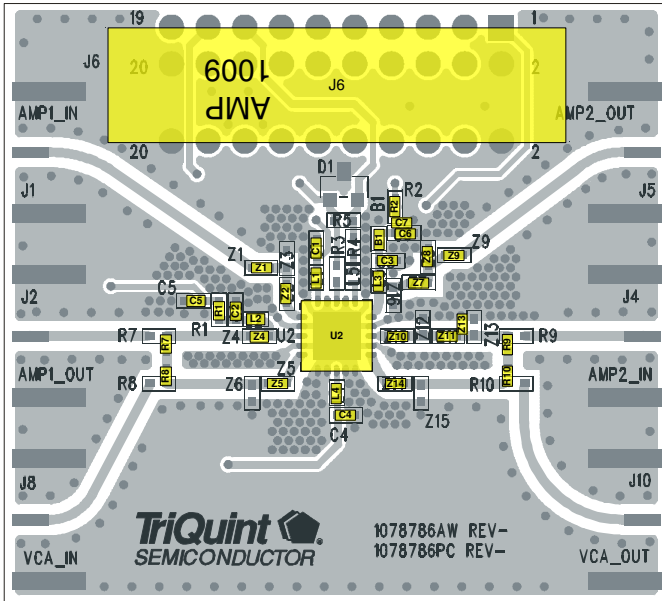

Notes:

1. PC Board Layout, page 7 for more information.
2. 0 Ohm resistors may be replaced with copper traces in the target application layout.

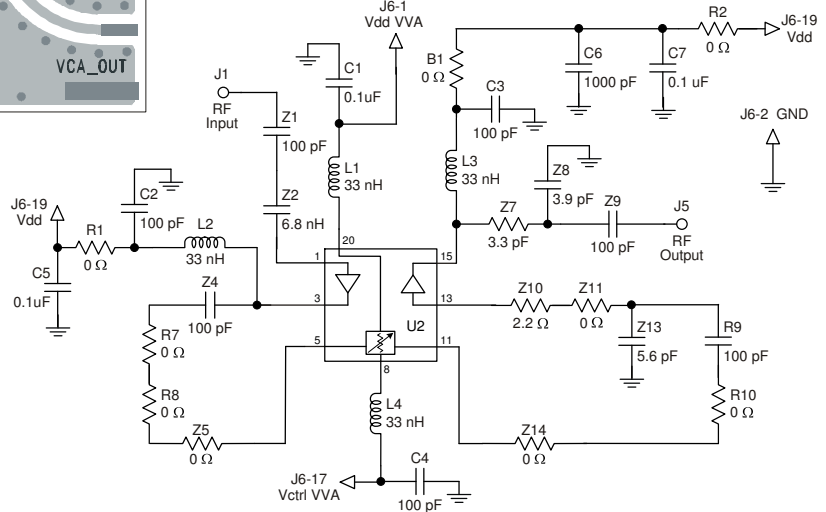

Bill of Material

Ref Des	Value	Description	Manufacturer	Part Number
U2	N/A	Variable Gain Amplifier	TriQuint	TQM8M9074
L1, L2, L3, L4	33 nH	Inductor, 0402	various	
B1, R1, R2, R7, R8, R10, Z5, Z11, Z14	0 Ohm	Resistor, 0402	various	
C1, C5, C7	0.1 uF	Capacitor, 0402	various	
C2, C3, C4, Z1, Z4, Z9, R9	100 pF	Capacitor, 0402	various	
C6	1000 pF	Capacitor, 0402	various	
Z2	6.8 nH	Inductor, 0402	various	
Z7	3.3 pF	Capacitor, 0603	various	
Z8	3.9 pF	Capacitor, 0402	various	
Z10	2.2 Ohm	Resistor, 0402	various	
Z13	5.6 pF	Capacitor, 0402	various	

TQM8M9074

1/2 W High Linearity Variable Gain Amplifier



Typical Performance 869-960 MHz

Test Conditions: Vcc=+5 V, Temp=+25°C

Frequency	MHz	869	920	960
Gain	dB	29.2	28.9	28.6
Input Return Loss	dB	-18.9	-19.4	-19.2
Output Return Loss	dB	-14.2	-13.2	-12.8
Output P1dB	dBm	+27.2	+27.5	+27.8
Output IP3 (Pout=+16 dBm per tone)	dBm	+42.5	+44.5	+47.0
Pout at -50 dBc ACLR (Single carrier, 10.2 PAR)	dBm	+18.4	+19.0	+19.3
Quiescent Current	mA	240		
Supply Voltage	V	+5		

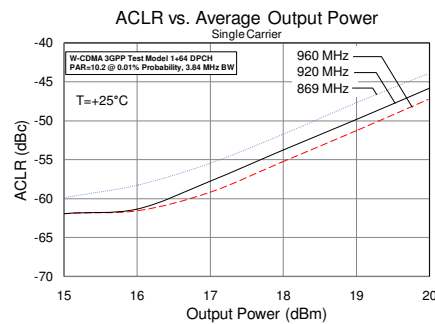
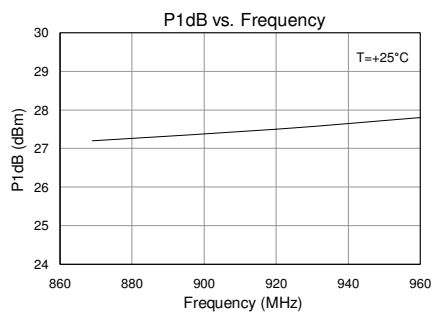
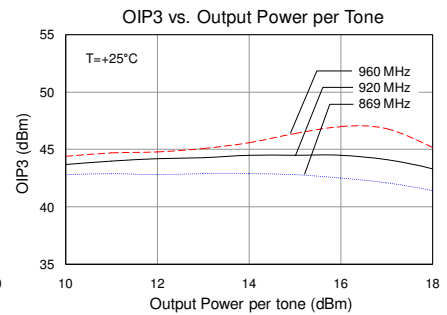
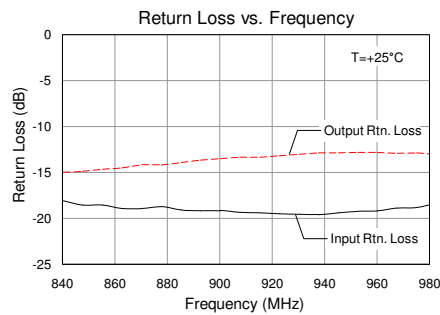
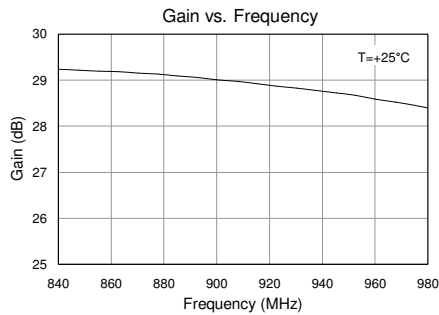

TQM8M9074

1/2 W High Linearity Variable Gain Amplifier



TQM8M9074-PCB2140 (2110-2170 MHz)

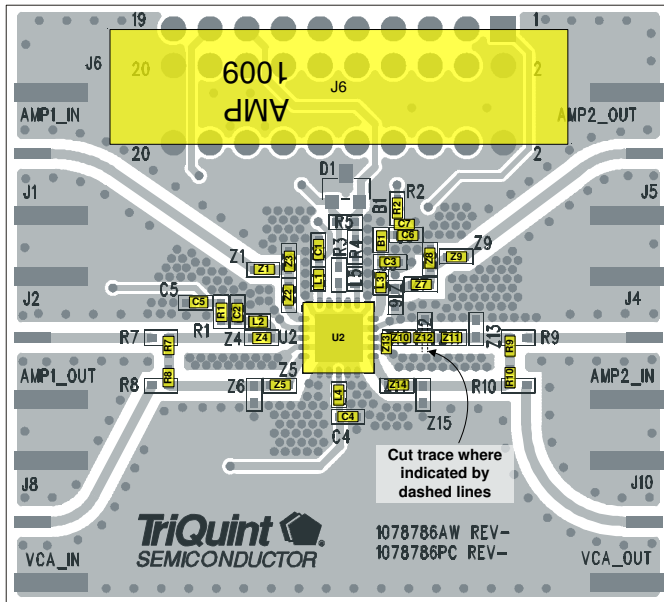

Notes:

1. PC Board Layout, page 7 for more information.
2. 0 Ohm resistors may be replaced with copper traces in the target application layout.

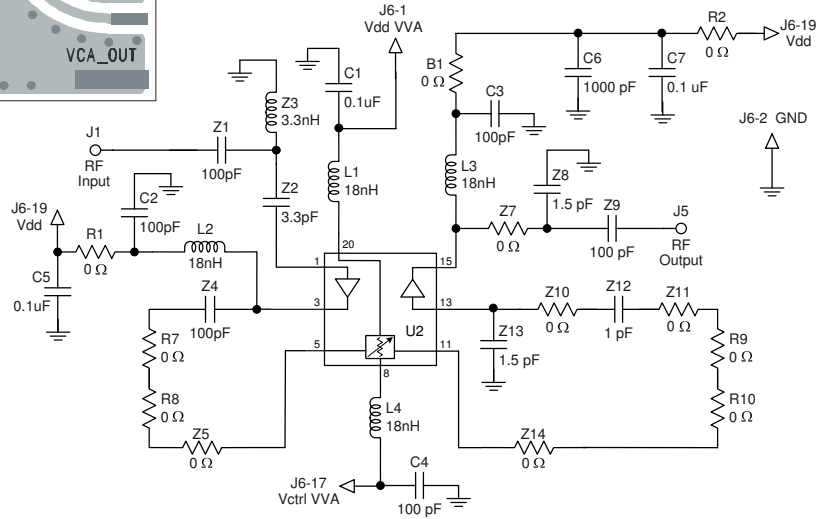

Bill of Material

Ref Des	Value	Description	Manufacturer	Part Number
U2	N/A	Variable Gain Amplifier	TriQuint	TQM8M9074
L1, L2, L3, L4	18 nH	Inductor, 0402	various	
Z3	3.3 nH	Inductor, 0402	various	
B1, R1, R2, R7, R8, R9, R10, Z5, Z7, Z10, Z11, Z14	0 Ohm	Resistor, 0402, jumper	various	
C1, C5, C7	0.1 uF	Capacitor, 0402	various	
C2, C3, C4, Z1, Z4, Z9	100 pF	Capacitor, 0402	various	
C6	1000 pF	Capacitor, 0402	various	
Z2	3.3 pF	Capacitor, 0402	various	
Z8	1.5 pF	Capacitor, 0402	various	
Z12	1.0 pF	Capacitor, 0402	various	
Z13	1.5 pF	Capacitor, 0402	various	

TQM8M9074

1/2 W High Linearity Variable Gain Amplifier



Typical Performance 2110-2170 MHz

Test Conditions: Vcc=+5 V, Temp=+25°C

Frequency	MHz	2110	2140	2170
Gain	dB	23.6	23.2	23.0
Input Return Loss	dB	-15.3	-15.6	-15.7
Output Return Loss	dB	-16.6	-16.5	-16.7
Output P1dB	dBm	+28.0	+27.5	+27.4
Output IP3 (Pout=+11 dBm per tone)	dBm	+43.6	+42.9	+42.5
Pout at -50 dBc ACLR (Single carrier, 10.2 PAR)	dBm	+18.8	+18.6	+18.5
Amplifier Current	mA	240		
Supply Voltage	V	+5		

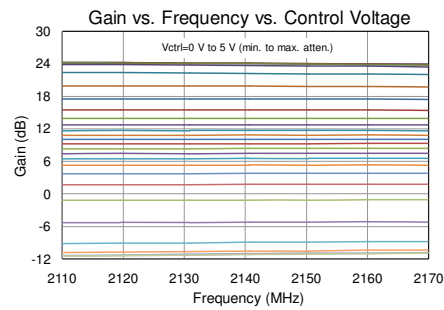
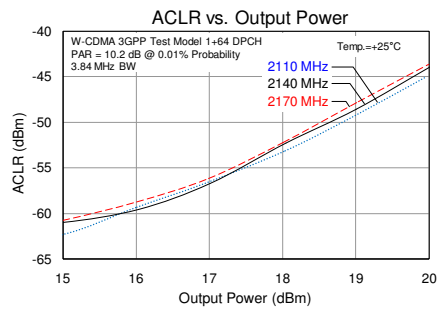
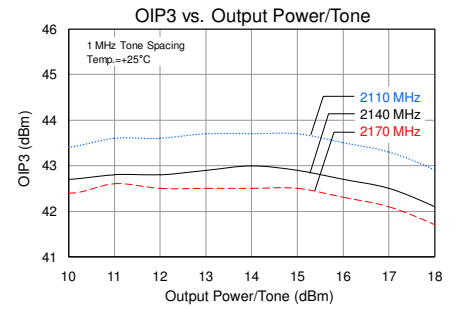
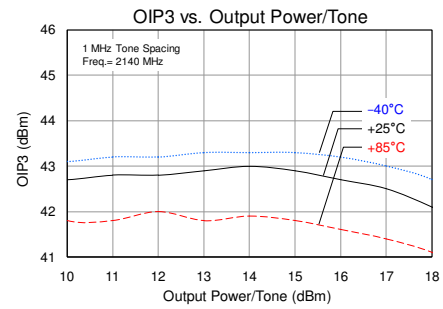
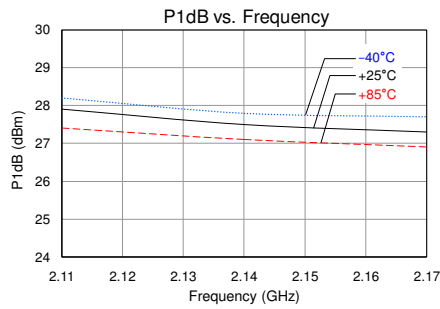
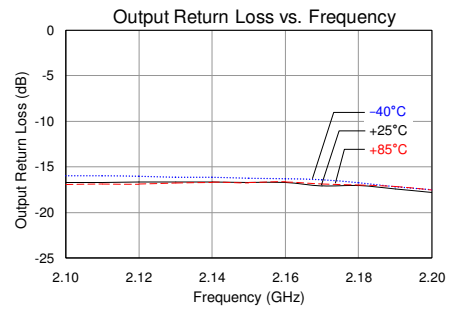
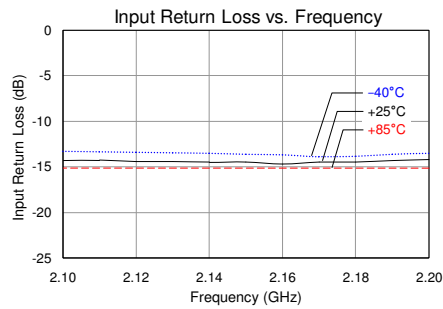
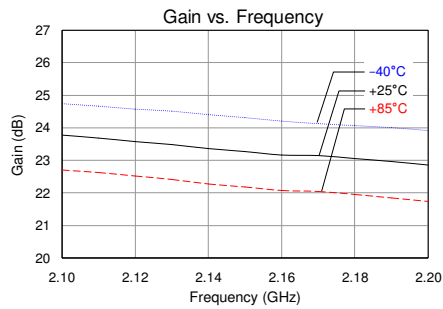

TQM8M9074

1/2 W High Linearity Variable Gain Amplifier



Pin Description

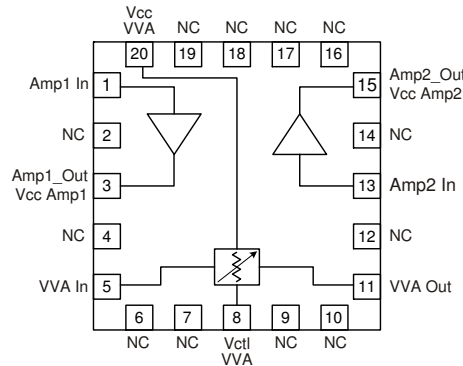

Pin #	Symbol	Description
1	Amp1_In	RF input (Amp1). Band-specific matching circuit required.
2, 4, 6, 7, 9, 10, 12, 14, 16, 17, 18, 19	NC (No Connect)	No electrical connection. Land pads should be provided for PCB mounting integrity.
3	Amp1_Out/Vcc Amp1	RF output / DC supply (Amp1).
5	VVA_In	RF input (VVA).
8	Vctrl_VVA	Analog input for voltage controlled amplifier.
11	VVA_Out	RF output (VVA).
13	Amp2_In	RF input (Amp2). Band-specific matching circuit required.
15	Amp2_Out/Vcc Amp2	RF output / DC supply (Amp2). Band-specific matching circuit required.
20	Vcc_VVA	DC supply for voltage controlled amplifier.
Backside Paddle	RF/DC Ground	RF/DC ground. Provide recommended via pattern (see page 8) and ensure good solder attach for best thermal and electrical performance.

Applications Information

PC Board Layout

PCB Material (stackup):

- 1/2oz. Cu top layer
- 0.014 inch Nelco N-4000-13
- 1/2oz. Cu MIDDLE layer 1
- Core Nelco N-4000-13
- 1/2 Cu middle layer 2
- 0.014 inch Nelco N-4000-13
- 1/2oz. Cu bottom layer
- Finished board thickness is 0.062±.006

The pad pattern shown has been developed and tested for optimized assembly at TriQuint Semiconductor. The PCB land pattern has been developed to accommodate lead and package tolerances. Since surface mount processes vary from company to company, careful process development is recommended.

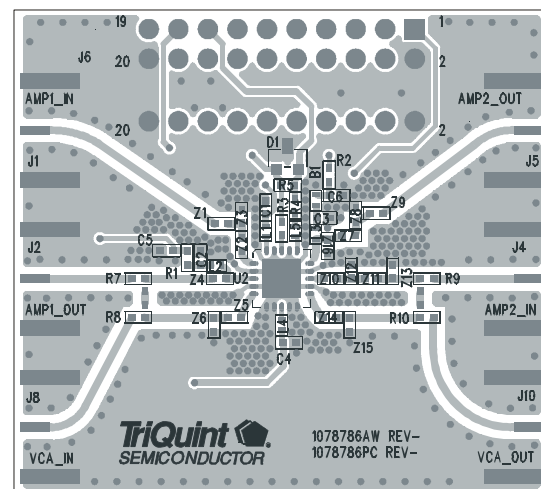

TQM8M9074

1/2 W High Linearity Variable Gain Amplifier



Mechanical Information

Package Information & Dimensions

Material:

RoHS-compliant

Contact plating: Electrolytic plated Au over Ni

Package Marking:

Part number - TQM8M9074

Year, week, country code - YYWW CCCC

Assembly code - AaXXXX

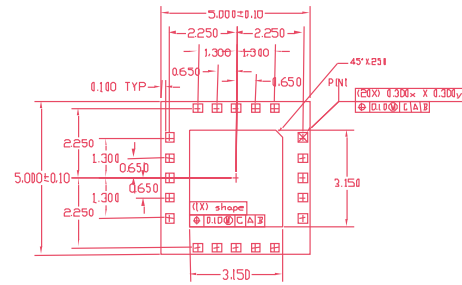

BOTTOM VIEW

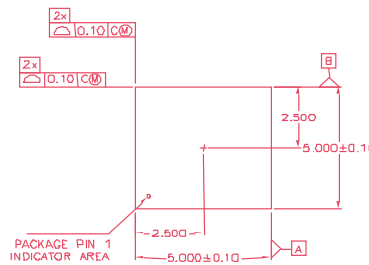

TOP VIEW

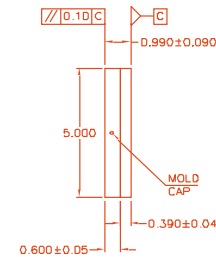

SIDE VIEW

Mounting Configuration

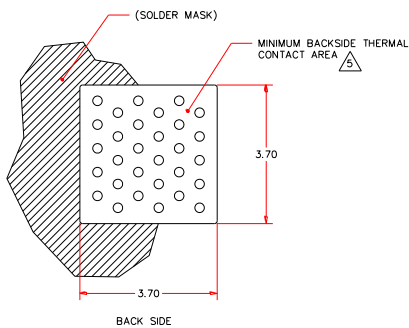
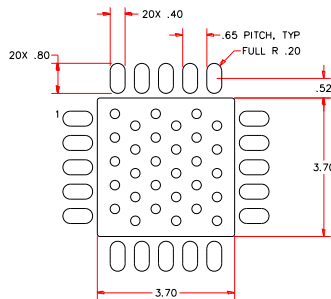
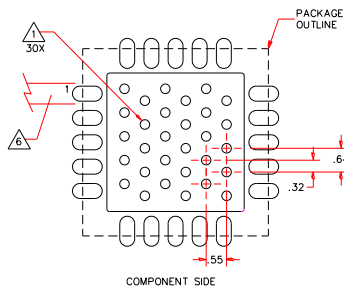

NOTES:

1. GROUND/THERMAL VIAS ARE CRITICAL FOR THE PROPER PERFORMANCE OF THIS DEVICE. VIAS SHOULD USE A .35mm (#80/.0125") DIAMETER DRILL AND HAVE A FINAL, PLATED THRU DIAMETER OF .25mm (.010").
2. ADD AS MUCH COPPER AS POSSIBLE TO INNER AND OUTER LAYERS NEAR THE PART TO ENSURE OPTIMAL THERMAL PERFORMANCE.
3. TO ENSURE RELIABLE OPERATION, DEVICE GROUND PADDLE-TO-GROUND PAD SOLDER JOINT IS CRITICAL.
4. ADD MOUNTING SCREWS NEAR THE PART TO FASTEN THE BOARD TO A HEATSINK. ENSURE THAT THE GROUND/THERMAL VIA REGION CONTACTS THE HEATSINK.
5. DO NOT PUT SOLDER MASK ON THE BACK SIDE OF THE PC BOARD IN THE REGION WHERE THE BOARD CONTACTS THE HEATSINK.
6. RF TRACE WIDTH DEPENDS UPON THE PC BOARD MATERIAL AND CONSTRUCTION.
7. USE 1 OZ. COPPER MINIMUM.
8. ALL DIMENSIONS ARE IN MILLIMETERS. ANGLES ARE IN DEGREES.

TQM8M9074

1/2 W High Linearity Variable Gain Amplifier



Product Compliance Information

ESD Information



Caution! ESD-Sensitive Device

Solderability

Compatible with both J-STD-020 lead-free (maximum 260 °C reflow temperature) and lead (maximum 245 °C reflow temperature) soldering processes.

This part is compliant with EU 2002/95/EC RoHS directive (Restrictions on the Use of Certain Hazardous Substances in Electrical and Electronic Equipment).

This product also has the following attributes:

- Halogen Free (Chlorine, Bromine)
- Antimony Free
- TBBP-A (C₁₅H₁₂Br₄O₂) Free
- PFOS Free
- SVHC Free

MSL Rating

Level 3 at +260 °C convection reflow per JEDEC standard IPC/JEDEC J-STD-020.

Contact Information

For the latest specifications, additional product information, worldwide sales and distribution locations, and information about TriQuint:

Web: www.triquint.com
Email: info-sales@tqs.com

Tel: +1.503.615.9000
Fax: +1.503.615.8902

For technical questions and application information:

Email: sjapplications.engineering@tqs.com

Important Notice

The information contained herein is believed to be reliable. TriQuint makes no warranties regarding the information contained herein. TriQuint assumes no responsibility or liability whatsoever for any of the information contained herein. TriQuint assumes no responsibility or liability whatsoever for the use of the information contained herein. The information contained herein is provided "AS IS, WHERE IS" and with all faults, and the entire risk associated with such information is entirely with the user. All information contained herein is subject to change without notice. Customers should obtain and verify the latest relevant information before placing orders for TriQuint products. The information contained herein or any use of such information does not grant, explicitly or implicitly, to any party any patent rights, licenses, or any other intellectual property rights, whether with regard to such information itself or anything described by such information.

TriQuint products are not warranted or authorized for use as critical components in medical, life-saving, or life-sustaining applications, or other applications where a failure would reasonably be expected to cause severe personal injury or death.