

# TQM8M9079

## 500–2700 MHz Variable Gain Amplifier

### Applications

- Wireless Infrastructure
- LTE / WCDMA / CDMA / EDGE
- PtP IF Gain Control
- General Purpose Wireless

### Product Features

- Integrates Amp + VVA + Amp functionality
- 500–2700 MHz Bandwidth
- 38 dB Gain (max gain setting)
- 4.0 dB Noise Figure
- +16 dBm P1dB
- +29 dBm OIP3
- +5V Supply Voltage
- Low Current

### General Description

The TQM8M9079 is an analog controlled variable gain amplifier (VGA) which operates from 500 to 2700 MHz. The VGA is able to provide broadband performance with +29 dBm OIP3 and +16 dBm P1dB over a wide frequency range while only consuming 95 mA current.

The TQM8M9079 integrates two broadband gain blocks with a voltage variable attenuator. The three stages are individually accessible via package I/O contacts. This permits full flexibility to insert other components or filters between the stages.

The TQM8M9079 is packaged in a RoHS-compliant, compact 5x5 mm surface-mount leadless package. Superior thermal design allows the product to have a minimum MTTF rating of 1000 years at a mounting temperature of +85° C.

The TQM8M9079 is targeted for use in wireless infrastructure, IF gain control in point-to-point applications, and for general purpose wireless.

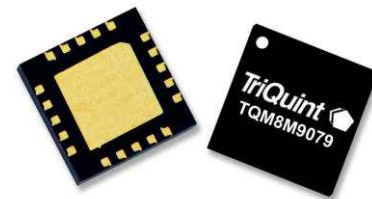

20-pin 5x5 mm Leadless Package

### Functional Block Diagram

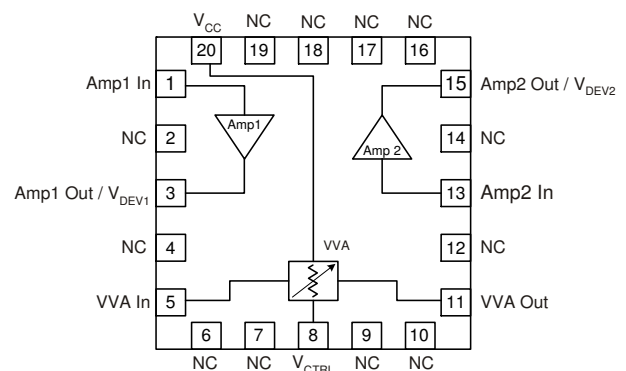

### Pin Configuration

Pin No.	Symbol
1	Amp1 In
2, 4, 6, 7, 9, 10, 12, 14, 16, 17, 18, 19	NC (No Connect)
3	Amp1 Out / V <sub>DEV1</sub>
5	VVA In
8	Vctrl
11	VVA Out
13	Amp2 In
15	Amp2 Out / V <sub>DEV2</sub>
20	Vcc
Backside Paddle	GND

### Ordering Information

Part No.	Description
TQM8M9079	Variable Gain Amplifier
TQM8M9079-PCB	500–2500 MHz Evaluation Board

Standard T/R size = 2500 pieces on a 13" reel

# TQM8M9079

## 500–2700 MHz Variable Gain Amplifier



### Absolute Maximum Ratings

Parameter	Rating
Storage Temperature	-65 to 150 °C
RF Input Power, CW, 50Ω, T = 25 °C	+24 dBm
Amplifier Voltage ( $V_{DEV1,2}$ )	+4.5 V
Control Voltage ( $V_{CTRL}$ )	+6 V

Operation of this device outside the parameter ranges given above may cause permanent damage.

### Recommended Operating Conditions

Parameter	Min	Typ	Max	Units
Control Voltage ( $V_{CTRL}$ )	0.5		5	V
Operating Temp. Range	-40		+85	°C
$T_J$ (for $>10^6$ hours MTTF)			170	°C

Electrical specifications are measured under test conditions as described or noted. Electrical specifications are not guaranteed over all recommended operating conditions.

### Electrical Specifications

Test conditions unless otherwise noted:  $V_{CC}=+5V$ ,  $R_{BIAS}=24\Omega$ , Maximum gain setting, Temp.=+25 °C

Parameter	Conditions	Min	Typ	Max	Units
Operational Frequency Range		500		2700	MHz
Test Frequency			2140		MHz
Gain			38		dB
Gain Variation Range	Note 1		30		dB
Input Return Loss			11		dB
Output Return Loss			20		dB
Output IP3	$P_{out}=0$ dBm/tone, $\Delta f=1$ MHz		+29		dBm
Output P1dB			+16		dBm
Noise Figure			4.0		dB
Amplifier Current	Note 2		95		mA
VVA Current (Pin 8)	Note 3		3.9		mA
Thermal Resistance, $\Theta_{JC}$	Junction to case			61	°C/W

Notes:

1. The Gain variation range is measured as the difference in gain with  $V_{ctrl} = 5$  V and  $V_{ctrl} = 0$  V.
2. Amp1 current (pin 3) and Amp2 current (pin 15) are typically 47.5 mA in each
3. VVA typical current is  $< 1$  mA for min attenuation and 3.9 mA for max attenuation

# TQM8M9079

500–2700 MHz Variable Gain Amplifier



## Application Circuit TQM8M9079-PCB

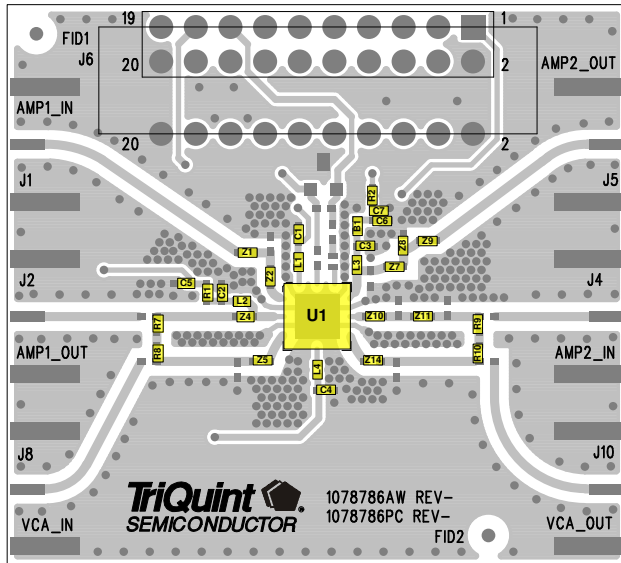

Notes:

1. See Evaluation Board PCB Information section for material and stack-up.
2. 0 Ω jumpers are not shown on the schematic and may be replaced with copper trace in the target application layout.

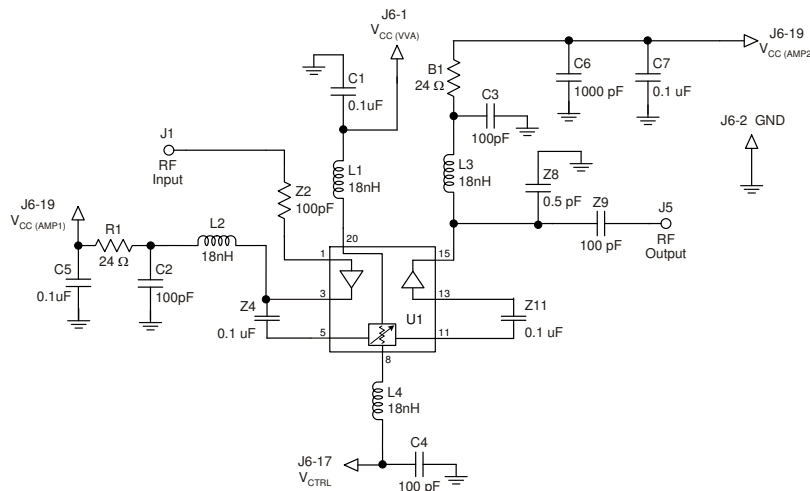

## Bill of Material TQM8M9079-PCB

Reference Des.	Value	Description	Manuf.	Part Number
N/A	N/A	Printed Circuit Board	TriQuint	1078786
U1	n/a	Variable Gain Amplifier	TriQuint	TQM8M9079
B1, R1 (RBIAS)	24 Ω	Res., Chip, 0402, 5%, 1/16W	various	
L1, L2, L3, L4	18 nH	Inductor, 0402, 5%, 3.1 GHz SRF	CoilCraft	0402CS-18NXJL
R2, R7, R8, R9, R10, Z1, Z5, Z7, Z10, Z14	0 Ω	Res., Chip, 0402, 5%, 1/16W	various	
C1, C5, C7, Z4, Z11	0.1 uF	Res., Chip, 0402, 5%, 1/16W	various	
C2, C3, C4, Z2, Z9	100 pF	Cap., Chip, 0402, 5%, 50V, NPO/COG	various	
C6	1000 pF	Cap., Chip, 0402, 10%, 50V, X5R	various	
Z8	0.5 pF	Cap., Chip, 0402, 5%, 50V, NPO/COG	various	

# TQM8M9079

## 500–2700 MHz Variable Gain Amplifier



### Typical Performance TQM8M9079-PCB

Test conditions unless otherwise noted:  $V_{CC} = +5\text{ V}$ ,  $R_{BIAS}=24\Omega$ , Maximum Gain Setting, Temp= $25^{\circ}\text{C}$

Parameter	Typical Value					Units
Frequency	500	900	1900	2140	2700	MHz
Gain	39.6	39.8	37.9	38.0	32.6	dB
Input Return Loss	9.1	11.0	16.7	11.2	9.6	dB
Output Return Loss	5.1	8.0	19.7	20.2	11.2	dB
Output IP3 (note 1)	+30.3	+30.4	+29.4	+29.1	+28.9	dBm
Output P1dB	+15.8	+15.9	+15.7	+15.7	+14.9	dBm
Noise Figure (note 2)	4.0	3.9	4.0	4.1	4.3	dB

Notes:

- IIP3 measured with two tones at an input power of +0 dBm / tone separated by 1 MHz.
- Evaluation board PCB losses de-embedded.

### Performance Plots TQM8M9079-PCB

Test conditions unless otherwise noted:  $V_{CC} = +5\text{ V}$ ,  $R_{BIAS}=24\Omega$ , Maximum Gain Setting, 50  $\Omega$  system.

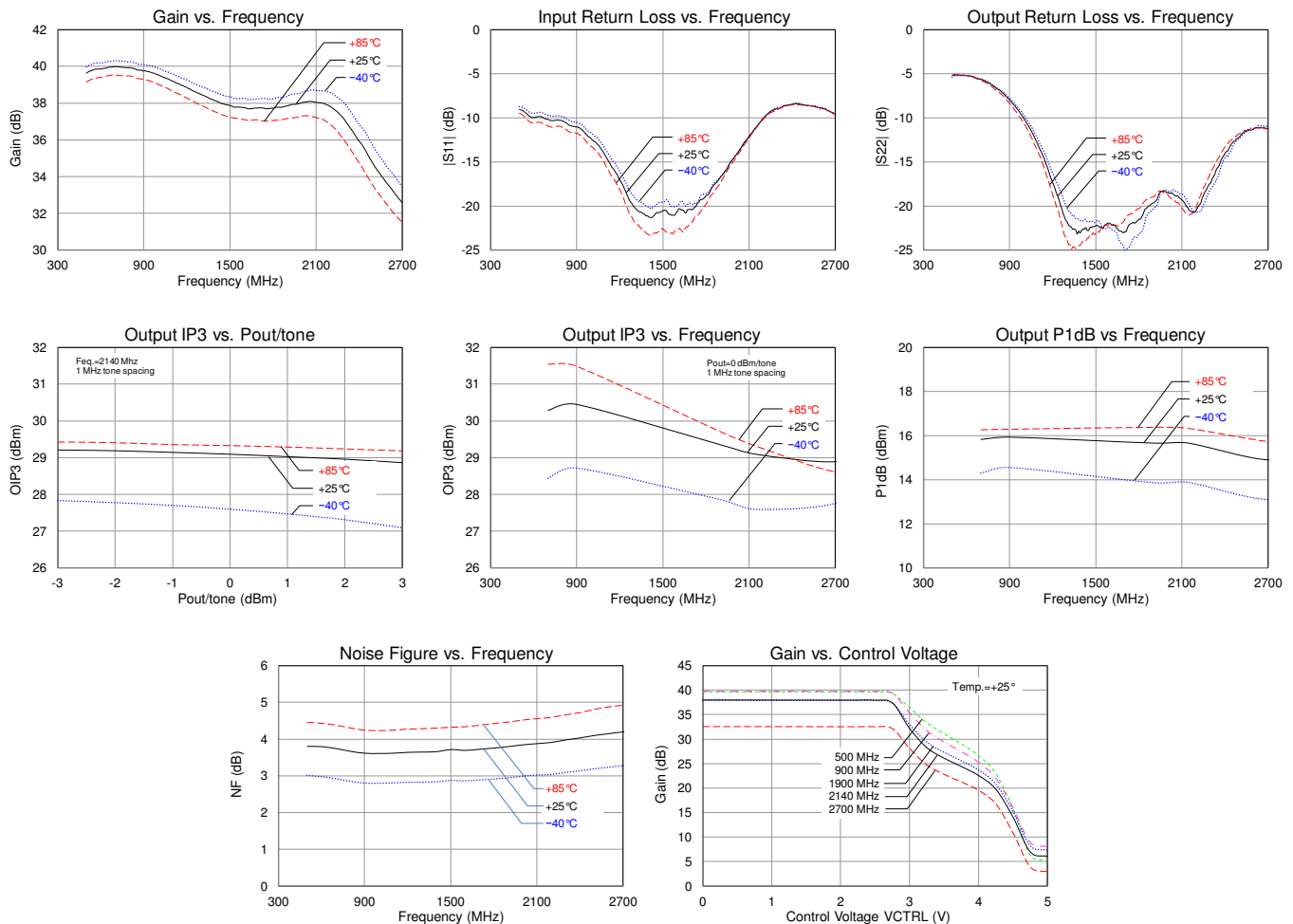

# TQM8M9079

500–2700 MHz Variable Gain Amplifier



## Pin Configuration and Description

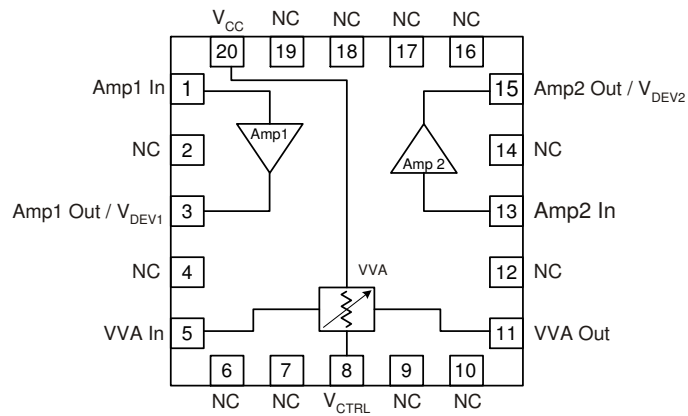

Pin No.	Symbol	Description
1	Amp1 In	RF input (Amp1). DC blocking capacitor required.
2, 4, 6, 7, 9, 10, 12, 14, 16, 17, 18, 19	NC (No Connect)	No electrical connection. Land pads should be provided for PCB mounting integrity.
3	Amp1 Out/V <sub>DEV1</sub>	RF output / DC bias (Amp1), Bias resistor required (R <sub>BIAS</sub> )
5	VVA In	RF input (VVA). DC blocking capacitor required.
8	V <sub>CTRL</sub>	Analog input for voltage controlled amplifier
11	VVA Out	RF output (VVA). DC blocking capacitor required.
13	Amp2 In	RF input (Amp2). DC blocking capacitor required.
15	Amp2 Out/V <sub>DEV2</sub>	RF output / DC bias (Amp2), Bias resistor required (R <sub>BIAS</sub> )
20	V <sub>CC</sub>	DC supply for voltage variable attenuator.
Backside Paddle	RF/DC GND	RF/DC Ground. Follow recommended via pattern and ensure good solder attach for best thermal and electrical performance.

## Evaluation Board PCB Information

TriQuint PCB 1078786 Material and Stack-up

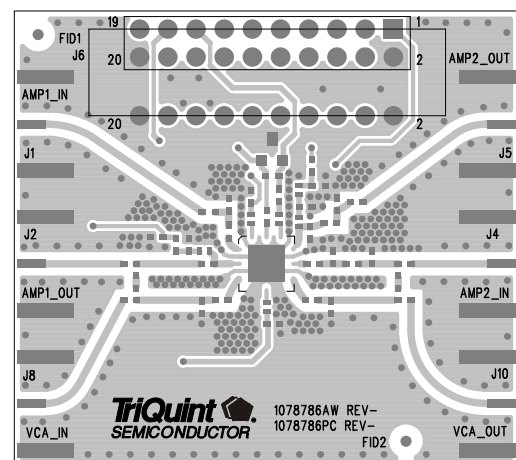
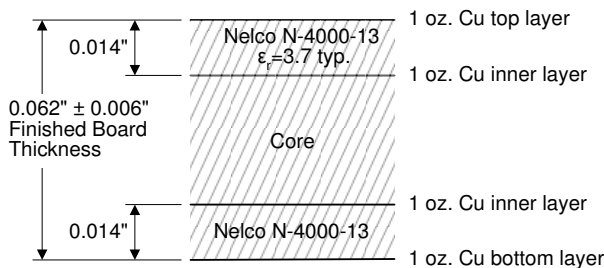

# TQM8M9079

## 500–2700 MHz Variable Gain Amplifier



### Mechanical Information

#### Package Marking and Dimensions

Marking: Part number – TQM8M9079  
 Year, week, country code – YYWW CCCC  
 Assembly code – AaXXXX

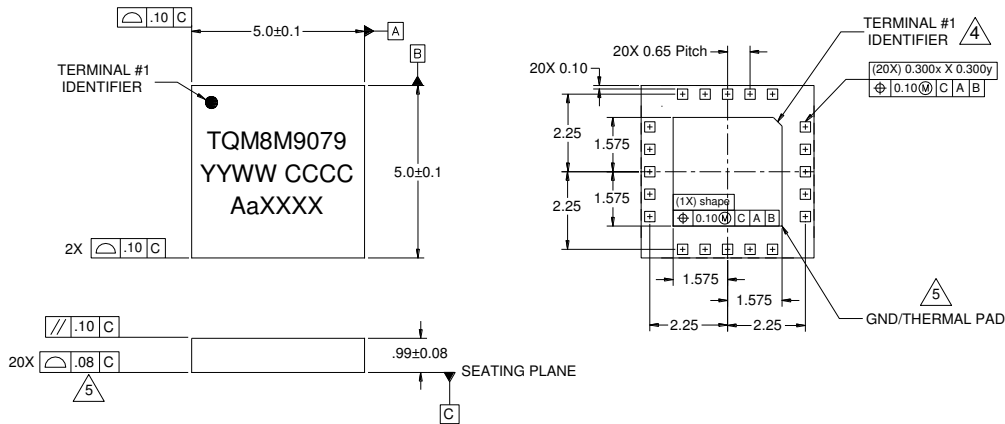

#### Notes:

1. All dimensions are in millimeters. Angles are in degrees.
2. Except where noted, this part outline conforms to JEDEC standard MO-270, Issue B (Variation DAE) for extra thin profile, fine pitch, internal stacking module (ISM).
3. Dimension and tolerance formats conform to ASME Y14.4M-1994.
4. The terminal #1 identifier and terminal numbering conform to JESD 95-1 SPP-012.
5. Co-planarity applies to the exposed ground/thermal pad as well as the contact pins.

### PCB Mounting Pattern

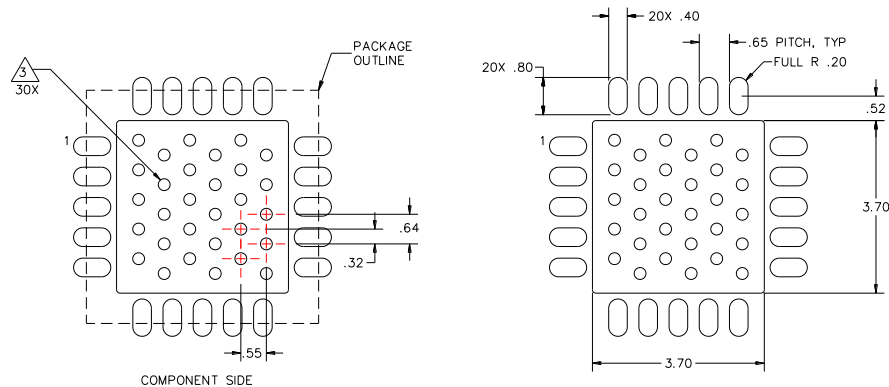

#### Notes:

1. All dimensions are in millimeters. Angles are in degrees.
2. Use 1 oz. copper minimum for top and bottom layer metal.
3. We recommend a 0.35mm (#80/.0135") diameter bit for drilling via holes and a final plated thru diameter of 0.25 mm (0.10").
4. Ensure good package backside paddle solder attach for reliable operation and best electrical performance.

# TQM8M9079

500–2700 MHz Variable Gain Amplifier

## Product Compliance Information

### ESD Sensitivity Ratings



**Caution! ESD-Sensitive Device**

ESD Rating: Class 1B  
Value:  $\geq 500$  V to  $< 1000$  V  
Test: Human Body Model (HBM)  
Standard: JEDEC Standard JESD22-A114

ESD Rating: Class IV  
Value:  $> 1000$  V  
Test: Charged Device Model (CDM)  
Standard: JEDEC Standard JESD22-C101

### MSL Rating

MSL Rating: Level 3  
Test: 260°C convection reflow  
Standard: JEDEC Standard IPC/JEDEC J-STD-020

### Solderability

Compatible with both lead-free (260°C max. reflow temperature) and tin/lead (245°C max. reflow temperature) soldering processes.

Package contact plating: Electrolytic plated Au over Ni

### RoHs Compliance

This part is compliant with EU 2002/95/EC RoHS directive (Restrictions on the Use of Certain Hazardous Substances in Electrical and Electronic Equipment).

This product also has the following attributes:

- Halogen Free (Chlorine, Bromine)
- Antimony Free
- TBBP-A ( $C_{15}H_{12}Br_4O_2$ ) Free
- PFOS Free
- SVHC Free

## Contact Information

For the latest specifications, additional product information, worldwide sales and distribution locations, and information about TriQuint:

Web: [www.triquint.com](http://www.triquint.com)  
Email: [info-sales@tqs.com](mailto:info-sales@tqs.com)

Tel: +1.503.615.9000  
Fax: +1.503.615.8902

For technical questions and application information: Email: [sjapplications.engineering@tqs.com](mailto:sjapplications.engineering@tqs.com)

## Important Notice

The information contained herein is believed to be reliable. TriQuint makes no warranties regarding the information contained herein. TriQuint assumes no responsibility or liability whatsoever for any of the information contained herein. TriQuint assumes no responsibility or liability whatsoever for the use of the information contained herein. The information contained herein is provided "AS IS, WHERE IS" and with all faults, and the entire risk associated with such information is entirely with the user. All information contained herein is subject to change without notice. Customers should obtain and verify the latest relevant information before placing orders for TriQuint products. The information contained herein or any use of such information does not grant, explicitly or implicitly, to any party any patent rights, licenses, or any other intellectual property rights, whether with regard to such information itself or anything described by such information.

TriQuint products are not warranted or authorized for use as critical components in medical, life-saving, or life-sustaining applications, or other applications where a failure would reasonably be expected to cause severe personal injury or death.