

Features

- 5 - 45 GHz frequency range
- 2 dB typical insertion loss
- >30 dB attenuation range
- High linearity, 30 dBm IIP3
- Lead-Free 3 mm, 16-Lead QFN Package
- RoHS* Compliant and 260°C Reflow Compatible

Description

The MAAT-010521 is a voltage variable attenuator with analog control and up to 40 dB of attenuation. Excellent linearity is maintained over the full attenuation range. The attenuation level is set by two control voltages of 0 to -2V.

The 3mm QFN package is RoHS compliant and compatible with reflow temperatures to 260°C. Applications include transceivers for cellular infrastructure.

Functional Block Diagram

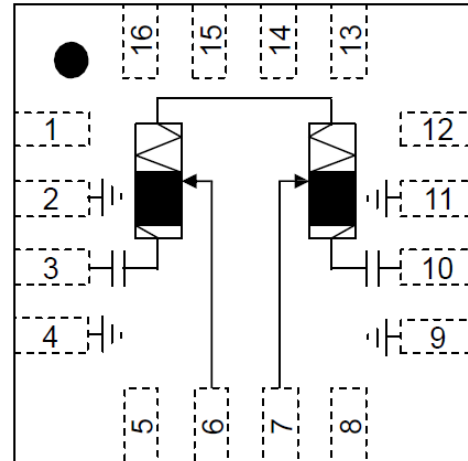

Pin Configuration^{3,4}

Pin No.	Function
1	No Connection
2	Ground
3	RF Input
4	Ground
5	No Connection
6	VC1
7	VC2
8	No Connection
9	Ground
10	RF Output
11	Ground
12	No Connection
13	No Connection
14	No Connection
15	No Connection
16	No Connection

Ordering Information^{1,2}

Part Number	Package
MAAT-010521-TR0500	500 piece reel
MAAT-010521-TR3000	3000 piece reel
MAAT-010521 -001SMB	Sample Test Board

1. Reference Application Note M513 for reel size information.
2. All sample boards include 5 loose parts.

3. It is recommended to connect unused pins to ground.
4. The exposed pad centered on the package bottom must be connected to RF and DC ground.

* Restrictions on Hazardous Substances,
European Union Directive 2002/95/EC.

Electrical Specifications: $T_A = +25^\circ\text{C}$, $Z_0 = 50 \Omega$, $\text{Pin} = -10 \text{ dBm}$

Parameter	Test Conditions	Units	Min.	Typ.	Max.
Insertion Loss (V_{c1} and $V_{c2} = -2.0\text{V}$)	10 GHz	dB	-	2	4
	20 GHz		-	2	4
	40 GHz		-	3	6
Attenuation (V_{c1} and $V_{c2} = 0\text{V}$) ⁵	10 GHz	dB	26	30	-
	20 GHz		34	40	-
	40 GHz		34	40	-
Input P1dB	5 GHz to 25 GHz	dBm	—	25	—
	25 GHz to 40 GHz			22	
IIP3 (any attenuation)	$\text{Pin}=10 \text{ dB/tone}$	dBm	—	30	—
Input Return Loss (any attenuation)		dB	—	10	—
Output Return Loss (any attenuation)		dB	—	10	—

5. To increase attenuation from min. attenuation state ($V_{C1} = -2\text{V}$ and $V_{C2} = -2\text{V}$) to max attenuation state ($V_{C1} = 0\text{V}$ and $V_{C2} = 0\text{V}$), V_{C1} increases to full range prior to adjusting V_{C2} .

Absolute Maximum Ratings^{6,7}

Parameter	Absolute Maximum
Input Power	+30 dBm
Voltage (RF pins)	30 volts
Voltage (control pins)	+1 to -6 volts
Storage Temperature	-55°C to +150°C
Case Temperature	-40°C to +85°C

6. Exceeding any one or combination of these limits may cause permanent damage to this device.
7. M/A-COM Technology does not recommend sustained operation near these survivability limits.

Operating at high levels of attenuation:

The MAAT-010521 is a two stage attenuator, with each stage consisting of a sequence of shunt FETs distributed along a transmission line. As the FETs are turned on, that is, as the control voltage increases towards zero volts, the attenuation between RF input and RF output increases. However, as the shunt FET channels are opened, they become more sensitive to voltage swings induced by the RF signal itself, and it is possible that the attenuation level will vary as the signal power increases. The second stage, which handles large levels of attenuation, is sensitive to this effect. Therefore, should operation with V_{C2} in the range -0.7 to 0 V be considered, it is recommended that care be taken to verify that the attenuation level and signal power range are compatible with the intended operating range of the attenuator.

Voltage Variable Attenuator 5 - 45 GHz

Rev. V1

Typical Performance Curves: S-Parameters

Gain

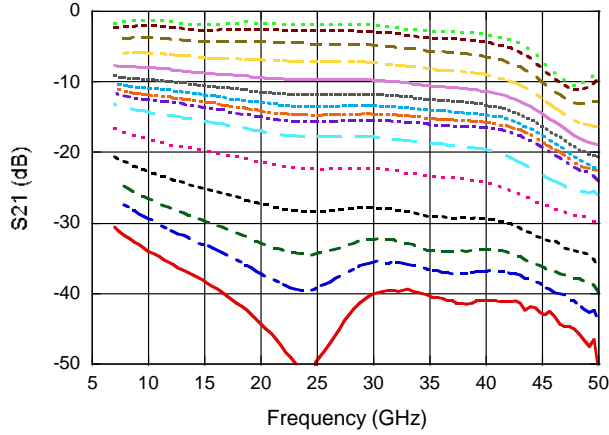

Input Return Loss

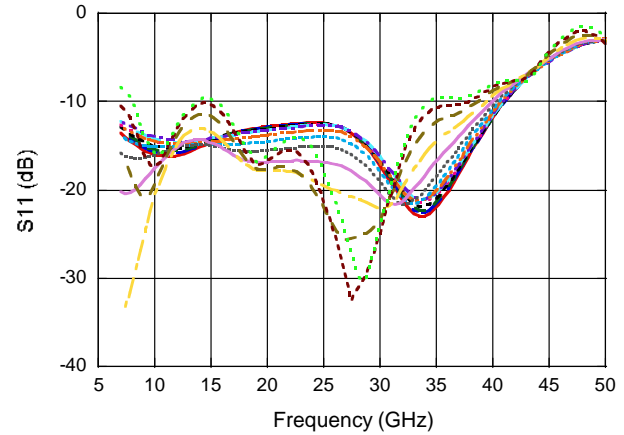

Output Return Loss

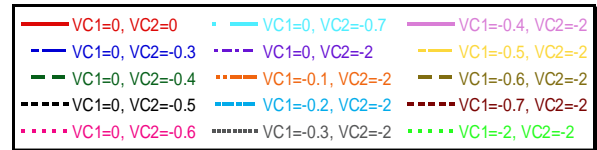
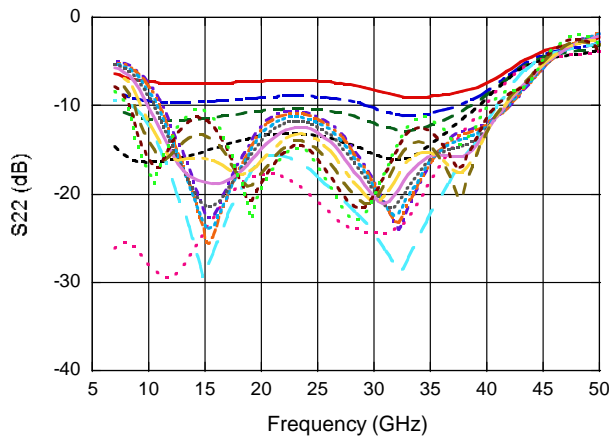

Typical Performance Curves: S-Parameters

VC1 = -2, VC2 = -2

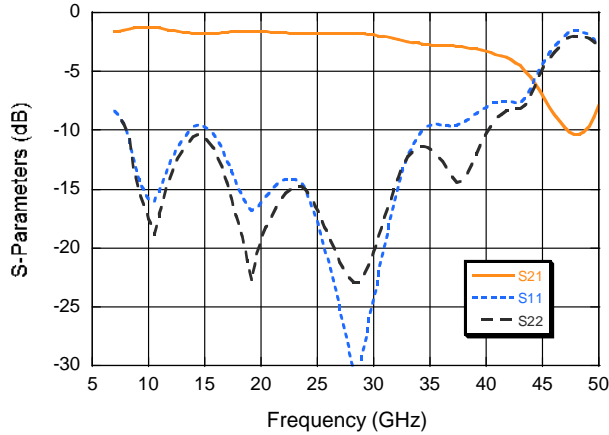

VC1 = -0.6, VC2 = -2

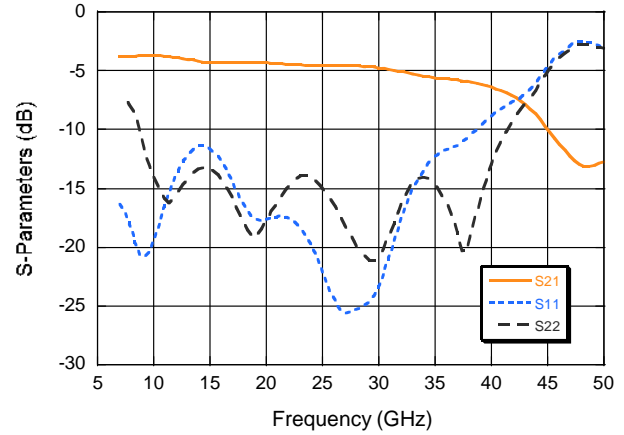

VC1 = -0.4, VC2 = -2

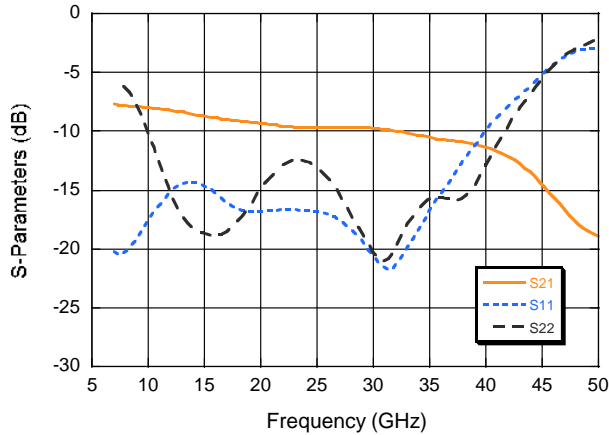

VC1 = -0.1, VC2 = -2

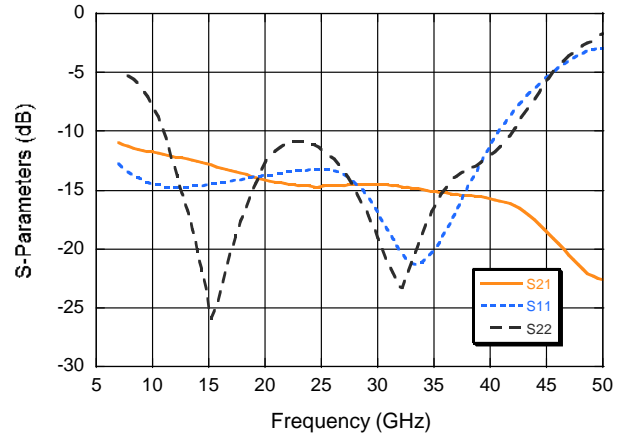

VC1 = 0, VC2 = -0.6

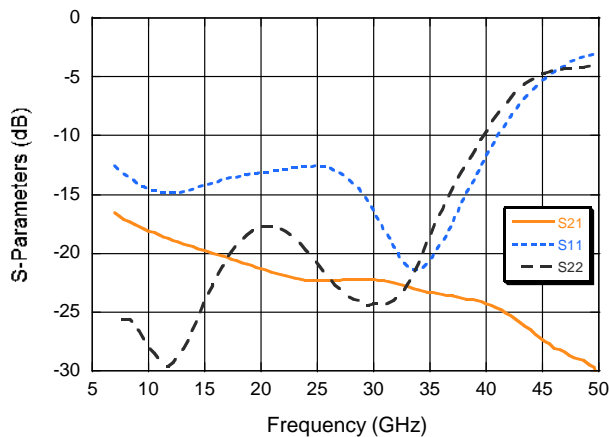

Voltage Variable Attenuator 5 - 45 GHz

Rev. V1

Typical Performance Curves: Gain

Gain vs. Pin (VC1 = -2, VC2 = -2) @ 15 GHz

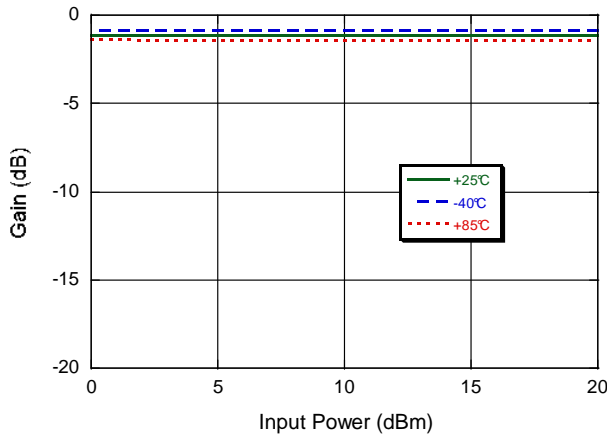

Gain vs. Pin (VC1 = -2, VC2 = -2)

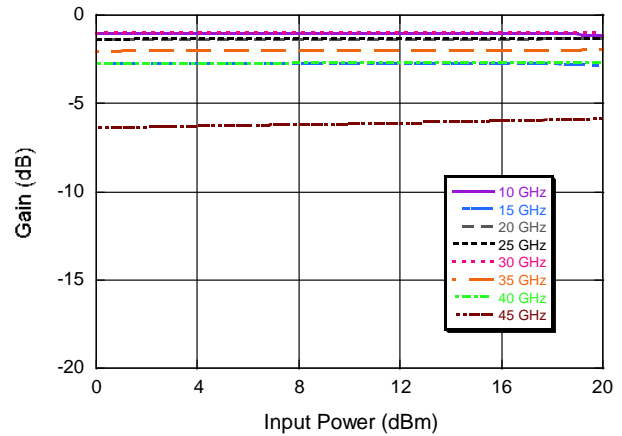

Gain vs. Pin (VC1 = -0.4, VC2 = -2) @ 15 GHz

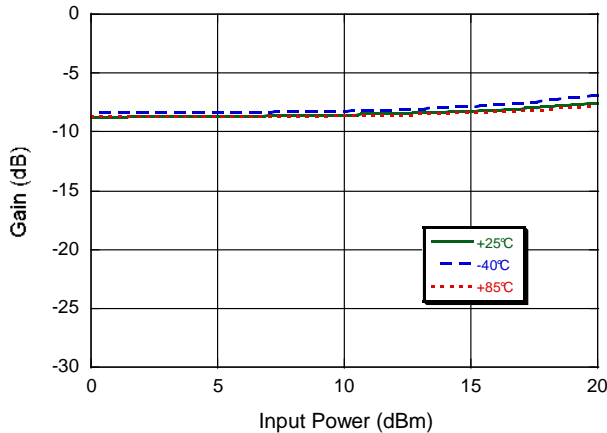

Gain vs. Pin (VC1 = -0.4, VC2 = -2)

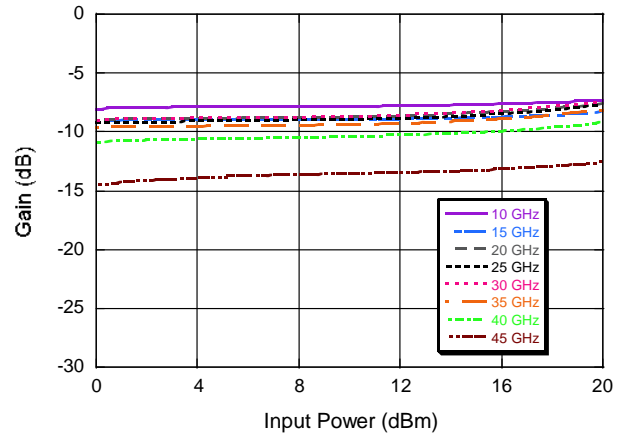

Gain vs. Pin (VC1 = 0, VC2 = -0.6) @ 15 GHz

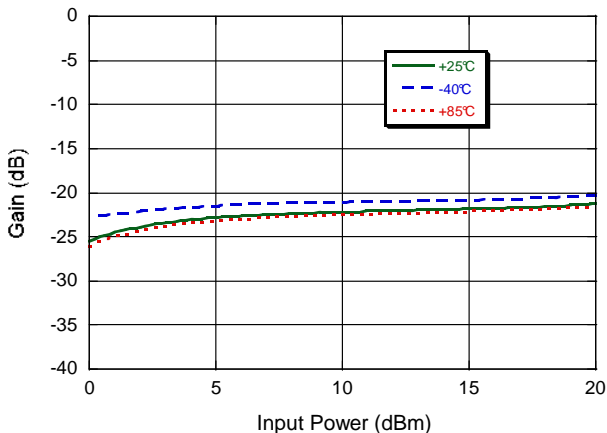

Gain vs. Pin (VC1 = 0, VC2 = -0.6)

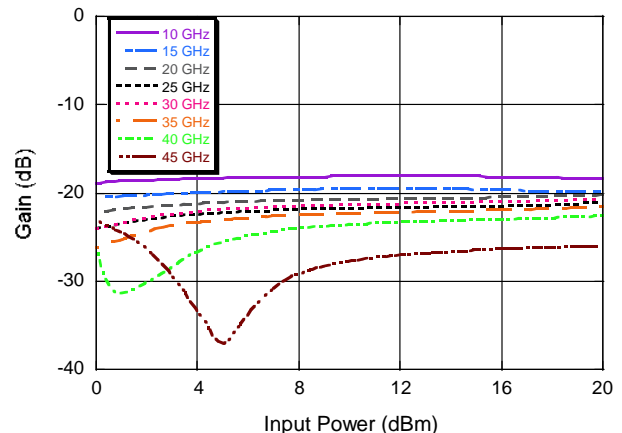

ADVANCED: Data Sheets contain information regarding a product M/A-COM Technology Solutions is considering for development. Performance is based on target specifications, simulated results, and/or prototype measurements. Commitment to develop is not guaranteed.

PRELIMINARY: Data Sheets contain information regarding a product M/A-COM Technology Solutions has under development. Performance is based on engineering tests. Specifications are typical. Mechanical outline has been fixed. Engineering samples and/or test data may be available. Commitment to produce in volume is not guaranteed.

• **North America** Tel: 800.366.2266 • **Europe** Tel: +353.21.244.6400
 • **India** Tel: +91.80.43537383 • **China** Tel: +86.21.2407.1588

Visit www.macomtech.com for additional data sheets and product information.

M/A-COM Technology Solutions Inc. and its affiliates reserve the right to make changes to the product(s) or information contained herein without notice.

Typical Performance Curves: Input IP3

Input IP3 (VC1 = -2, VC2 = -2)

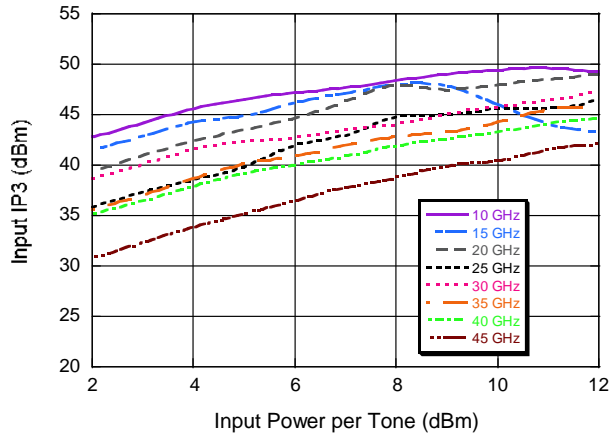

Input IP3 (Pin per tone = 10 dBm)

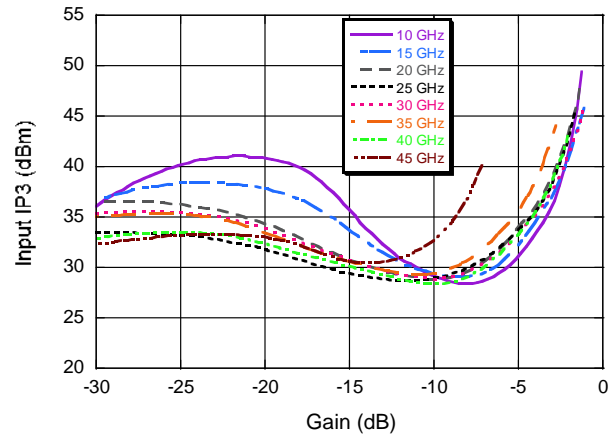

Input IP3 (VC1 = -0.4, VC2 = -2)

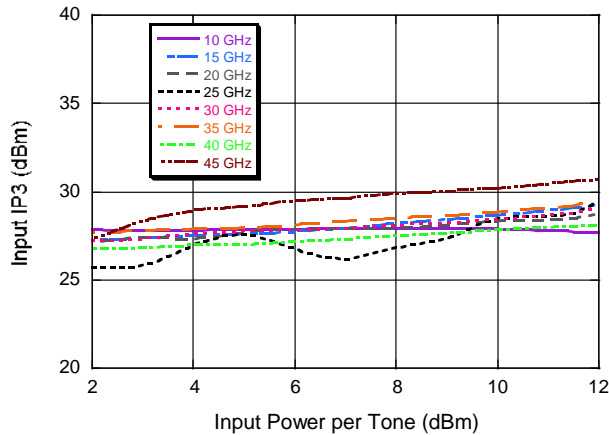

Handling Procedures

The following precautions should be observed to avoid damage:

Static Sensitivity

Gallium Arsenide Integrated Circuits are sensitive to electrostatic discharge (ESD) and can be damaged by static electricity. Proper ESD control techniques should be used when handling these class 1C (HBM) devices.

Lead-Free 3 mm 16-Lead PQFN†

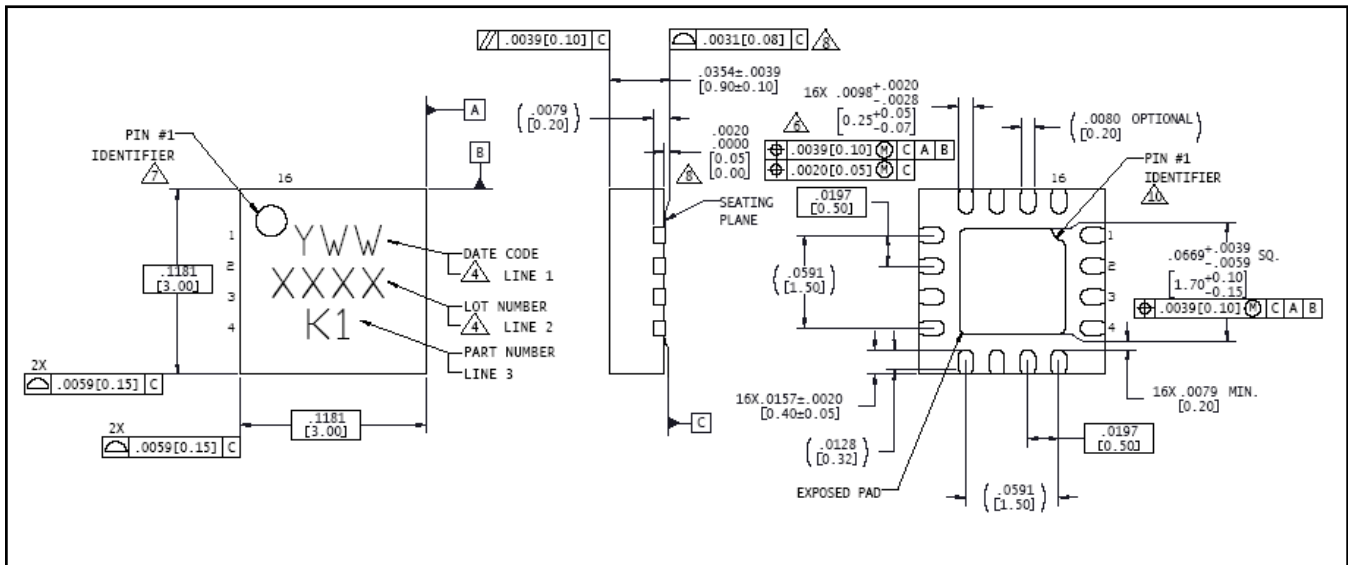

† Reference Application Note M538 for lead-free solder reflow recommendations.
Meets JEDEC moisture sensitivity level 1 requirements.
Plating is NiPdAuAg.