

FD25 / FD25C / FD25E / SFD25

Frequency Doubler

Rev. V4

Features

- Input 5 to 2400 MHz
- Output 10 to 4800 MHz
- Input Drive level +10 dBm (nominal)
- Hermetically-Sealed Package

Description

The FD25 is a passive bridge diode frequency doubler, designed for use in military, commercial and test equipment applications. The design utilizes Schottky bridge quad diodes and broadband soft dielectric and/or ferrite baluns to attain excellent performance. The use of high temperature solder assembly processes used internally makes it ideal for use in manual and semi-automated assembly. Environmental screening available to MIL-STD-883, MIL-STD-202, or MIL-DTL-28837, consult factory.

Ordering Information

Part Number	Package
FD25	TO-8
FD25C	SMA Connectorized
FD25E	Flatpack
SFD25	Surface Mount

Product Image

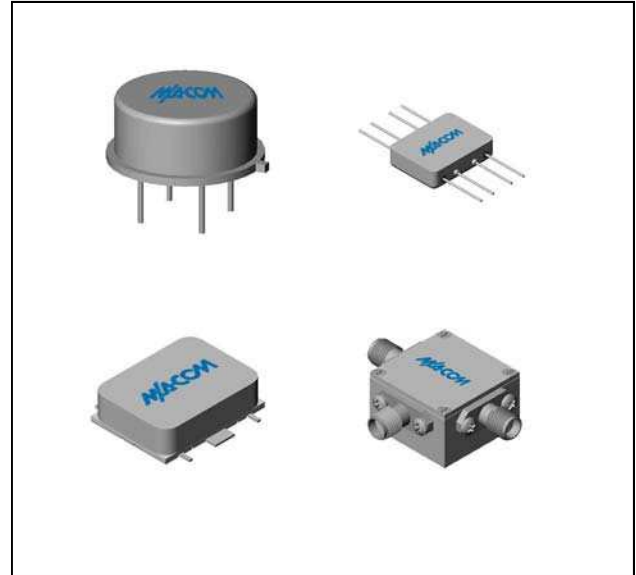

Electrical Specifications: $Z_0 = 50\Omega$ $P_{in} = +10$ dBm

Parameter	Test Conditions	Units	Typical	Guaranteed	
				+25°C	-54° to +85°C*
SSB Conversion Loss (max)	$f_{in} = 5$ to 30 MHz $f_{in} = 30$ to 2400 MHz	dB	12.0 11.5	13.0 13.0	15.0 13.5
Fundamental Suppression (min)	$f_{in} = 5$ to 1000 MHz $f_{in} = 1000$ to 2000 MHz $f_{in} = 2000$ to 2400 MHz	dBc	35 25 20	25 20 16	23 18 14
Third Harmonic Suppression	$f_{in} = 5$ to 500 MHz $f_{in} = 500$ to 1000 MHz $f_{in} = 1000$ to 2400 MHz	dBc	50 40 35	40 30 25	38 28 23
Input VSWR	$f_{in} = 5$ to 2400 MHz		1.5:1		

* The FD25C specification limits apply at 0°C to +50°C.

Typical Performance Curves

Conversion Loss vs. Frequency

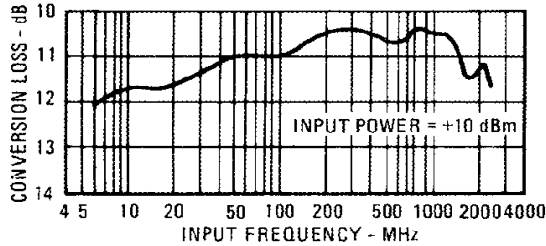

Conversion Loss vs. Input Power

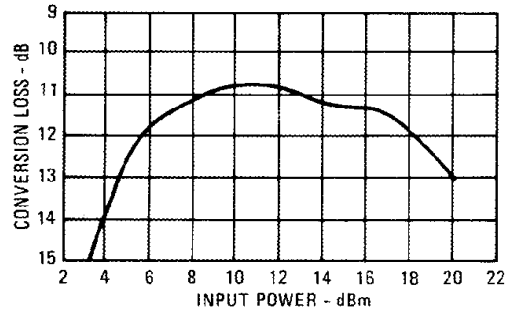

Input VSWR vs. Input Power

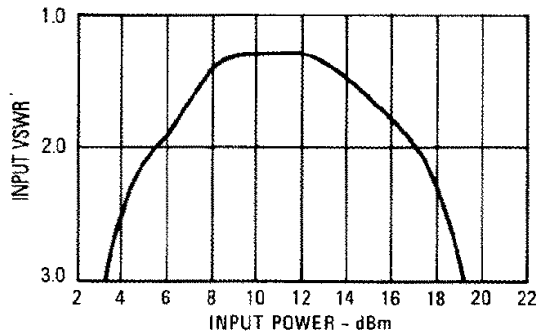

Input VSWR vs. Input Frequency

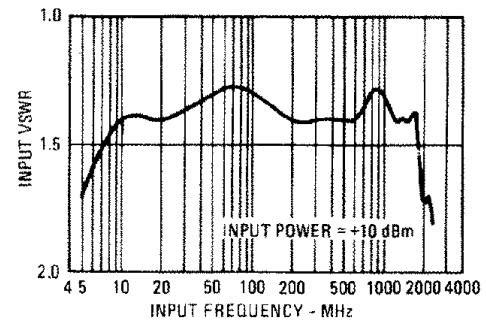

Suppression vs. Input Frequency

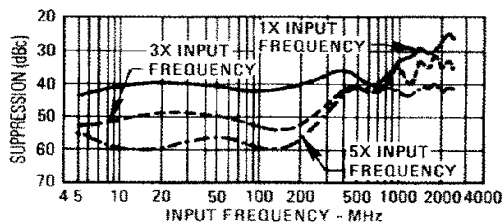

FD25 / FD25C / FD25E / SFD25



Frequency Doubler

Rev. V4

Absolute Maximum Ratings

Parameter	Absolute Maximum
Operating Temperature	-54°C to +100°C
Storage Temperature	-65°C to +100°C
Peak Input Power	+23 dBm max @ +25°C +20 dBm max @ +100°C
Peak Input Current	50 mA DC

Outline Drawing: TO-8 *

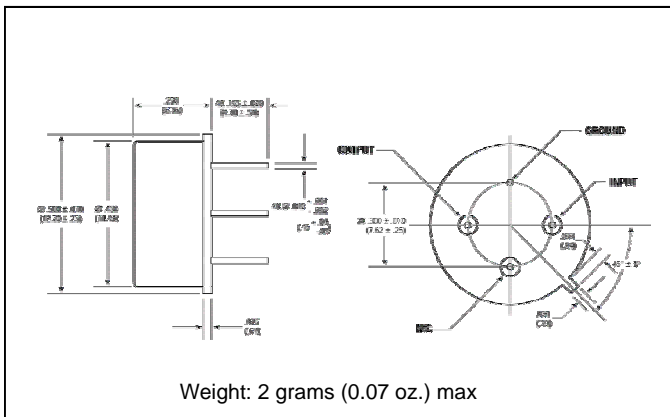

Outline Drawing: Flatpack *

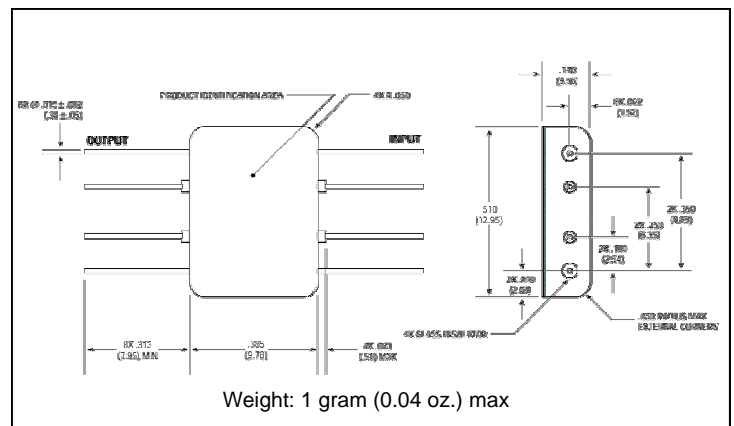

Outline Drawing: SMA Connectorized *

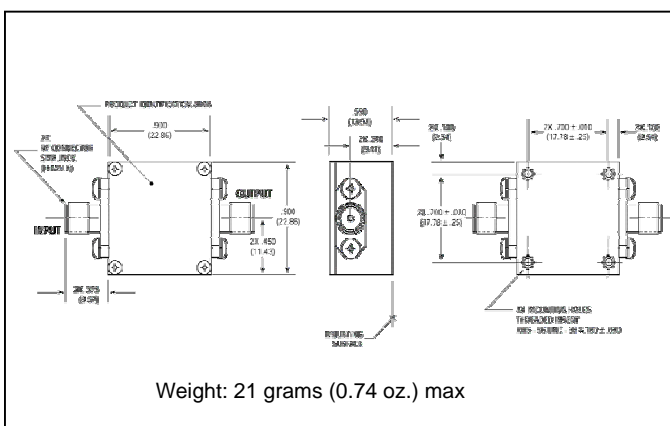

Outline Drawing: Surface Mount *

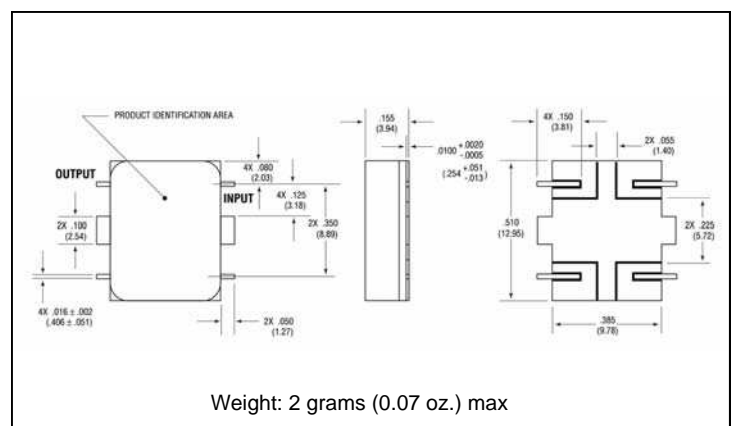

* Dimensions are inches (millimeters) ± 0.015 (0.38) unless otherwise specified.