

GaAs Pseudomorphic HEMT Transistor

Features

- ✕ Low Noise Figure 1 dB @ 12 GHz
- ✕ High Gain: 10 dB at 12 GHz
- ✕ P1dB Power: 20 dBm
- ✕ Wafer Qualification Procedure
- ✕ Customer Wafer Selection Available

General Description

Mimix CF003-03 GaAs-based transistor is a 600 um gate width, sub-half-micron gate length GaAs device with Silicon Nitride passivation. The CF003-03 provides low noise figure and wide dynamic range up to 26 GHz. It is suitable for narrow and wide band amplifiers. Superior gain makes this model useful for high gain feedback amplifiers. Its rugged construction allows it to withstand the same input power as conventional MESFET. The CF003-03 is available in chip form and is suitable for airborne, shipboard and ground-based equipment. The devices are 100% DC tested and every wafer is qualified based on sample RF and reliability testing. Screening includes MIL-STD-750 Class B, Class S and commercial screening. These devices are also available in packaged form. Please consult the CFB0303-B, CFA0303-A datasheets or contact the factory for further information.

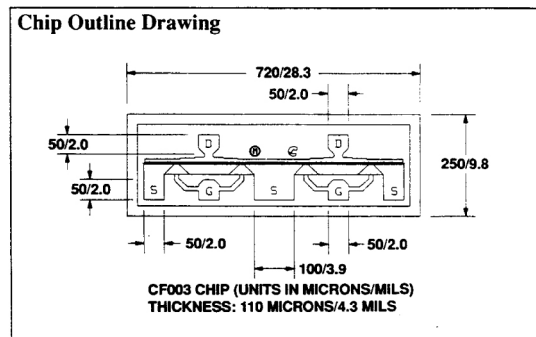

Absolute Maximum Ratings

Parameter	Symbol	Ratings
Drain-Source Voltage	V_{DS}	8V
Gate-Source Voltage	V_{GS}	-5V
Drain Current	I_{DS}	I_{DSS}
Continuous Dissipation	P_T	1600 mW
Channel Temperature	T_{CH}	175°C
Storage Temperature	T_{STG}	-65°C to +175°C

Specifications ($T_A = 25^\circ\text{C}$)				CF003-03		
Active Layer				Pseudomorphic HEMT		
Symbol	Parameters and Conditions	Frequency (GHz)	Units	Min	Typ	Max
NF_{opt}	Optimum Noise Figure $V_{DS} = 3.0\text{ V}, I_{DS} = 30\text{ mA}$	12.0	dB		1.0	1.4
G_a	Gain at NF_{opt} $V_{DS} = 3.0\text{ V}, I_{DS} = 30\text{ mA}$	12.0	dB	9.0	10.0	
$ S_{21} ^2$	50 Ohm Insertion Gain $V_{DS} = 6.0\text{ V}, I_{DS} = 80\text{ mA}$	2.0	dB		18.0	
		10.0	dB		9.0	
		18.0	dB		5.0	
P_{1dB}	Power Output @ 1 dB GC $V_{DS} = 6.0\text{ V}, I_{DS} = 80\text{ mA}$	12.0	dBm		20.0	
g_m	Transconductance $V_{DS} = 3.0\text{ V}, V_{GS} = 0\text{ V}$		mS		180	
I_{DSS}	Drain Current $V_{DS} = 3.0\text{ V}, V_{GS} = 0\text{ V}$		mA	120	180	240
V_p	Pinchoff Voltage $V_{DS} = 3.0\text{ V}, I_{DS} = 1\text{ mA}$		Volts	-0.7	-1.3	-2.5
BV_{GD}	Breakdown Voltage, Gate-Drain $I_{GD} = 100\text{ }\mu\text{A}$		Volts	-5.5	-8.0	
R_{th}	Thermal Resistance		°C/W		80	

GaAs Pseudomorphic HEMT Transistor

CF003-03

Typical Noise Parameters - CF003-03 $V_{DS} = 3.0V, I_{DS} = 30mA$

Frequency (GHz)	NF opt (dB)	Ga (dB)	Gamma opt (Mag)	(Ang)	Rn/50
2.0	0.38	18.8	0.84	14	0.29
4.0	0.50	15.8	0.70	37	0.19
6.0	0.62	13.6	0.59	61	0.16
8.0	0.74	12.1	0.52	88	0.13
10.0	0.86	11.1	0.48	114	0.09
12.0	0.98	10.4	0.47	141	0.06
14.0	1.10	9.9	0.48	166	0.04
16.0	1.22	9.3	0.49	-171	0.04
18.0	1.34	8.6	0.51	-151	0.07
20.0	1.46	7.4	0.53	-135	0.14

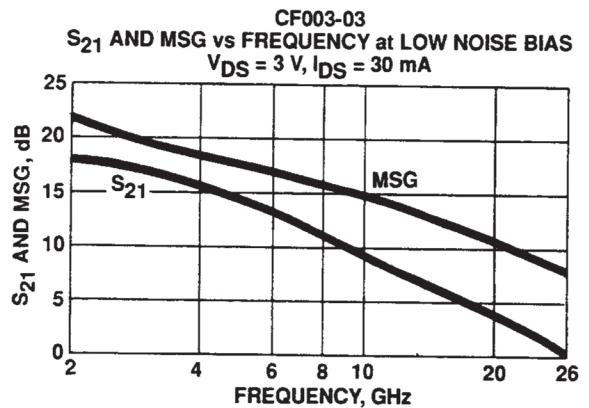
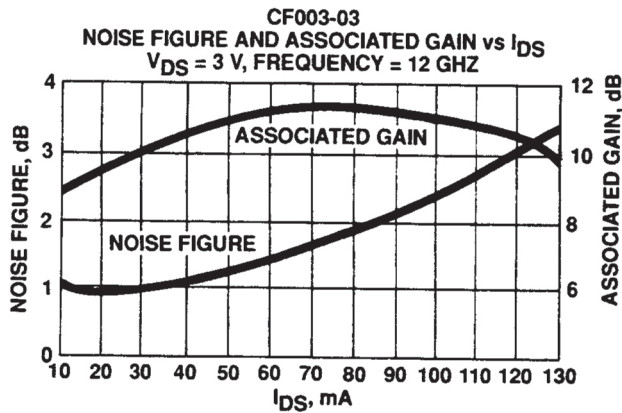
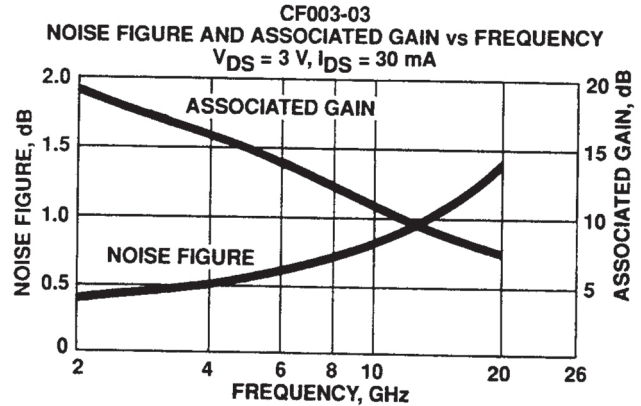

CF003-03
 S_{11} AND S_{22} vs FREQUENCY at LOW NOISE BIAS
 $V_{DS} = 3V, I_{DS} = 30mA$

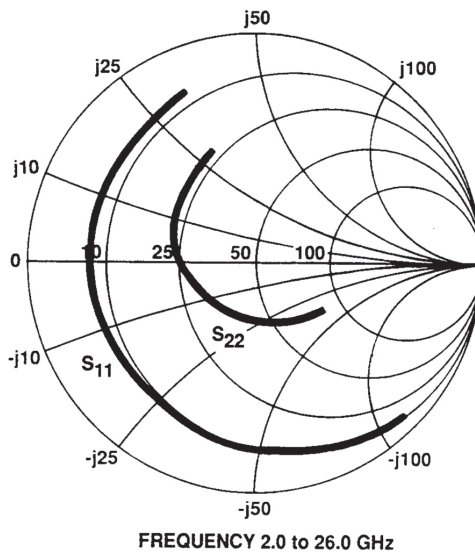

GaAs Pseudomorphic HEMT Transistor

July 2008 - Rev 19-Jul-08

CF003-03

CF003-03

CF003-03 at Low Noise Bias

$V_{DS} = 3\text{ V}$, $I_{DS} = 30\text{ mA}$

Frequency (GHz)	S_{11}		S_{21}			S_{12}			S_{22}		K	MSG (dB)
	(Mag)	(Ang)	(dB)	(Mag)	(Ang)	(dB)	(Mag)	(Ang)	(Mag)	(Ang)		
2.0	0.92	-58	18.0	7.93	139	-25.7	0.05	60	0.32	-48	0.21	21.9
4.0	0.81	-103	15.5	5.95	109	-22.2	0.08	40	0.24	-94	0.40	18.8
6.0	0.75	-127	13.2	4.55	91	-21.0	0.09	31	0.20	-118	0.56	17.1
8.0	0.73	-151	11.0	3.54	74	-20.7	0.09	24	0.23	-147	0.70	15.8
10.0	0.71	-169	9.0	2.80	61	-21.0	0.09	19	0.27	-159	0.91	15.0
12.0	0.73	180	7.5	2.38	49	-20.5	0.10	16	0.30	-169	0.93	14.0
14.0	0.73	168	6.4	2.08	38	-20.2	0.10	11	0.33	-177	1.01	13.3
16.0	0.73	154	5.5	1.89	26	-19.5	0.11	7	0.33	174	1.04	12.5
18.0	0.74	141	4.8	1.74	12	-18.9	0.11	1	0.33	150	1.06	11.8
20.0	0.76	132	3.7	1.53	-2	-18.2	0.12	-3	0.40	126	1.07	10.9
22.0	0.82	124	2.4	1.32	-13	-17.7	0.13	-9	0.50	114	0.87	10.1
24.0	0.79	118	0.7	1.08	-20	-17.1	0.14	-9	0.51	114	1.05	8.9
26.0	0.84	120	-0.2	0.98	-24	-16.7	0.15	-11	0.53	114	0.84	8.2

Device Model

Parameters	CF003-01	CF003-03	Units
	$V_{DS} = 6\text{ V}$, $I_{DS} = 80\text{ mA}$	$V_{DS} = 3\text{ V}$, $I_{DS} = 30\text{ mA}$	
L_g	0.21	0.20	nH
R_g	0.50	0.50	Ω
C_{gs}	0.71	0.55	pF
R_i	1.4	1.4	Ω
C_{gd}	0.053	0.068	pF
G_m	134	158	mS
τ	2.8	2.3	ps
C_{ds}	0.16	0.15	pF
R_{ds}	87	92	Ω
R_d	0.67	0.67	Ω
L_d	0.21	0.22	nH
R_s	0.53	0.80	Ω
L_s	0.4	0.05	nH

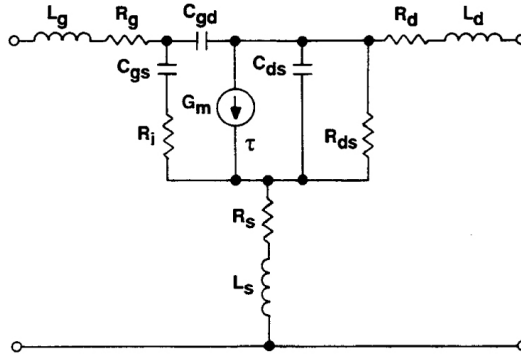

Wafer Qualification Procedure

100% DC Test 100% Visual Insp.	
Sample Chip Performance Test	NF, Power, S-Parameters, IP3, Power Blast
Sample Circuit Performance Tests 6-18 GHz Module	NF, Power, Gain, VSWR
Reliability Assessment	Power Blast & Burn-in
80% of tested samples must meet specifications for wafer acceptance.	

GaAs Pseudomorphic HEMT Transistor

Handling and Assembly Information

CAUTION! - Mimix Broadband MMIC Products contain gallium arsenide (GaAs) which can be hazardous to the human body and the environment. For safety, observe the following procedures:

- *Do not ingest.*
- *Do not alter the form of this product into a gas, powder, or liquid through burning, crushing, or chemical processing as these by-products are dangerous to the human body if inhaled, ingested, or swallowed.*
- *Observe government laws and company regulations when discarding this product. This product must be discarded in accordance with methods specified by applicable hazardous waste procedures.*

Life Support Policy - Mimix Broadband's products are not authorized for use as critical components in life support devices or systems without the express written approval of the President and General Counsel of Mimix Broadband. As used herein: (1) Life support devices or systems are devices or systems which, (a) are intended for surgical implant into the body, or (b) support or sustain life, and whose failure to perform when properly used in accordance with instructions for use provided in the labeling, can be reasonably expected to result in a significant injury to the user. (2) A critical component is any component of a life support device or system whose failure to perform can be reasonably expected to cause the failure of the life support device or system, or to affect its safety or effectiveness.

ESD - Gallium Arsenide (GaAs) devices are susceptible to electrostatic and mechanical damage. Die are supplied in antistatic containers, which should be opened in cleanroom conditions at an appropriately grounded antistatic workstation. Devices need careful handling using correctly designed collets, vacuum pickups or, with care, sharp tweezers.

Die Attach: Conductive epoxy or preform die attach is recommended. For preform die attach: Preform: AuSn (80% Au, 20% Sn); Stage Temperature: 290 °C, +/-5 °C; Handling Tool: Tweezers; Time: 1 min or less.

Wire Bonding: Wire Size: 0.7 to 1.0 mil in diameter (pre-stressed); Thermocompression bonding is preferred over thermosonic bonding. For thermocompression bonding: Stage Temperature: 250 °C ; Bond Tip Temperature: 150 °C; Bonding Tip Pressure: 18 to 40 gms depending on size of wire.

RoHS Compliant Parts - All Mimix products are RoHS compliant unless otherwise specified.

Ordering Information

Part Number for Ordering

CF003-03-000X

Description

Where "X" is RoHS compliant die packed in "V" - vacuum release gel packs or "W" - waffle trays



Proper ESD procedures should be followed when handling this device.