

Thin Film Limiter Module 5 to 3000 MHz

Rev. V2

Features

- VOLTAGE VARIABLE LIMITING LEVEL: -10 TO 0 dBm
- LOW INSERTION LOSS AT LOW INPUT LEVELS: < 2.0 dB (TYP.)
- GOOD SUPPRESSION OF EVEN ORDER HARMONICS DUE TO BALANCED CIRCUIT DESIGN
- EXCELLENT PHASE RESPONSE 0.3 DEGREE / dB TO 160 MHz (TYP.)

Description

The L1 signal limiter is a discrete hybrid design, which uses thin film manufacturing processes for accurate performance and high reliability. This design uses Schottky bridge quad and anti-parallel diodes, which provide consistent limiting levels over a broadband frequency range. Both TO-8 and SMTO-8 packages are hermetically sealed, and MIL-STD-883 environmental screening is available.

Ordering Information

Part Number	Package
L1	TO-8
SML1	Surface Mount
CL1 **	SMA Connectorized

** The connectorized version is not RoHs compliant.

Product Image

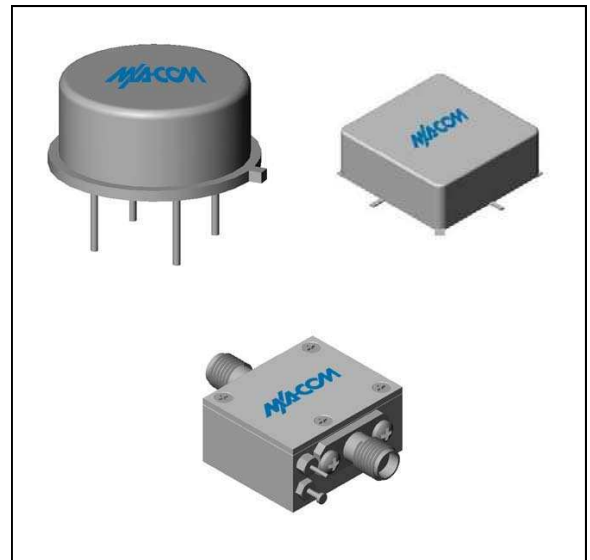

Electrical Specifications: $Z_0 = 50\Omega$, $V_{CC} = +15 V_{DC}$

Parameter	Units	Typical	Guaranteed	
		25°C	0° to 50°C	-54° to +85°C*
Frequency	MHz	5-3200	5-3000	5-3000
Insertion Loss @ $P_{IN} \leq -20$ dBm (max.)	5-1000 MHz	2.0	3.0	3.5
	1000-3000 MHz	3.0	4.5	4.5
Input VSWR (max.) $P_{IN} \leq -10$ dBm, $+10 \leq \text{Bias} \leq +20 V_{dc}$		1.7:1	1.9:1	2.1:1
Output VSWR (max.) $P_{IN} \leq -10$ dBm, $+10 \leq \text{Bias} \leq +20 V_{dc}$	5-1000 MHz	1.7:1	2.0:1	2.2:1
	1000-3000 MHz	2.0:1	2.3:1	2.5:1
Output Limiting Level @ $P_{IN} = +20$ dBm (max.)	5-2000 MHz	2.5	4.0	4.5
	2000-3000 MHz	6.5	7.0	7.0
Bias Current (max.)	@ 15 Vdc	7.0	9.0	10.0
	@ 20 Vdc	10.0		

* Over temperature performance limits for part number CL1, guaranteed from 0°C to +50°C only.

Absolute Maximum Ratings

Parameter	Absolute Maximum
Storage Temperature	-62°C to +125°C
Case Temperature	+125°C
DC Voltage	+25 V
Continuous Input Power	+20 dBm
Short Term Input power (1 minute max.)	400 mW
Peak Power (3 μ sec max.)	1 W
"S" Series Burn-In Temperature (case)	+125°C

Limiting and Insertion Loss Characteristics at +25°C

Bias Voltage	Output Level at Limiting Threshold (1 dB comp.)		
	50 MHz	Typical 500 MHz	1000 MHz
+20 Volts	-0.8 dBm	-1.0 dBm	-1.0 dBm
+15 Volts	-2.0 dBm	-2.0 dBm	-2.2 dBm
+10 Volts	-4.5 dBm	-5.0 dBm	-5.5 dBm
+5 Volts	-11.5 dBm	-11.8 dBm	-12.0 dBm

1

ADVANCED: Data Sheets contain information regarding a product M/A-COM Technology Solutions is considering for development. Performance is based on target specifications, simulated results, and/or prototype measurements. Commitment to develop is not guaranteed.

PRELIMINARY: Data Sheets contain information regarding a product M/A-COM Technology Solutions has under development. Performance is based on engineering tests. Specifications are typical. Mechanical outline has been fixed. Engineering samples and/or test data may be available. Commitment to produce in volume is not guaranteed.

• **North America** Tel: 800.366.2266 • **Europe** Tel: +353.21.244.6400
 • **India** Tel: +91.80.4155721 • **China** Tel: +86.21.2407.1588
 Visit www.macomtech.com for additional data sheets and product information.

M/A-COM Technology Solutions Inc. and its affiliates reserve the right to make changes to the product(s) or information contained herein without notice.

Typical Performance Curves at +25°C

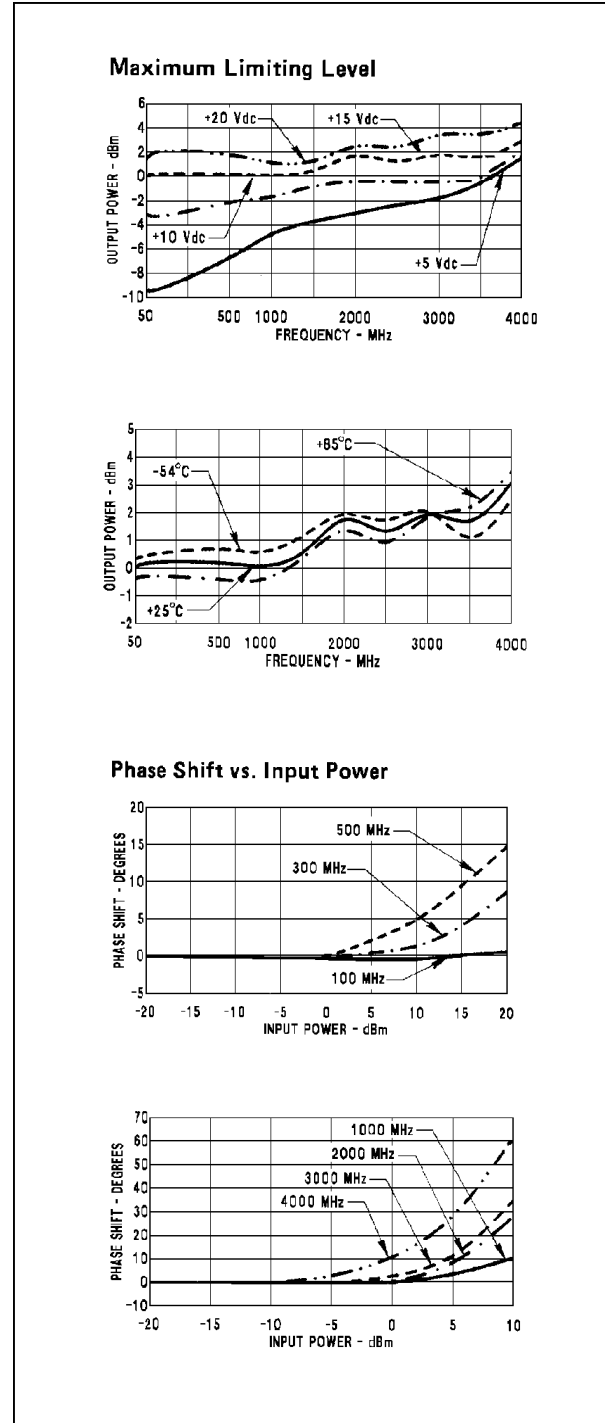
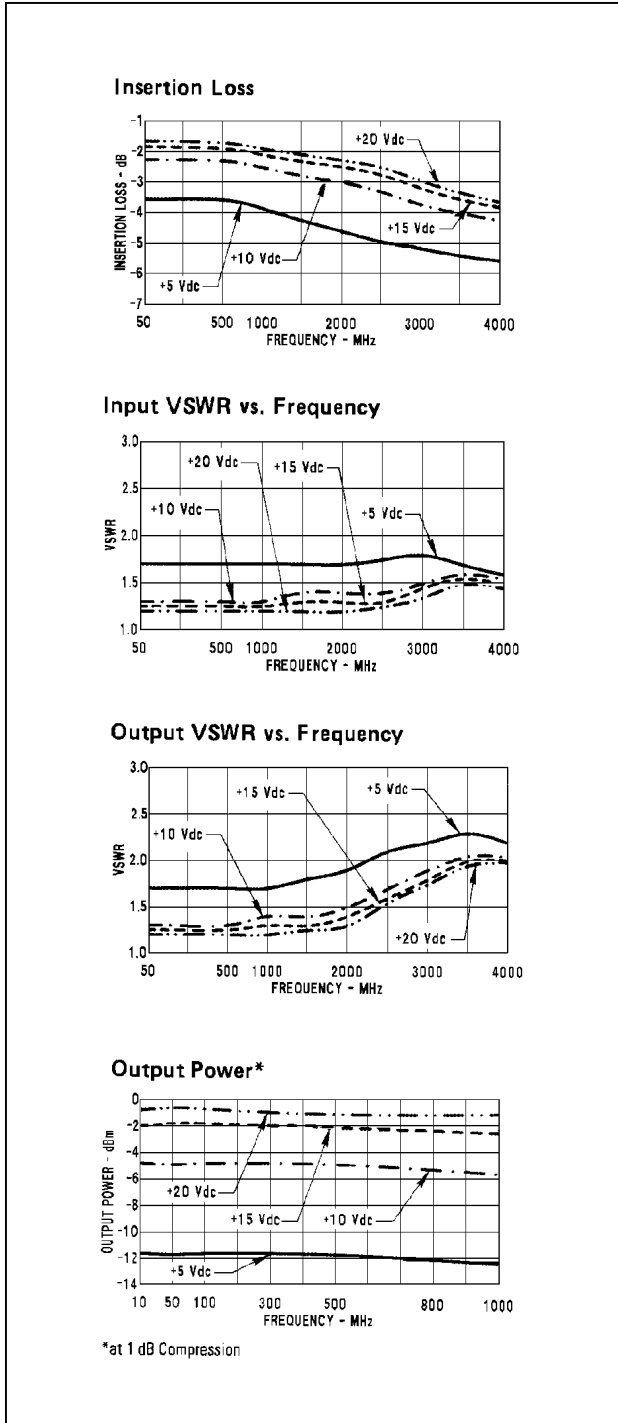

Thin Film Limiter Module 5 to 3000 MHz

Rev. V2

Typical Performance Curves at +25°C

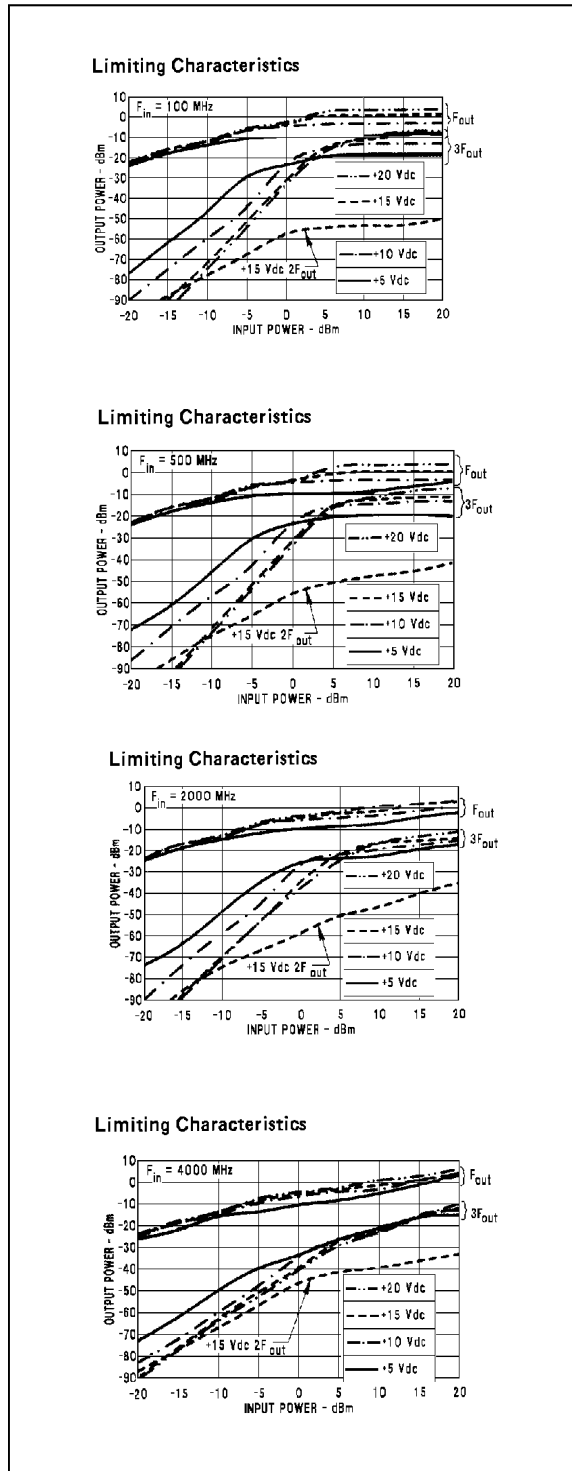

Outline Drawing: TO-8 *

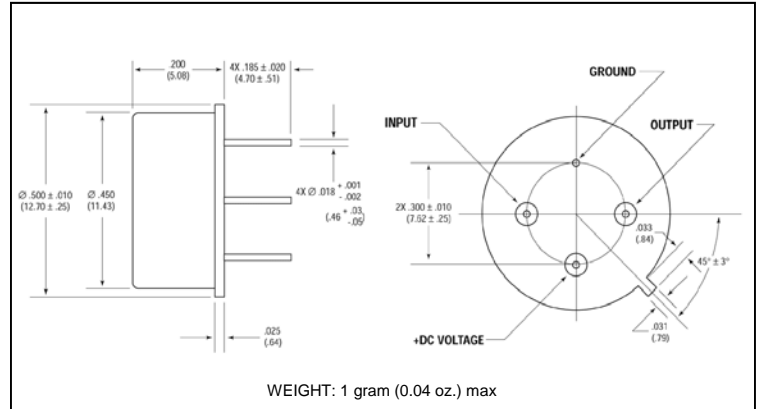

Outline Drawing: Surface Mount *

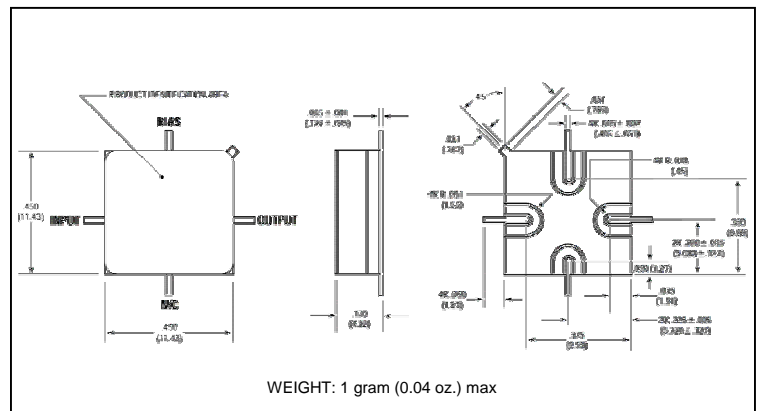

Outline Drawing: SMA Connectorized *

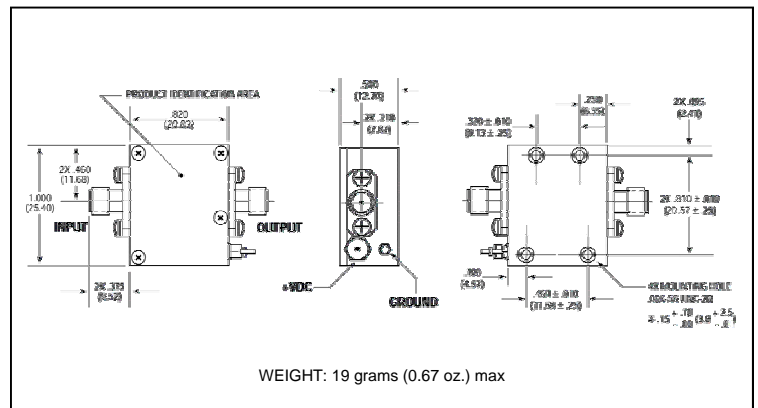

* Dimensions are inches (millimeters) ± 0.015 (0.38) unless otherwise specified.

ADVANCED: Data Sheets contain information regarding a product M/A-COM Technology Solutions is considering for development. Performance is based on target specifications, simulated results, and/or prototype measurements. Commitment to develop is not guaranteed.
PRELIMINARY: Data Sheets contain information regarding a product M/A-COM Technology Solutions has under development. Performance is based on engineering tests. Specifications are typical. Mechanical outline has been fixed. Engineering samples and/or test data may be available. Commitment to produce in volume is not guaranteed.

• **North America** Tel: 800.366.2266 • **Europe** Tel: +353.21.244.6400
 • **India** Tel: +91.80.4155721 • **China** Tel: +86.21.2407.1588
 Visit www.macomtech.com for additional data sheets and product information.

M/A-COM Technology Solutions Inc. and its affiliates reserve the right to make changes to the product(s) or information contained herein without notice.