

Features

- Low Noise Figure: 1.15 dB
- High Gain: 27 dB
- Low Power Consumption: 5V, 20 mA
- High Dynamic Range
- Lead-Free SOIC-8 Package
- 100% Matte Tin Plating over Copper
- Halogen-Free “Green” Mold Compound
- 260°C Reflow Compatible
- RoHS* Compliant Version of AM50-0002

Description

M/A-COM's MAALSS0042 is a high performance GaAs MMIC low noise amplifier in a lead-free SOIC 8-lead surface mount plastic package. The MAALSS0042 employs a monolithic 3-stage self-bias design and a simple external matching network to obtain minimum noise figure.

The MAALSS0042 is ideally suited for use where low noise figure, high gain, high dynamic range and low power consumption are required. Typical applications include receiver front ends in the Global Positioning System (GPS) market, as well as standard gain blocks, buffer amps, driver amps, and IF amps in both fixed and portable systems.

M/A-COM'S MAALSS0042 is fabricated using a mature 0.5-micron gate length GaAs process. The process features full passivation for increased performance reliability.

Ordering Information ^{1,2}

Part Number	Package
MAALSS0042	Bulk Packaging
MAALSS0042TR-3000	3000 piece reel
MAALSS0042SMB	Sample Test Board

1. Reference Application Note M513 for reel size information.
2. Die quantity varies.

Functional Diagram

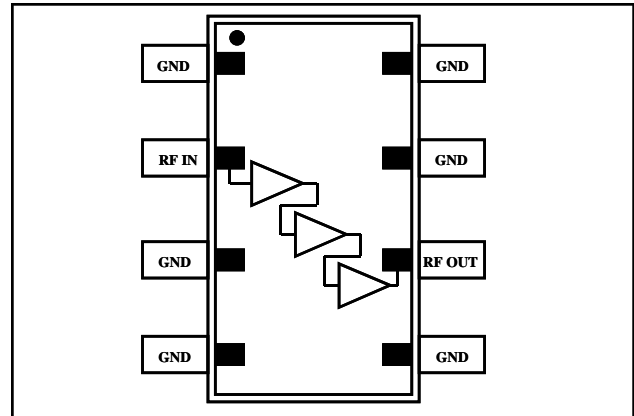

Pin Configuration ^{3,4,5}

Pin No.	Pin Name	Description
1	GND	Ground
2	RF IN	RF Input
3	GND	Ground
4	GND	Ground
5	GND	Ground
6	RF OUT	RF Output, V _{DD}
7	GND	Ground
8	GND	Ground

3. Pins 1, 3, 4, 5, 7, and 8 must be RF and DC grounded (see Recommended PCB Configuration).
4. Pin 2 is the RF input and must be connected to the simple matching network shown in the Application Schematic.
5. Pin 6 is the RF output. V_{DD} is also applied on Pin 6.

Absolute Maximum Ratings ^{6,7}

Parameter	Absolute Maximum
V _{DD}	+10 VDC
Input Power	17 dBm
Channel Temperature ⁸	+150 °C
Operating Temperature	-40 °C to +85 °C
Storage Temperature	-65 °C to +150 °C

6. Exceeding any one or combination of these limits may cause permanent damage to this device.
7. M/A-COM does not recommend sustained operation near these survivability limits.
8. Typical thermal resistance (θ_{jc}) = +165 °C/W

* Restrictions on Hazardous Substances, European Union Directive 2002/95/EC.

ADVANCED: Data Sheets contain information regarding a product M/A-COM Technology Solutions is considering for development. Performance is based on target specifications, simulated results, and/or prototype measurements. Commitment to develop is not guaranteed.

PRELIMINARY: Data Sheets contain information regarding a product M/A-COM Technology Solutions has under development. Performance is based on engineering tests. Specifications are typical. Mechanical outline has been fixed. Engineering samples and/or test data may be available. Commitment to produce in volume is not guaranteed.

- **North America** Tel: 800.366.2266 / Fax: 978.366.2266
 - **Europe** Tel: 44.1908.574.200 / Fax: 44.1908.574.300
 - **Asia/Pacific** Tel: 81.44.844.8296 / Fax: 81.44.844.8298
- Visit www.macomtech.com for additional data sheets and product information.

M/A-COM Technology Solutions Inc. and its affiliates reserve the right to make changes to the product(s) or information contained herein without notice.

Low Noise Amplifier 1.575 GHz

Rev. V1

Electrical Specifications: $T_A = +25^\circ\text{C}$, $V_{DD} = +5\text{ V}$, $Z_0 = 50\ \Omega$

Parameter	Test Conditions	Units	Min.	Typ.	Max.
Gain	$F = 1.575\text{ GHz}$, $P_{IN} = -35\text{ dBm}$	dB	25	27	29
Noise Figure	$F = 1.575\text{ GHz}$, $P_{IN} = -35\text{ dBm}$	dB	-	1.15	1.4
Input VSWR	$F = 1.575\text{ GHz}$, $P_{IN} = -35\text{ dBm}$	Ratio	-	2.0:1	-
Output VSWR	$F = 1.575\text{ GHz}$, $P_{IN} = -35\text{ dBm}$	Ratio	-	1.5:1	-
Output P1dB	$F = 1.575\text{ GHz}$	dBm	-	1	-
Input IP_3	$F = 1.575\text{ GHz}$, $P_{IN} = -35\text{ dBm}$	dBm	-	-14	-
Reverse Isolation	$F = 1.575\text{ GHz}$, $P_{IN} = -35\text{ dBm}$	dB	-	48	-
Bias Current	—	mA	15	20	25

Recommended PCB Configuration

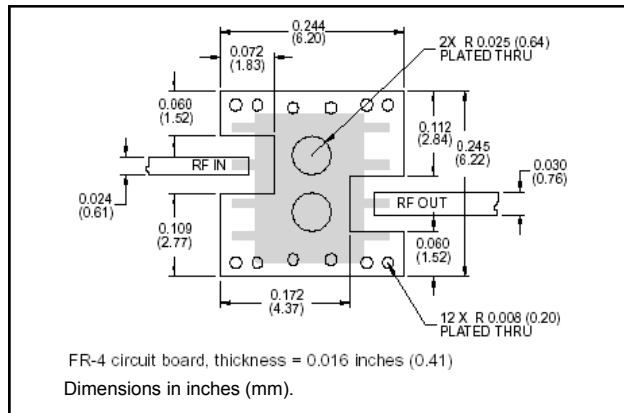

Application Schematic

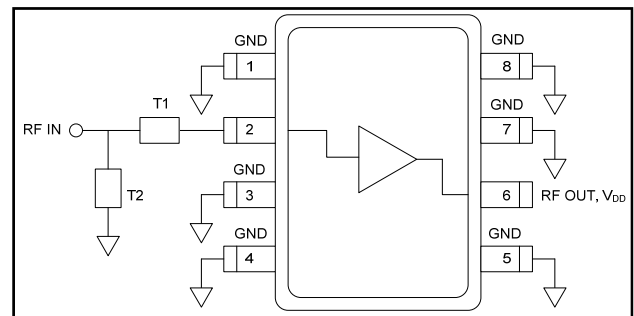

Frequency = 1.575 GHz		
	Impedance	Electrical Length
T1	57.2 Ω	36.0°
T2	82.7 Ω	16.2°

Lead-Free SOIC-8†

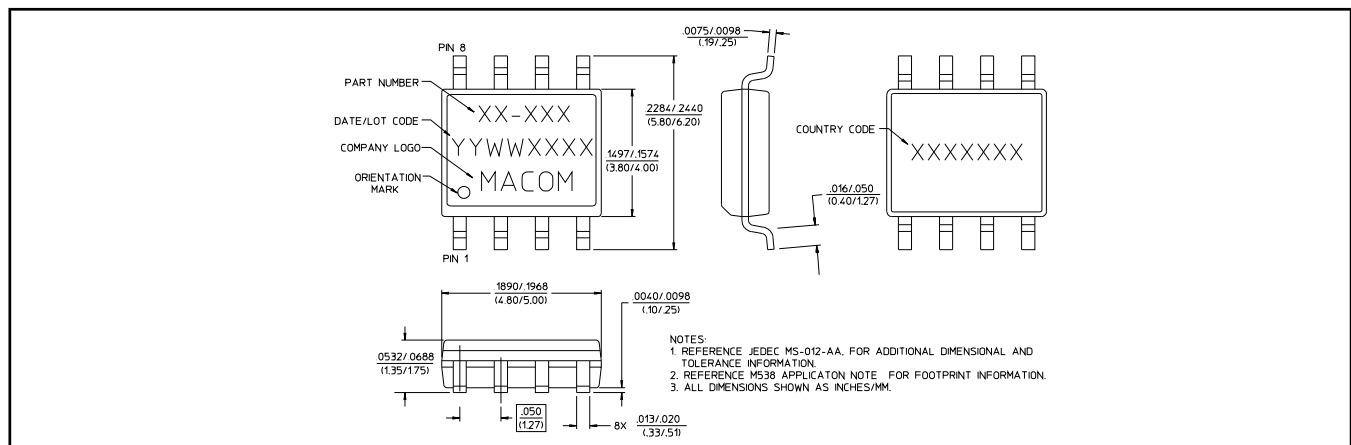

† Reference Application Note M538 for lead-free solder reflow recommendations.
Meets JEDEC moisture sensitivity level 1 requirements.

2

ADVANCED: Data Sheets contain information regarding a product M/A-COM Technology Solutions is considering for development. Performance is based on target specifications, simulated results, and/or prototype measurements. Commitment to develop is not guaranteed.
PRELIMINARY: Data Sheets contain information regarding a product M/A-COM Technology Solutions has under development. Performance is based on engineering tests. Specifications are typical. Mechanical outline has been fixed. Engineering samples and/or test data may be available. Commitment to produce in volume is not guaranteed.

- **North America** Tel: 800.366.2266 / Fax: 978.366.2266
- **Europe** Tel: 44.1908.574.200 / Fax: 44.1908.574.300
- **Asia/Pacific** Tel: 81.44.844.8296 / Fax: 81.44.844.8298

Visit www.macontech.com for additional data sheets and product information.

M/A-COM Technology Solutions Inc. and its affiliates reserve the right to make changes to the product(s) or information contained herein without notice.

Typical Performance

Gain, $T_A = +25^\circ\text{C}$

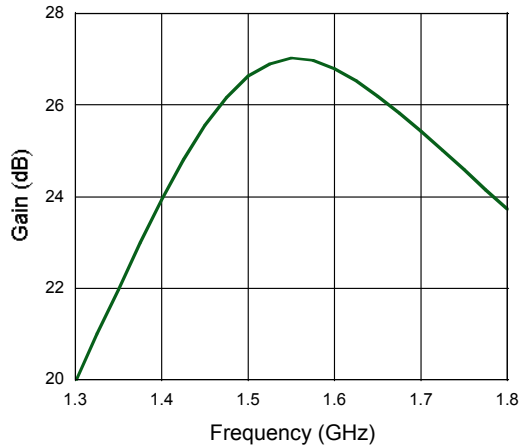

Gain over Temperature

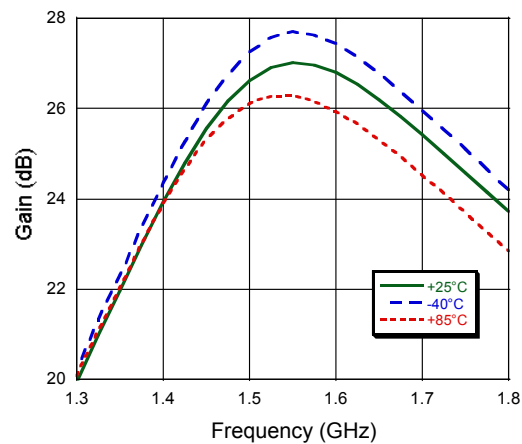

Noise Figure, $T_A = +25^\circ\text{C}$

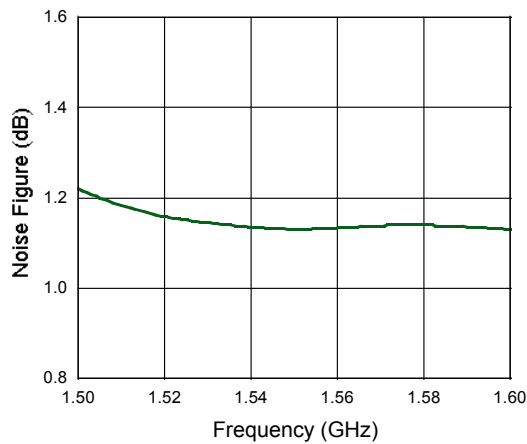

Noise Figure over Temperature

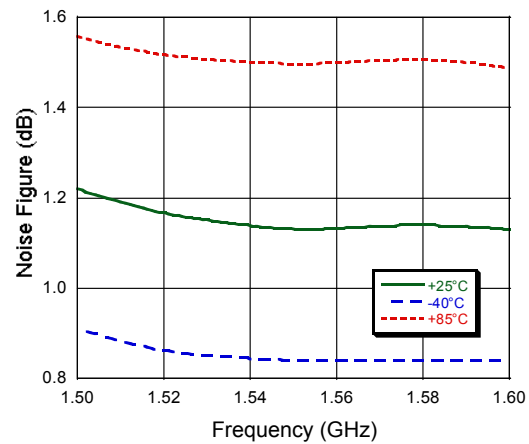

Input IP_3 , $T_A = +25^\circ\text{C}$

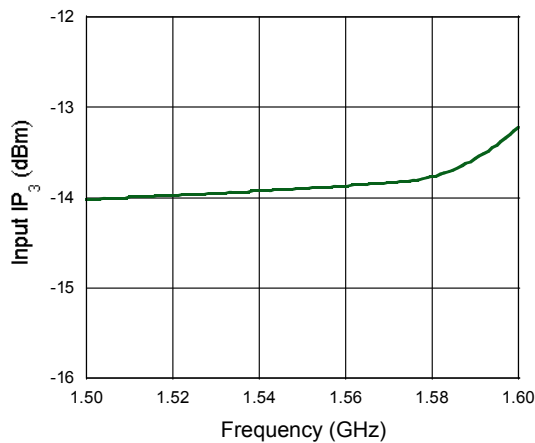

VSWR, $T_A = +25^\circ\text{C}$

