

## Features

- Gain: 22 dB
- P1dB: 27 dBm
- High Linearity, OIP3: 38 dBm
- Integrated Power Detector
- Lead-Free 7 mm Laminate Package
- RoHS\* Compliant and 260°C Reflow Compatible

## Description

The MAAP-010512 is a 4-stage, high linearity 1W power amplifier in a 7x7 mm laminate package, allowing easy assembly. This PA product is fully matched to 50 ohms on both the input and output. It is designed for use as a power amplifier stage in transmit chains and is ideally suited for 42 GHz band point-to-point radios.

Each device is 100% RF tested to ensure performance compliance. The part is fabricated using an efficient pHEMT process.

## Functional Schematic

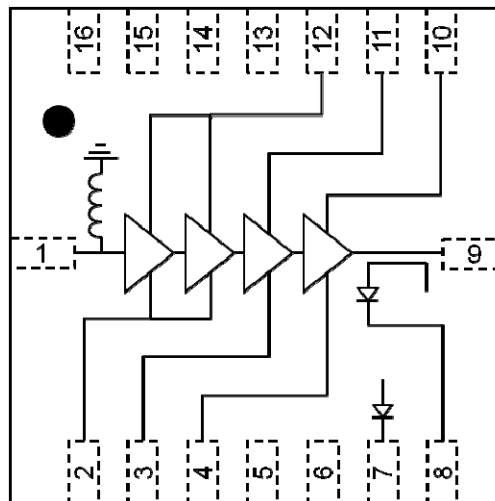

## Pin Configuration <sup>1,2</sup>

Pin No.	Function	Pin No.	Function
1	RF <sub>IN</sub>	9	RF <sub>OUT</sub>
2	V <sub>G1</sub>	10	V <sub>D3</sub>
3	V <sub>G2</sub>	11	V <sub>D2</sub>
4	V <sub>G3</sub>	12	V <sub>D1</sub>
5	No Connection	13	No Connection
6	No Connection	14	No Connection
7	V <sub>REFERENCE</sub>	15	No Connection
8	V <sub>DETECTOR</sub>	16	No Connection
		Paddle	Ground

1. M/A-COM Technology Solutions recommends connecting unused package pins to ground.
2. The exposed pad centered on the package bottom must be connected to RF and DC ground.

## Ordering Information

Part Number	Package
MAAP-010512-000000	Bulk quantity
MAAP-010512-TR0500	500 Piece Reel
MAAP-010512-001SMB	Sample Evaluation board

\* Restrictions on Hazardous Substances, European Union Directive 2002/95/EC.

## Electrical Specifications:

**Freq: 40.5 - 43.5 GHz, VD = 4 V, ID1 = 217 mA, ID2 = 300 mA, ID3 = 600 mA, T<sub>A</sub> = 25°C**

Parameter	Units	Min.	Typ.	Max.
Small Signal Gain	dB	18.0	22.0	27.0
Gain Flatness cross Band	dB	-	+/-1.0	-
Input Return Loss	dB	-	15	-
Output Return Loss	dB	-	12	-
Reverse Isolation	dB	-	50	-
Output P1dB	dBm	-	27.0	-
Output IP3	dBm	32.5	38.0	-
Saturated Output Power	dBm	25.0	29.0	-
Output IMD3 with Pout (scl) = 14 dBm	dBc	37.0	48.0	-
Supply Current <sup>3</sup>	mA	-	1117	1300

3. Adjust Vgs between -1.0 V and -0.1 V to achieve specified supply current. Typical current 1117 mA = 217 (ID1) + 300 (ID2) + 600 (ID3)

## Absolute Maximum Ratings<sup>4,5,6</sup>

Parameter	Absolute Max.
Drain Voltage	+4.3 V
Gate Bias Voltage	-1.5 V < Vg < 0 V
Input Power	15 dBm
Junction Temperature <sup>7</sup>	150°C
Operating Temperature	-40°C to +85°C
Storage Temperature	-55°C to +150°C

4. Exceeding any one or combination of these limits may cause permanent damage to this device.

5. M/A-COM Technology Solutions does not recommend sustained operation near these survivability limits.

6. Operating at nominal conditions with T<sub>J</sub> ≤ 150°C will ensure MTTF > 1 x 10<sup>6</sup> hours.

7. Junction Temperature (T<sub>J</sub>) = T<sub>C</sub> + Θ<sub>jc</sub> \* (V \* I)  
Typical thermal resistance (Θ<sub>jc</sub>) = 11.2° C/W.

a) For T<sub>C</sub> = 25°C,

T<sub>J</sub> = 75°C @ 4 V, 1117 mA

b) For T<sub>C</sub> = 85°C,

T<sub>J</sub> = 135°C @ 4 V, 1117 mA

## Handling Procedures

Please observe the following precautions to avoid damage:

## Static Sensitivity

Gallium Arsenide Integrated Circuits are sensitive to electrostatic discharge (ESD) and can be damaged by static electricity. Proper ESD control techniques should be used when handling these Human Body Model Class 1A devices.

**Amplifier, Power, 0.8 W  
40.5 - 43.5 GHz**

V2

**Typical Performance Curves:  $V_D = 4\text{ V}$ ,  $I_{D1} = 217\text{ mA}$ ,  $I_{D2} = 300\text{ mA}$ ,  $I_{D3} = 600\text{ mA}$ ,  $T_A = 25^\circ\text{C}$**

**Small Signal Gain**

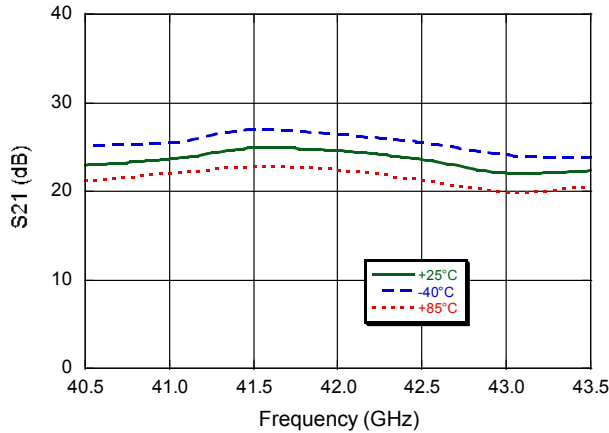

**Input Return Loss**

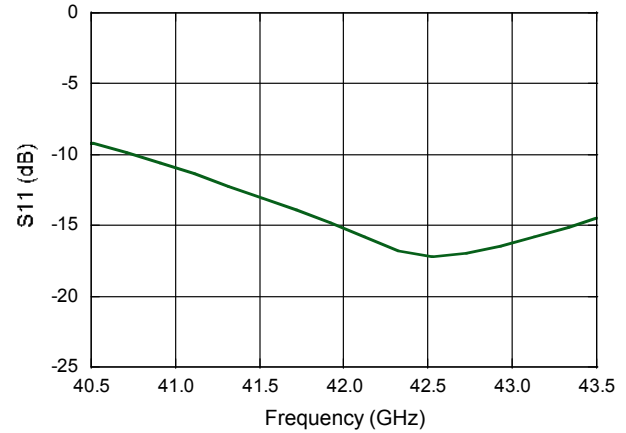

**Output Return Loss**

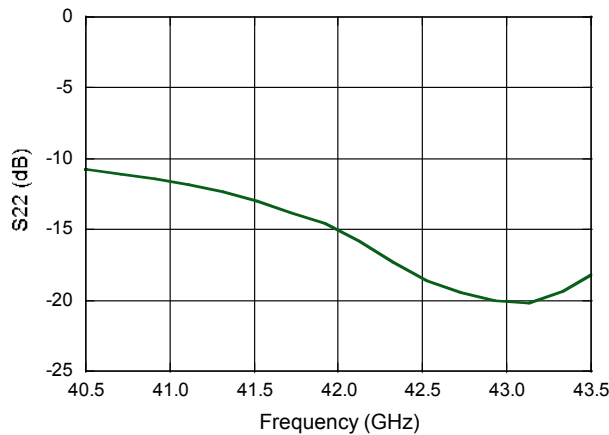

**Reverse Isolation**

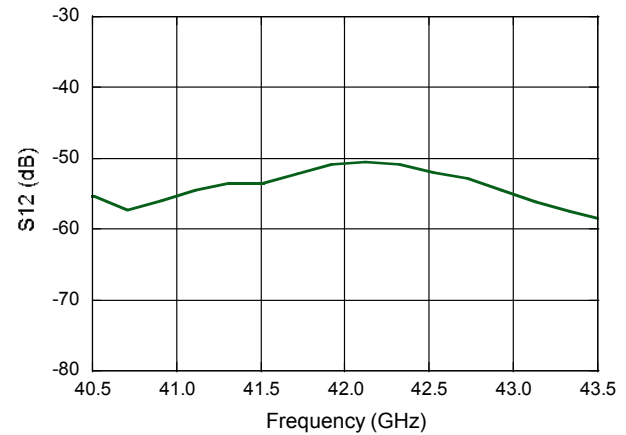

**Output IP3 (Pout = 14 dBm SCL)**

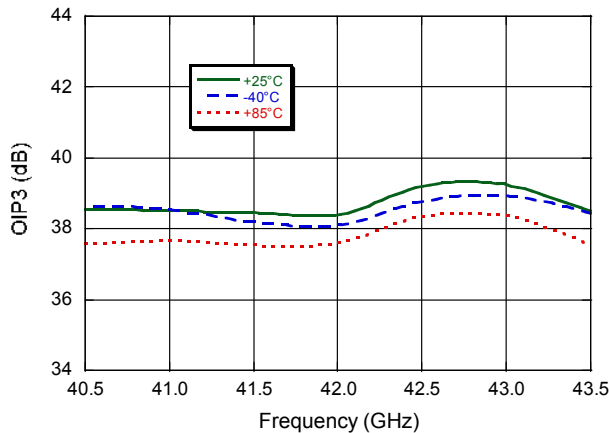

**C/13 (Pout = 14 dBm SCL)**

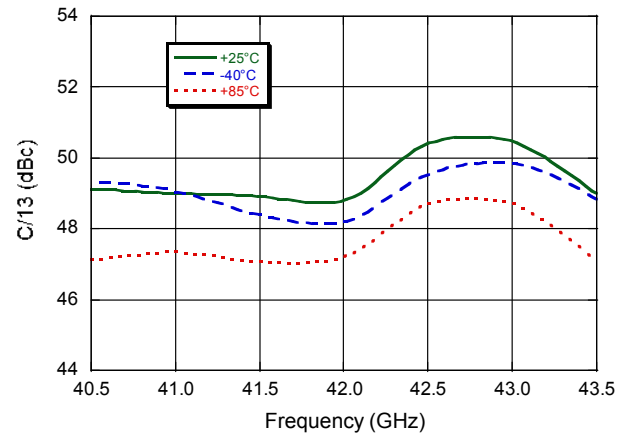

**ADVANCED:** Data Sheets contain information regarding a product M/A-COM Technology Solutions is considering for development. Performance is based on target specifications, simulated results, and/or prototype measurements. Commitment to develop is not guaranteed.  
**PRELIMINARY:** Data Sheets contain information regarding a product M/A-COM Technology Solutions has under development. Performance is based on engineering tests. Specifications are typical. Mechanical outline has been fixed. Engineering samples and/or test data may be available. Commitment to produce in volume is not guaranteed.

• **North America** Tel: 800.366.2266 • **Europe** Tel: +353.21.244.6400  
 • **India** Tel: +91.80.43537383 • **China** Tel: +86.21.2407.1588  
 Visit [www.macomtech.com](http://www.macomtech.com) for additional data sheets and product information.

M/A-COM Technology Solutions Inc. and its affiliates reserve the right to make changes to the product(s) or information contained herein without notice.

**Amplifier, Power, 0.8 W  
40.5 - 43.5 GHz**

V2

**Typical Performance Curves:  $V_D = 4\text{ V}$ ,  $I_{D1} = 217\text{ mA}$ ,  $I_{D2} = 300\text{ mA}$ ,  $I_{D3} = 600\text{ mA}$ ,  $T_A = 25^\circ\text{C}$**

**P1dB**

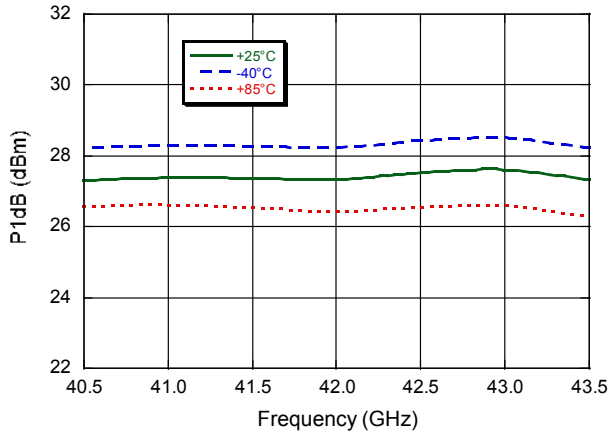

**Psat**

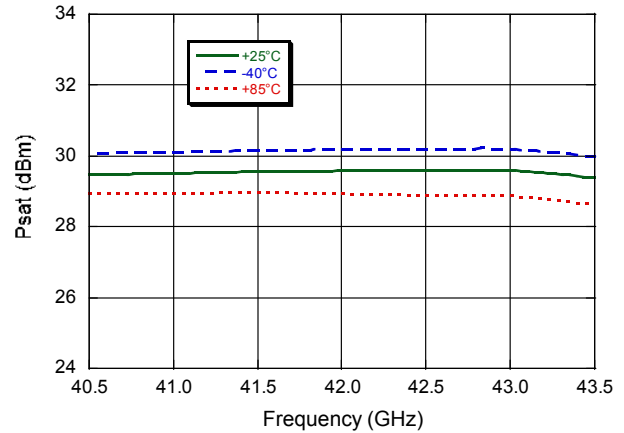

**Detector Output (Diff),  $V_{det/ref}\text{ Bias} = +5\text{V}100\text{k}$**

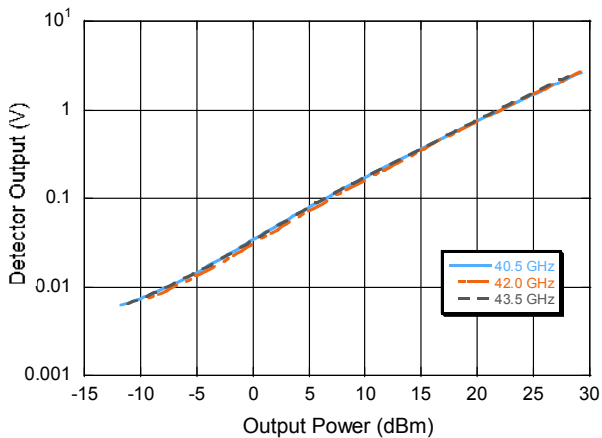

## Amplifier, Power, 0.8 W 40.5 - 43.5 GHz

V2

**App Note [1] Biasing** - It is recommended to bias the amplifier with  $V_d=4.0$  V and  $I_d=1117$  mA. It is also recommended to use active biasing to keep the currents constant as the RF power and temperature vary; this gives the most reproducible results. Depending on the supply voltage available and the power dissipation constraints, the bias circuit may be a single transistor or a low power operational amplifier, with a low value resistor in series with the drain supply used to sense the current. The gate of the pHEMT is controlled to maintain correct drain current and thus drain voltage. The typical gate voltage needed to do this is  $-0.3$ V. Typically the gate is protected with Silicon diodes to limit the applied voltage. Also, make sure to sequence the applied voltage to ensure negative gate bias is available before applying the positive drain supply.

**App Note [2] Bias Arrangement** - Each DC pin ( $V_{d1,2,3}$  and  $V_{g1,2,3}$ ) needs to have DC bypass capacitance ( $10$  nF/ $1$   $\mu$ F) as close to the package as possible.

**App Note [3] Power Detector** - As shown in the schematic below, the power detector is implemented by providing  $+5$  V bias and measuring the difference in output voltage with standard op-amp in a differential mode configuration.

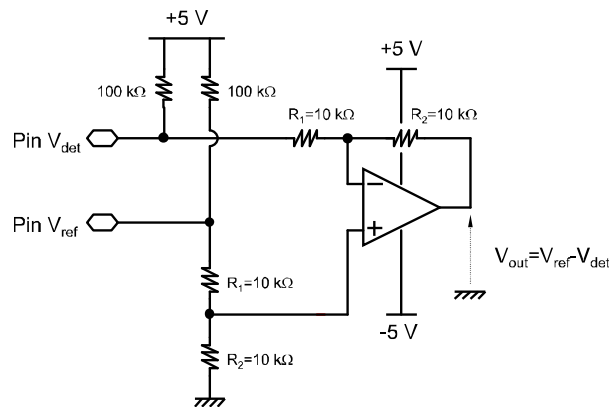

### Recommended Board Layout

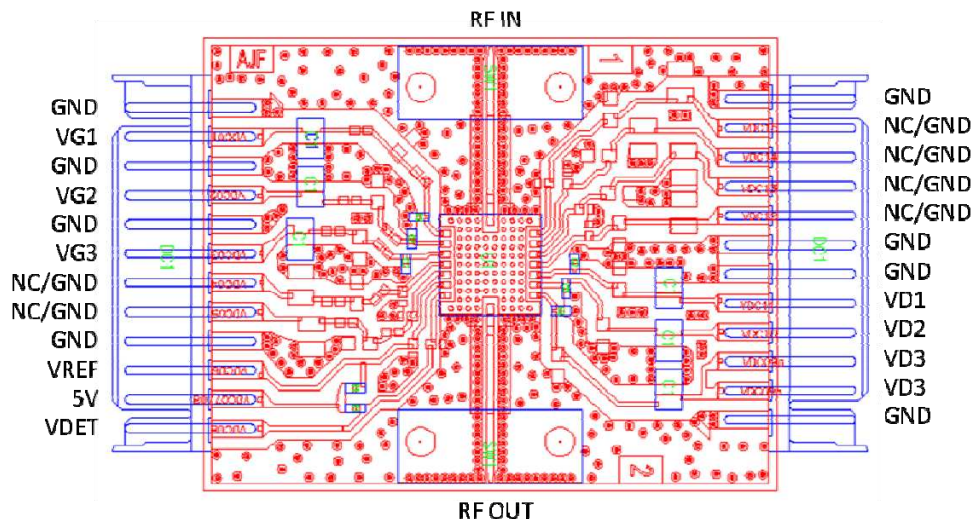

# MAAP-010512

Amplifier, Power, 0.8 W  
40.5 - 43.5 GHz

V2

## Lead-Free 7 mm x 7mm Laminate Package<sup>†</sup>

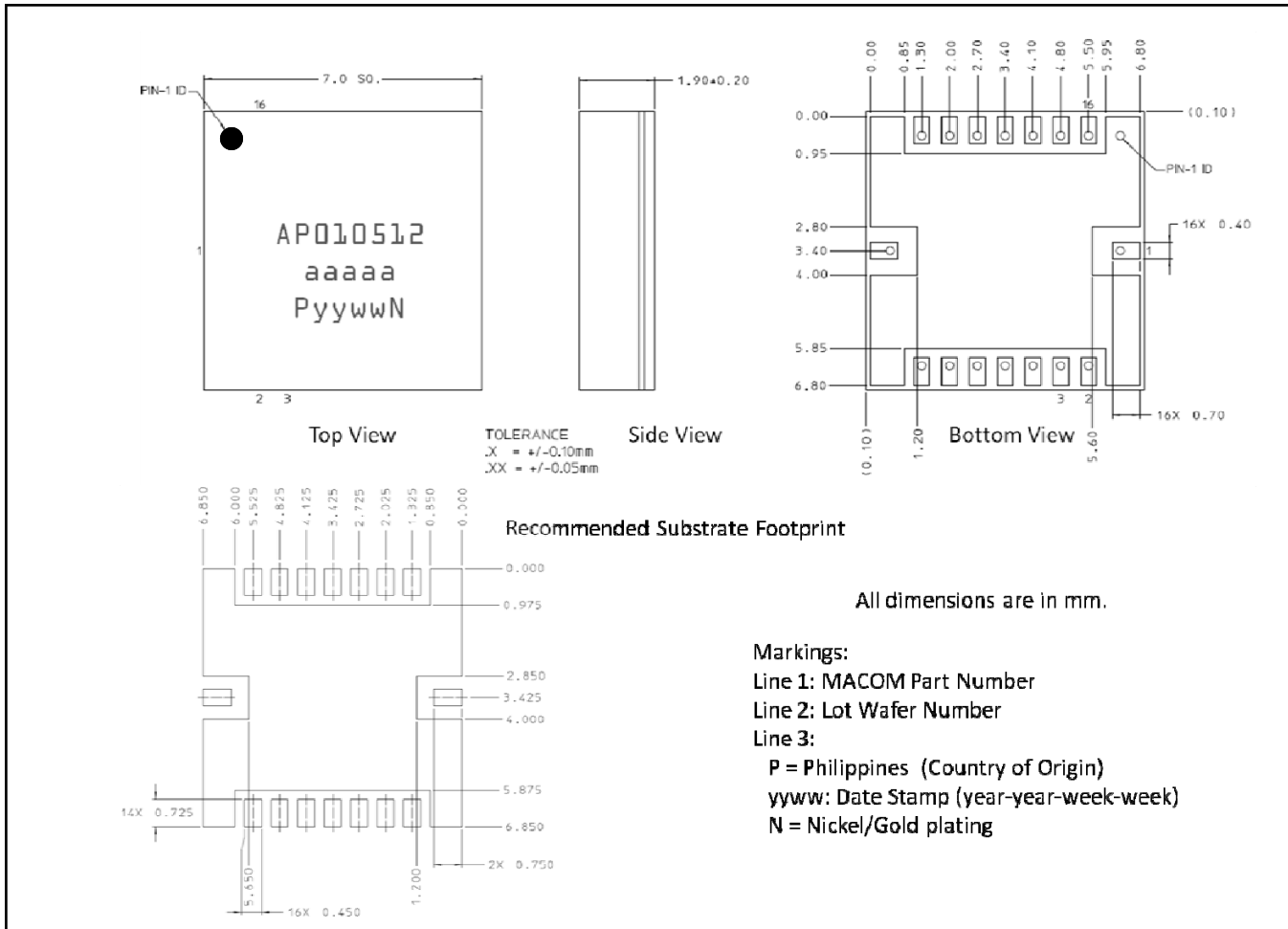

<sup>†</sup> Reference Application Note S2083 for lead-free solder reflow recommendations.  
Meets JEDEC moisture sensitivity level 3 requirements.