

# AT-107-PIN

**Digital Attenuator**  
**31.5 dB, 6-Bit, TTL Driver, DC-2.0 GHz**

Rev. V9

## Features

- Attenuation: 0.5 dB steps to 31.5 dB
- Temperature Stability:  $\pm 0.18$  dB from  $-55^{\circ}\text{C}$  to  $+85^{\circ}\text{C}$  Typical
- Low DC Power Consumption
- Hermetic Surface Mount Package
- Integral TTL Driver
- 50 Ohm Nominal Impedance
- Lead-Free CR-13 Package
- $260^{\circ}\text{C}$  Reflow Compatible
- RoHS\* Compliant

## Description

M/A-COM's AT-107-PIN is a GaAs FET 6-bit digital attenuator with a 0.5 dB minimum step size and 31.5 dB total attenuation. This attenuator and integral TTL driver is in a hermetically sealed ceramic 24-lead surface mount package. The AT-107-PIN is ideally suited for use where accuracy, fast switching, very low power consumption and low intermodulation products are required. Typical applications include dynamic range setting in precision receiver circuits and other gain/leveling control circuits. Environmental screening is available. Contact the factory for information.

## Ordering Information

Part Number	Package
AT-107-PIN	Bulk Packaging
AT-107-TB	Sample Test Board

Note: Reference Application Note M513 for reel size information.

## Functional Schematic

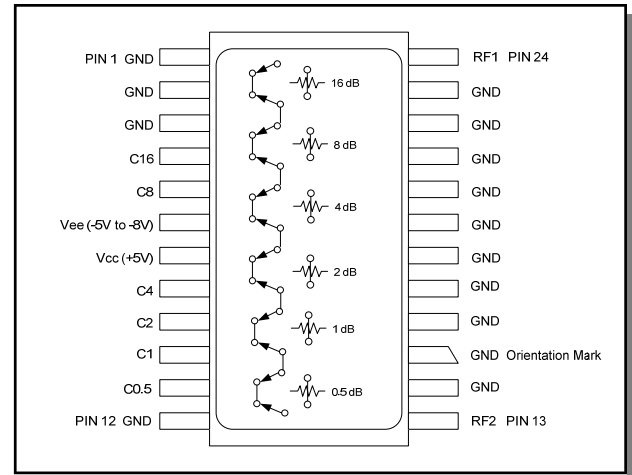

## Pin Configuration

Pin No.	Function	Pin No.	Function
1	GND	13	RF2
2	GND	14	GND
3	GND	15	GND
4	C16	16	GND
5	C8	17	GND
6	Vee (-5V to -8V)	18	GND
7	Vcc (+5V)	19	GND
8	C4	20	GND
9	C2	21	GND
10	C1	22	GND
11	C0.5	23	GND
12	GND	24	RF1

The metal bottom of the case must be connected to RF and DC ground.

\* Restrictions on Hazardous Substances, European Union Directive 2002/95/EC.

# AT-107-PIN



## Digital Attenuator 31.5 dB, 6-Bit, TTL Driver, DC-2.0 GHz

Rev. V9

### Electrical Specifications: $T_A = -55^\circ\text{C}$ to $+85^\circ\text{C}$ <sup>1</sup>

Parameter	Test Conditions	Frequency	Units	Min	Typ	Max
Reference Insertion Loss	—	DC - 0.5 GHz	dB	—	—	3.2
		DC - 1.0 GHz	dB	—	—	3.6
		DC - 2.0 GHz	dB	—	—	4.0
Attenuation Accuracy <sup>2</sup>	Any Single Bit	DC - 1.0 GHz	± (0.15 +3% of atten. setting in dB) dB			
	Any Combination of Bits	DC - 2.0 GHz	± (0.2 +3% of atten. setting in dB) dB			
		DC - 1.0 GHz	± (0.2 +3% of atten. setting in dB) dB or ± 0.4 dB, whichever is greater			
		DC - 2.0 GHz	± (0.2 +3% of atten. setting in dB) dB or ± 0.4 dB, whichever is greater			
VSWR	—	DC - 2.0 GHz	Ratio	—	—	1.8:1
Trise, Tfall	10% to 90%	—	ns	—	9	—
Ton, Toff	50% Control to 90/10% RF	—	ns	—	45	—
Transients	In-Band (peak-peak)	—	mV	—	40	—
1 dB Compression	Input Power	0.05 GHz	dBm	—	+21	—
		0.5 - 2.0 GHz	dBm	—	+29	—
Input IP3	For two-tone Input Power Up to +5 dBm	0.05 GHz	dBm	—	+35	—
		0.5 - 2.0 GHz	dBm	—	+48	—
Input IP2	For two-tone Input Power Up to +5 dBm	0.05 GHz	dBm	—	+45	—
		0.5 - 2.0 GHz	dBm	—	+79	—
Vcc	—	—	V	4.5	5.0	5.5
Vee	—	—	V	-8.0	—	-5.0
Icc	Vcc = 4.5 to 5.5V Vctl = 0 to 0.8V, or Vcc – 2.1V to Vcc	—	mA	—	—	6.0
Iee	Vee = -5.0 to -8.0V	—	mA	—	—	1.0
Vctl Vcti	Logic 0 (TTL)	—	V	0.0	—	0.8
	Logic 1 (TTL)	—	V	2.0	—	5.0
Input Leakage Current (Low)	0 to 0.8V	—	µA	—	—	1.0
Input Leakage Current (High)	2.0 to 5.0V	—	µA	—	—	1.0

1. All specifications apply when operated with bias voltages of +5V for Vcc and –5.0V for Vee.
2. This attenuator is guaranteed monotonic.

## Absolute Maximum Ratings <sup>3,4</sup>

Parameter	Absolute Maximum
Max Input Power 0.05 GHz 0.5 - 2.0 GHz	+27 dBm +34 dBm
$V_{CC}$	$-0.5V \leq V_{CC} \leq +7.0V$
$V_{EE}$	$-8.5V \leq V_{EE} \leq +0.5V$
$V_{CC} - V_{EE}$	$-0.5V \leq V_{CC} - V_{EE} \leq 14.5V$
$V_{in}^5$	$-0.5V \leq V_{in} \leq V_{CC} + 0.5V$
Operating Temperature	$-55^{\circ}C$ to $+125^{\circ}C$
Storage Temperature	$-65^{\circ}C$ to $+150^{\circ}C$

- Exceeding any one or combination of these limits may cause permanent damage to this device.
- M/A-COM does not recommend sustained operation near these survivability limits.
- Standard CMOS TTL interface, latch-up will occur if logic signal is applied prior to power supply.

## Handling Procedures

Please observe the following precautions to avoid damage:

## Static Sensitivity

Gallium Arsenide Integrated Circuits are sensitive to electrostatic discharge (ESD) and can be damaged by static electricity. Proper ESD control techniques should be used when handling these devices.

## Typical Performance Curves

### Insertion Loss vs. Frequency

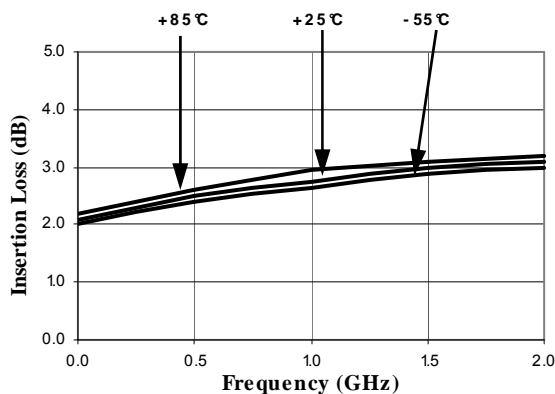

## Recommended PCB Configuration

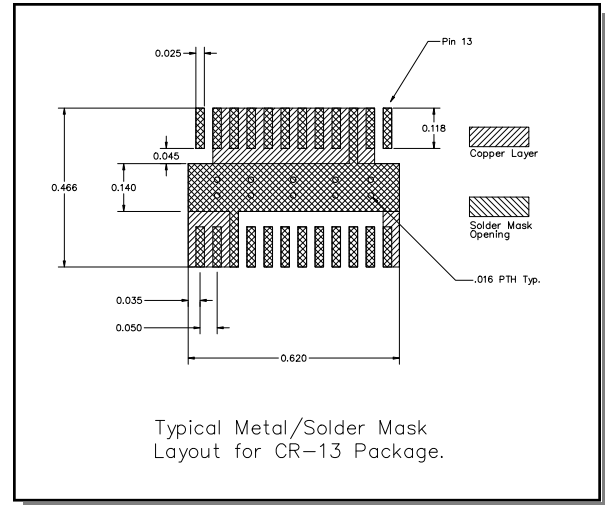

## Truth Table (Digital Attenuator)

Control Inputs						Attenuation
C6	C5	C4	C3	C2	C1	
0	0	0	0	0	0	Reference
0	0	0	0	0	1	0.5 dB
0	0	0	0	1	0	1 dB
0	0	0	1	0	0	2 dB
0	0	1	0	0	0	4 dB
0	1	0	0	0	0	8 dB
1	0	0	0	0	0	16 dB
1	1	1	1	1	1	31.5 dB

0 = TTL Low; 1 = TTL High

### Attenuation Accuracy vs. Frequency

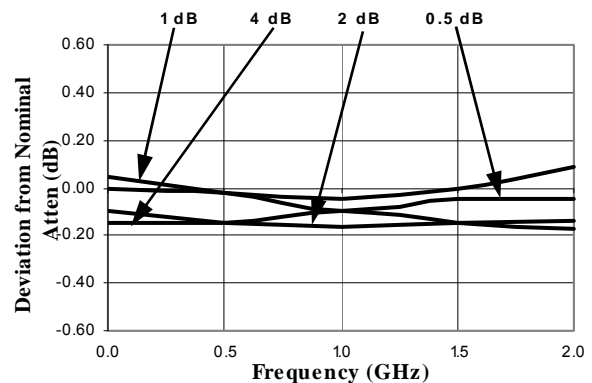

# AT-107-PIN

**Digital Attenuator**  
**31.5 dB, 6-Bit, TTL Driver, DC-2.0 GHz**

Rev. V9

## Typical Performance Curves

*Attenuation Accuracy vs. Frequency*

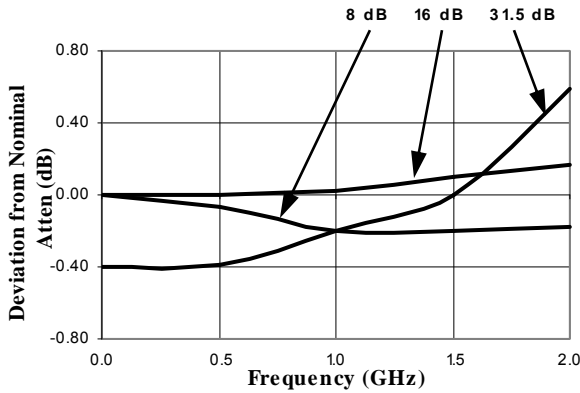

*RF1 VSWR vs. Frequency*

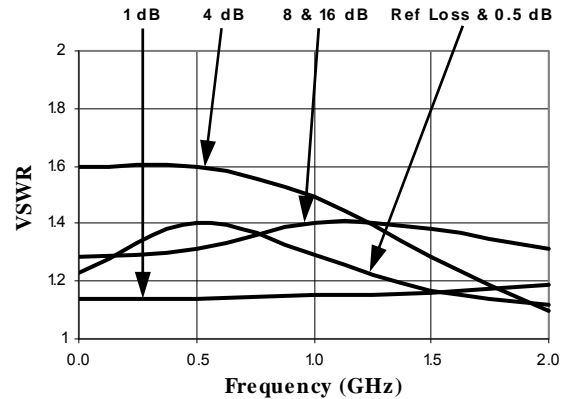

*RF2 VSWR vs. Frequency*

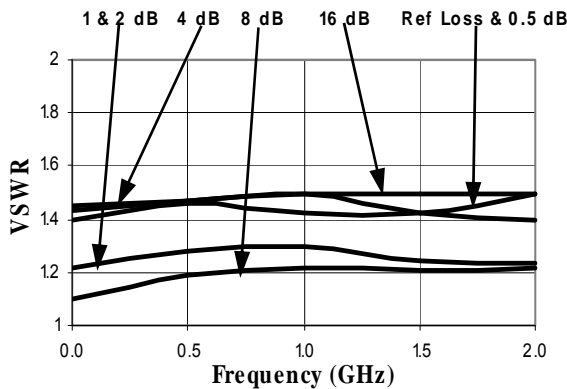

*Lead-Free, CR-13 Ceramic Package†*

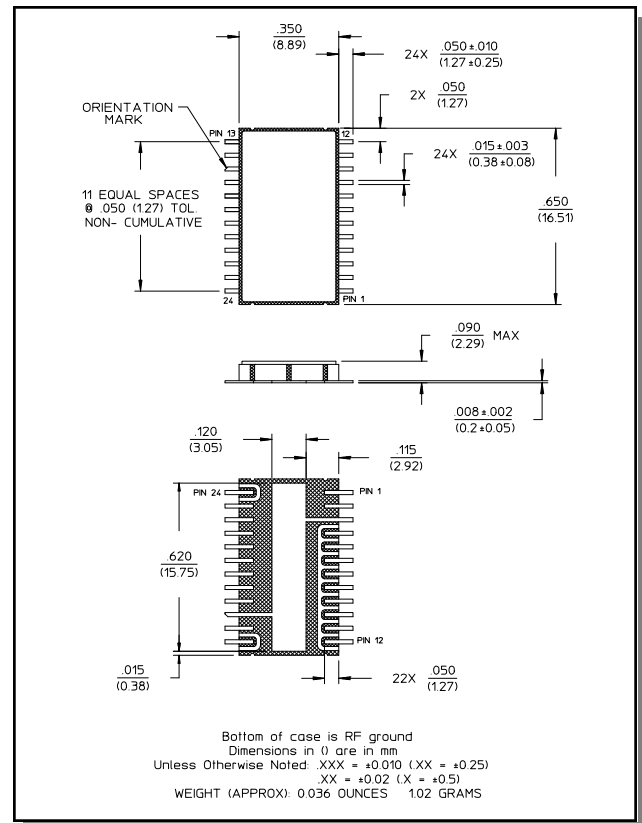

† Reference Application Note M538 for lead-free solder reflow recommendations.