

Features

- Attenuation: 16 dB steps to 32 dB
- Temperature Stability: ± 0.18 dB from -40°C to $+85^{\circ}\text{C}$ Typical
- Low DC Power Consumption
- Surface Mount Package
- Integral TTL Driver
- Low Cost/High Performance
- 50 Ohm Nominal Impedance
- Lead-Free CR-11 Package
- 260°C Reflow Compatible
- RoHS* Compliant

Description

M/A-COM's AT20-0273 is a GaAs FET digital attenuator with a 16 dB minimum step size and 32 dB total attenuation. This attenuator and integral TTL driver is in a sealed ceramic 16-lead surface mount package. The AT20-0273 is ideally suited for use where accuracy, fast switching, very low power consumption and low intermodulation products are required. Typical applications include dynamic range setting in precision receiver circuits and other gain/leveling control circuits. Available with enhanced performance as fully hermetic version. Environmentally screenable as P/N AT-273-PIN.

Ordering Information

Part Number	Package
AT20-0273	Bulk Packaging

Note: Reference Application Note M513 for reel size information.

Functional Schematic¹

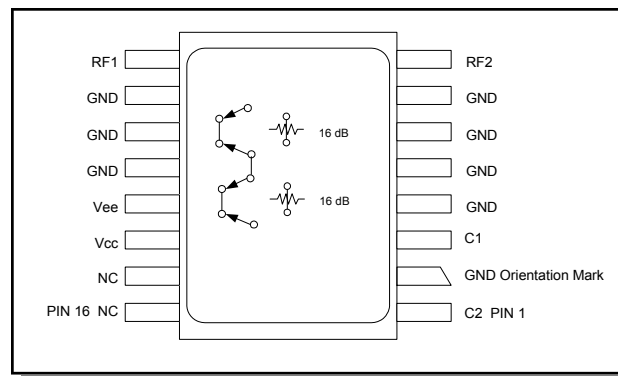

1. Use the C1 control for a single 16-dB bit.

Pin Configuration

Pin No.	Function	Pin No.	Function
1	C2	9	RF1
2	GND	10	GND
3	C1	11	GND
4	GND	12	GND
5	GND	13	Vee
6	GND	14	Vcc
7	GND	15	NC
8	RF2	16	NC

The metal bottom of the case must be connected to RF and DC ground.

* Restrictions on Hazardous Substances, European Union Directive 2002/95/EC.

Digital Attenuator 32.0 dB, 2-Bit, TTL Driver, DC-2.0 GHz

Rev. V6

Electrical Specifications: $T_A = 25^\circ\text{C}$ ²

Parameter	Test Conditions	Frequency	Units	Min	Typ	Max
Reference Insertion Loss	—	DC - 0.5 GHz	dB	—	1.2	1.6
		DC - 1.0 GHz	dB	—	1.3	1.7
		DC - 2.0 GHz	dB	—	1.5	1.9
Attenuation Accuracy ³	C1 Bit Full Attenuation (32 dB)	DC - 2.0 GHz DC - 0.5 GHz DC - 1.0 GHz DC - 2.0 GHz		$\pm 3\%$ of attenuation setting in dB $\pm 3\%$ of attenuation setting in dB $\pm 3\%$ of attenuation setting in dB, -1 dB $\pm 3\%$ of attenuation setting in dB, -3 dB		
VSWR	—	DC - 2.0 GHz	Ratio	—	—	1.4:1
Trise, Tfall	10% to 90%	—	ns	—	50	—
Ton, Toff	50% Control to 90/10% RF	—	ns	—	150	—
Transients	In-Band (peak-peak)	—	mV	—	50	—
1 dB Compression	Input Power Input Power	0.05 GHz	dBm	—	+20	—
		0.5 - 2.0 GHz	dBm	—	+28	—
Input IP3	For two-tone Input Power Up to +5 dBm	0.05 GHz	dBm	—	+38	—
		0.5 - 2.0 GHz	dBm	—	+48	—
Input IP2	For two-tone Input Power Up to +5 dBm	0.05 GHz	dBm	—	+44	—
		0.5 - 2.0 GHz	dBm	—	+68	—
Vcc	—	—	V	4.5	5.0	5.5
Vee	—	—	V	-8.0	—	-5.0
Icc	Vcc = 4.5 to 5.5V Vctl = 0 to 0.8V, or Vcc -2.1V to Vcc	—	mA	—	—	2.0
Iee	Vee = -5.0 to -8.0V	—	mA	—	—	1.0

- All specifications apply when operated with bias voltages of +5V for Vcc and -5.0V for Vee.
- This attenuator is guaranteed monotonic.

Absolute Maximum Ratings^{4,5}

Parameter	Absolute Maximum
Max Input Power 0.5 GHz 0.5 - 2.0 GHz	+27 dBm +34 dBm
V _{CC}	-0.5V ≤ V _{CC} ≤ +7.0V
V _{EE}	-8.5V ≤ V _{EE} ≤ +0.5V
V _{CC} - V _{EE}	-0.5V ≤ V _{CC} - V _{EE} ≤ 14.5V
V _{in} ⁶	-0.5V ≤ V _{in} ≤ V _{CC} + 0.5V
Operating Temperature	-40°C to +125°C
Storage Temperature	-65°C to +150°C

- Exceeding any one or combination of these limits may cause permanent damage to this device.
- M/A-COM does not recommend sustained operation near these survivability limits.
- Standard CMOS TTL interface, latch-up will occur if logic signal is applied prior to power supply.

Handling Procedures

Please observe the following precautions to avoid damage:

Static Sensitivity

Gallium Arsenide Integrated Circuits are sensitive to electrostatic discharge (ESD) and can be damaged by static electricity. Proper ESD control techniques should be used when handling these devices.

Truth Table (Digital Attenuator)

Control Input		
C2	C1	Attenuation
0	0	Reference
0	1	16 dB
1	1	32 dB

0 = TTL Low; 1 = TTL High

Typical Performance Curves

Ref. Insertion Loss vs. Frequency

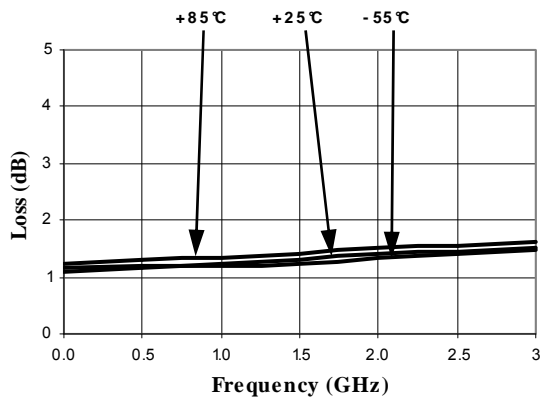

Attenuation Accuracy vs. Frequency

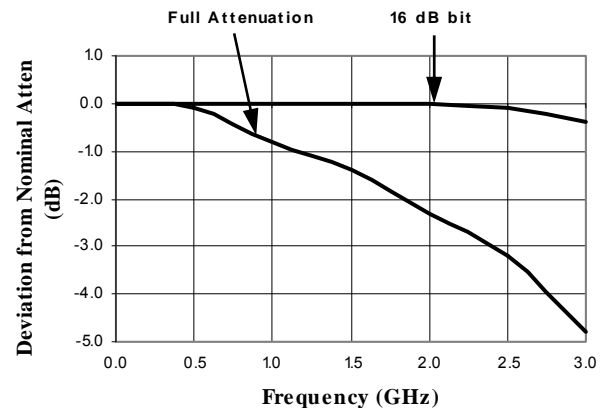

VSWR vs. Frequency

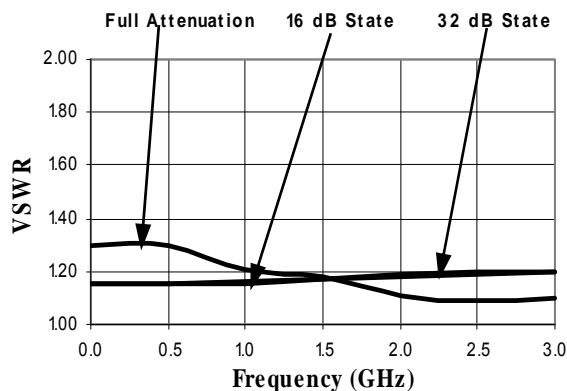

AT20-0273

Digital Attenuator
32.0 dB, 2-Bit, TTL Driver, DC-2.0 GHz

Rev. V6

Lead-Free, CR-11 Ceramic Package†

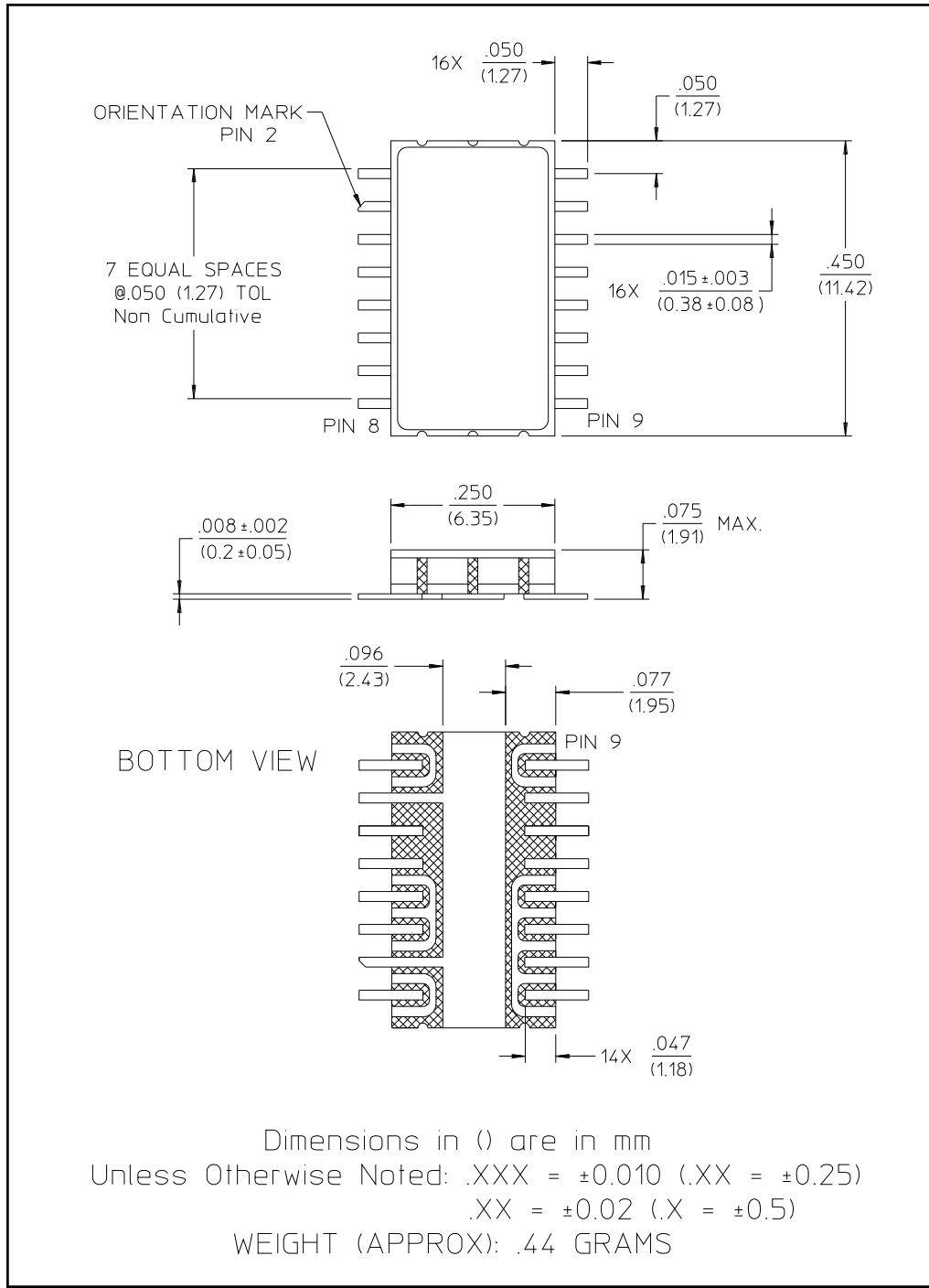

† Reference Application Note M538 for lead-free solder reflow recommendations.