

Applications

- Distributed power architectures
- Telecommunications equipment
- LAN/WAN
- Data processing

Features

- RoHS lead solder exemption compliant
- Low profile – 12.7 mm height
- Input/output isolation: 1500 VDC
- Basic insulation
- High efficiency - up to 88% at full load
- Start-up into high capacitive load
- Low conducted and radiated EMI
- Output overcurrent protection
- Output overvoltage protection
- Back-drive protection
- Overtemperature protection
- Remote sense
- Remote on/off (primary referenced), positive or negative logic
- Output voltage trim adjust
- UL60950-3rd/ CSA C22.2 60950-00, TUV EN60950-1, IEC60950-1

Description

The HHS40 is a series of high efficiency, high-density, single output dc-dc converters for onboard conversion of standard telecom and datacom input voltages into isolated low voltage outputs in a through-hole mounting package. The two-board construction provides a cool environment for control components and the integrated metal substrate PCB provides superior thermal management for power components resulting in enhanced product reliability. A heat sink can be conveniently and effectively attached to the IMS base plate for operations in elevated ambient conditions or where airflow is minimal.

Model Selection						
Model	Input Voltage VDC	Input Current, Max ² ADC	Output Voltage Vout, VDC	Output Rated Current I_{rated}, ADC	Output Ripple/Noise, mV p-p	Typical Efficiency @ I_{rated}, %
HHS40ZE	36 -75	4.5	3.3	40	150	88
HHS40ZD ¹	36 -75	3.6	2.5	40	150	88

NOTES:

¹ Consult factory for availability

² @ Vin min.



Absolute Maximum Ratings

Stresses in excess of the absolute maximum ratings may cause performance degradation, adversely effect long-term reliability, and cause permanent damage to the converter.

Table 1. Absolute Maximum Ratings

Parameter	Conditions/Description	Min	Max	Units
Input voltage	Continuous		75	VDC
	Transient (100 ms)		100	VDC
Operating Temperature	Baseplate	-40	115	°C
Storage Temperature	Ambient	-55	125	°C
ON/OFF Control Voltage	Referenced to -Vin		10	VDC

Environmental, Mechanical & Reliability Specifications

All specifications apply over specified input voltage, output load, and temperature range, unless otherwise noted.

Table 2. Environmental and Mechanical Specifications

Parameter	Conditions/Description	Min	Nom	Max	Units
Operating Temperature	Baseplate Temperature	-40		115	°C
Operating Humidity	Relative humidity, non-condensing			95	%
Storage Humidity	Relative humidity, non-condensing			95	%
Shock	Halfsine wave (6ms), 3 axes	50			g
Sinusoidal Vibration	GR-63-CORE, Section 5.4.2	1			g
Weight			1.9/54		Oz/g
Water Washing	Standard process		Yes		
MTBF (calculated)	Per Bellcore TR-NWT-000332 (Po=60W, Tc=40 °C)		1,500		kHrs
Dimensions	(overall)		2.28(57.9) x 2.4(61) x 0.5(12.7)		in (mm)

Isolation Specifications

All specifications apply over specified input voltage, output load, and temperature range, unless otherwise noted.

Table 3. Isolation Specifications

Parameter	Conditions/Description	Min	Nom	Max	Units
Insulation Safety Rating		Basic			
Isolation Voltage	Input to output, input to base plate	1500			VDC
	Output to base plate	707			VDC
Isolation Resistance		10			MΩ
Isolation Capacitance	Input to Output		1000		pF

Safety Regulatory Compliance

Safety Agency	Standard Approved To:	Marking
Underwriters Laboratories	UL60950/CSA60950-00	cULus
TUV product Service	TUV EN60950:2000	TUV PS Baurt mark
CB report	IEC60950:1999	N/A.

Input Specifications

All specifications apply over specified input voltage, output load, and temperature range, unless otherwise noted.

Table 4. Input Specifications

Parameter	Conditions/Description	Min	Nom	Max	Units
Input Voltage	Continuous	36	48	75	VDC
Turn-On Input Voltage ¹	Ramping Up	32.5	34	35.5	VDC
Turn-Off Input Voltage ¹	Ramping Down	31.5	33	34.5	VDC
Input over voltage protection	Ramping up	76		84	VDC
Input Reflected Ripple Current ²	Full Load, 12 μH source inductance			50	mA p-p
Inrush Transient	Vin = Vin.max			1.0	A ² s

¹ Refer to Figures 3 & 4 for actual characteristic waveforms.

² Refer to Figure 10 for test circuit.

Output Specifications

All specifications apply over specified input voltage, output load, and temperature range, unless otherwise noted.

Table 5. Output Specifications

Parameter	Conditions/Description	Min	Nom	Max	Units	
Output Voltage Setpoint Accuracy	2.5V	-2.00		2.00	%Vout	
	3.3V	-1.5		1.5	%Vout	
Output Current ¹	I _{rated}	0.5		40	Amps	
Line Regulation	V _{in.min} to V _{in.max} , I _{rated}		.25	.5	%Vout	
Load Regulation	V _{in} = V _{in.nom} , 10% to 100%I _{rated}		.5	1	%Vout	
Output Temperature Regulation	(T _{Baseplate}) = -40 °C to +115 °C)			0.03	%/°C	
Remote Sense Headroom ³				10	%Vout	
Ripple and Noise, DC to 20MHz ^{1,5}	Over line and load T _{amb} = 0 °C to 85 °C		125	150	mV p-p	
			35	60	mV _{RMS}	
Dynamic Regulation	75-100-75% load step change, to 1% error band di/dt = 0.1A/μs		8	13	%Vout	
		Peak Deviation	200	300	μs	
		Settling Time				
		Peak Deviation				
Turn-On Time (turn-on via application of V _{in})	Time from V _{in} = UVLO to regulation band		7	15	ms	
		Settling Time				
Turn-On Time (turn-on via ON/OFF signal)	Time from ON/OFF signal to regulation band		5	10	ms	
		Settling Time				
Admissible Load Capacitance	I _{rated} , Nom V _{in}			13,000	μF	
Output Current Limit Threshold ²	V _{ou} ≤ 0.97V _{out.nom}	110		150	%I _{rated}	
Short Circuit ²	Hiccup		9	14	A _{RMS}	
Turn-On Overshoot			1	5	%Vout	
Backdrive Protection	No damage to converter		Yes			
Switching Frequency			300		kHz	
Overvoltage Protection, Clamp, Non Latching	Over all input voltage and load conditions	120		140	%Vout	
Trim Range ³	I _{rated} , V _{in} = V _{nom}	90		110	%Vout	

¹ At I_{out} < I_{out.min}, the output may contain low frequency component that exceeds ripple specifications.

² Overcurrent protection is non-latching with auto recovery.

³* V_{out} can be increased up to 10% via the sense leads or up to 10% via the trim function, however total output voltage trim from all sources should not exceed 10% of V_{out}

⁴ Adding output capacitance will have a significant effect in reducing the peak amplitude deviation when powering fast slew-rate loads.

⁵ Refer to Figure 11 for test circuit.

Feature Specifications

All specifications apply over specified input voltage, output load, and temperature range, unless otherwise noted.

Table 6. Feature Specifications

Parameter	Conditions/Description	Min	Nom	Max	Units
Shutdown (ON/OFF) Negative Logic (-N suffix)	ON/OFF signal is low or the pin is connected to -Vin – converter is ON				
Converter ON	Von/off in reference to -Vin	-0.5		1.8	VDC
Source Current	ON/OFF pin is connected to -Vin		0.5	1	mADC
Converter OFF	Von/off in reference to -Vin	2.5		10	VDC
Open Circuit Voltage	ON/OFF pin is floating			5	VDC
Shutdown (ON/OFF) Positive Logic (Std. model)	On/Off signal is low or the pin is floating –converter is OFF				
Converter ON	Von/off in reference to -Vin	2.5		10	VDC
Open Circuit Voltage	ON/OFF pin is floating			5	VDC
Converter OFF	Von/off in reference to -Vin	-0.5		1.8	VDC
Source Current	ON/OFF pin is connected to -Vin		0.5	1	mADC
Overtemperature Protection	Baseplate temperature	120	125	130	°C

Characteristic Curves

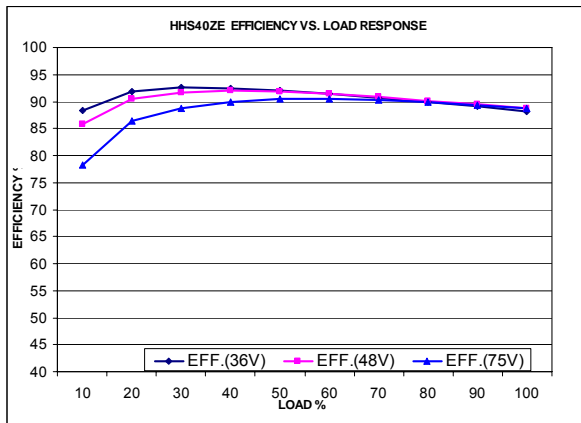

Figure 1. HHS40ZE Efficiency vs. Output Load

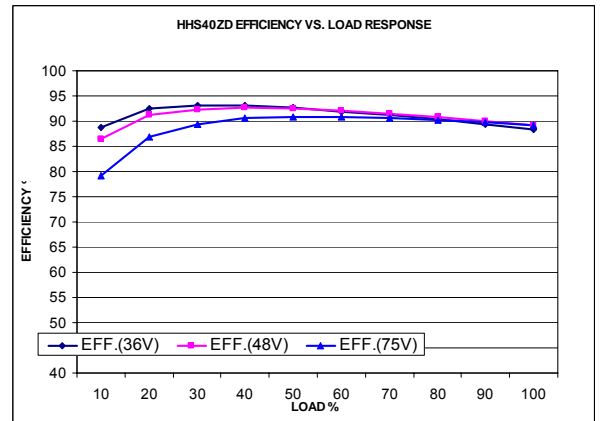

Figure 2. HHS40ZD Efficiency vs. Output Load

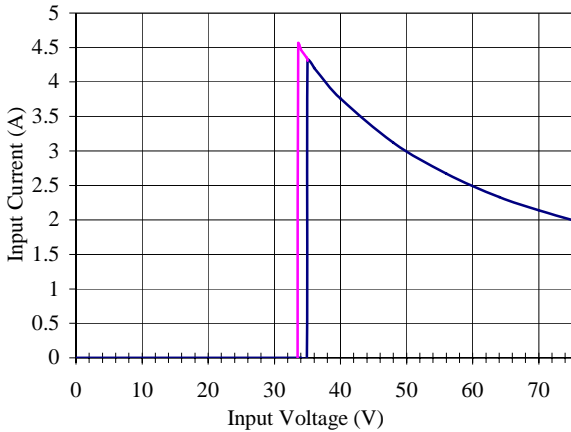

Figure 3. HHS40ZE Input Characteristics

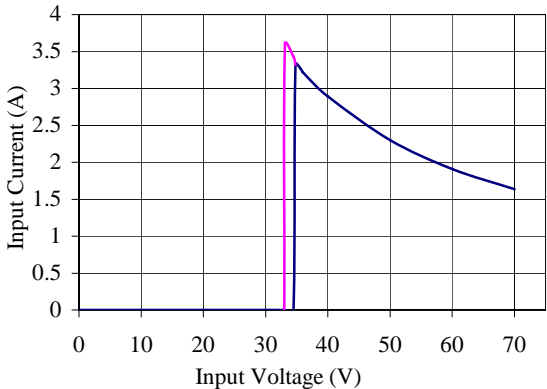

Figure 4. HHS40ZD Input Characteristics

Typical Application

Figure 5 shows the recommended connections for the HHS40 Series converter.

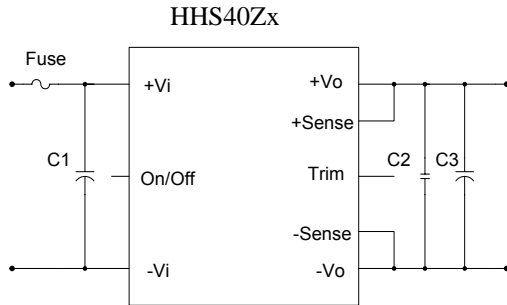

Figure 5. Typical Application of the HHS40 Series

These converter modules do not require any external components for proper operation. However, if the distribution of the input voltage to the converter contains significant inductance, the capacitor C1 may be required to enhance performance of the converter. A minimum of a 68 μF electrolytic capacitor with the $\text{ESR} < 0.7\Omega$ is recommended for the HHS40 Series.

Refer to the “Inrush Current Control Application Note” on www.power-one.com for suggestions on how to limit the magnitude of the inrush current.

For output decoupling we recommend to use a 10 μF tantalum and a 0.1 μF ceramic capacitors connected directly across the output pins of the converter. Note, that the capacitors do not substitute the filtering required by the load.

Shutdown Feature Description

The ON/OFF (# 3) pin of the HHS40 Series converters are referenced to the -Vin (# 1) pin (see Figure 5). Both negative and positive logic models are available.

With negative logic (which is denoted by the suffix “-N” in the part number), when the ON/OFF pin is pulled low, the unit is turned on.

With the positive logic, when the ON/OFF pin is pulled low, the output is turned off and the unit goes into a very low input power mode.

An open collector switch is recommended to control the voltage between the ON/OFF pin and the -Vin pin of the converter. The ON/OFF pin is pulled up internally, so no external voltage source is required.

The user should avoid connecting a resistor between the ON/OFF pin and the +Vin (# 4) pin.

When the ON/OFF pin is used to achieve remote control, the user must take care to insure that the pin reference for the control is actually the -Vin pin. The control signal must not be referenced ahead of EMI filtering, or remotely from the unit. Optically coupling the information and locating the optical coupler directly at the module will solve any of these problems.

Note:

If the ON/OFF pin is not used, it can be left floating (positive logic), or connected to the -Vin pin (negative logic).

Remote Sense

The HHS40 Series converters have the capability to remotely sense both lines of the output. This feature moves the effective output voltage regulation point from the output of the unit to the point of connection of the remote sense pins. This feature automatically adjusts the real output voltage of the converter in order to compensate for voltage drops in distribution and maintain a regulated voltage at the point of load. This is shown in Figures 6 & 7.

If the remote sense feature is not to be used, the sense pins should be connected locally. The +Sense (#8) pin should be connected to the +Vout (#9) pin directly at the output of the converter and the -Sense (#6) pin should be connected to the -Vout (#5) pin directly at the output of the converter.

If sense pins are not connected to load, or the respective output pins, the converter will not be damaged, but may not meet the output voltage regulation specifications.

OUTPUT VOLTAGE TRIM

Industry Standard (Positive) Trim (-T suffix)

The trim feature allows the user to adjust the output voltage from its nominal value.

The HHS40 positive-trim (-T) models trim up with a resistor from the Trim (#7) pin to the +Sense (#8) pin and trims down with a resistor from the Trim pin to the -Sense (#6) pin as shown in the Figure 6.

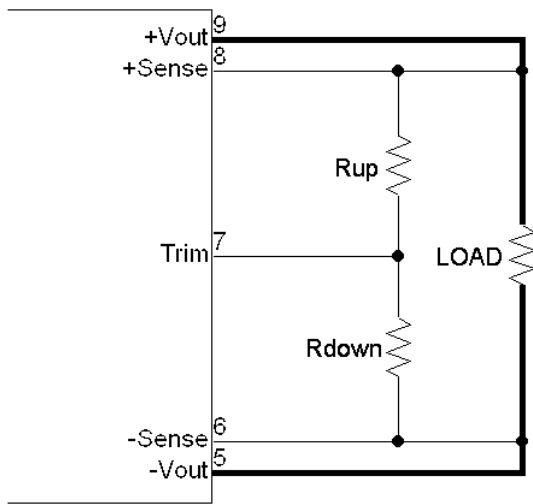

Figure 6. HHS40 Series Positive Trim (-T) Schematic

The equations below determine the trim resistor value required to achieve a ΔV change in the output voltage.

$$R_{adj-up} = \left(\frac{V_o(100 + \Delta\%)}{1.225\Delta\%} - \frac{100}{\Delta\%} - 2 \right) k\Omega$$

$$R_{adj-down} = \left(\frac{100}{\Delta\%} - 2 \right) k\Omega$$

where $\Delta V\%$ is the output voltage change expressed in percent of the nominal output voltage, V_{out} .

Negative-Trim Models (No P/N suffix)

All HHS40 negative-trim models trim up with a resistor connected from the TRIM (#7) pin to the (-) Sense (#6) pin and trim down with a resistor from the TRIM pin to the (+) Sense (#8) pin as shown in Figure 7.

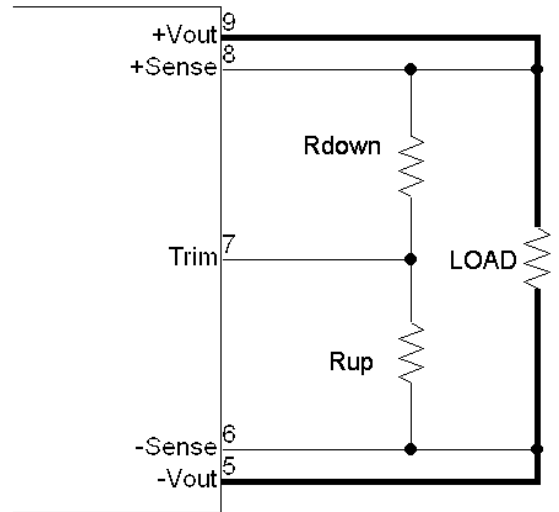

Figure 7. HLS Series Negative Trim Schematic

The following equation determines the required external resistor value to obtain an output voltage change of $\Delta\%$.

$$R_{adj-down} = \left(\frac{a^2}{a+b} \cdot \frac{100}{\Delta\%} - a - c \right) k\Omega$$

$$R_{adj-up} = \left(\frac{a \cdot b}{a+b} \cdot \frac{100}{\Delta\%} - c \right) k\Omega$$

Trim parameters for a, b & c are defined in the following table.

Model Name	a	b	c
HHS40ZD /-N	1.04	1.00	3.92
HHS40ZE /-N	1.69	1.00	3.92



Notes:

1. When the output voltage is trimmed up, the output power from the converter must not exceed its maximum rating. The power is determined by measuring the output voltage on the output pins, and multiplying it by the output current.
2. In order to avoid creating apparent load regulation degradation, it is important that the trim resistors are connected directly to the remote sense pins, and not to the load or to traces going to the load.
3. The output voltage increase can be accomplished by either the trim or by the remote sense or by the combination of both. In any case the absolute maximum output voltage increase shall not exceed the limits defined in section 6 above.
4. Either R_{up} or R_{down} should be used to adjust the output voltage according to the equations above. If both R_{up} and R_{down} are used simultaneously, they will form a resistive divider and the equations above will not apply

Safety Considerations

The HHS40 Series converters feature 1500 Volt DC isolation from input to output. The input-to-output resistance is greater than 10M Ω . These converters are provided with Basic insulation between input and output circuits according to all IEC60950 based standards. Nevertheless, if the system using the converter needs to receive safety agency approval, certain rules must be followed in the design of the system. In particular, all of the creepage and clearance requirements of the end-use safety requirements must be observed. These documents include UL60950 - CSA60950-00 and EN60950, although other or additional requirements may be needed for specific applications.

The HHS40 Series converters have no internal fuse. An external fuse must be provided to protect the system from catastrophic failure, as illustrated in figure 5. Refer to the "Input Fuse Selection for DC/DC converters" application note on www.power-one.com for proper selection of the input fuse. Both input traces and the chassis ground trace (if applicable) must be capable of conducting a current of 1.5 times the value of the fuse without opening. The fuse must not be placed in the grounded input line, if any.

In order for the output of the HHS40 Series converter to be considered as SELV (Safety Extra Low Voltage) or TNV-1, according to all IEC60950 based standards, one of the following requirements must be met in the system design:

- If the voltage source feeding the module is SELV or TNV-2, the output of the converter may be grounded or ungrounded.
- If the voltage source feeding the module is ELV, the output of the converter may be considered SELV

only if the output is grounded per the requirements of the standard.

- If the voltage source feeding the module is a Hazardous Voltage Secondary Circuit, the voltage source feeding the module must be provided with at least Basic insulation between the source to the converter and any hazardous voltages. The entire system, including the HHS40 converter, must pass a dielectric withstand test for Reinforced insulation. Design of this type of systems requires expert engineering and understanding of the overall safety requirements and should be performed by qualified personnel.

Thermal Considerations

The HHS40 Series converters are designed for natural or forced convection cooling. The maximum allowable output current of the converters is determined by meeting the derating criteria for all components used in the converters. For example, the maximum semiconductor junction temperature is not allowed to exceed 120 °C to ensure reliable long-term operation of the converters.

The graphs in Figures 8 & 9 show the maximum output current of the HHS40 Series converters at different ambient temperatures under both natural and forced convection. (longitudinal airflow direction, from pin 1 to pin 4).

For example, from Figure 8, the HHS40ZE operating at 55 °C can deliver up to 27 A reliably with 200 LFM forced air, while up to 36 A reliably with 400 LFM forced air.

Power Derating Characteristics

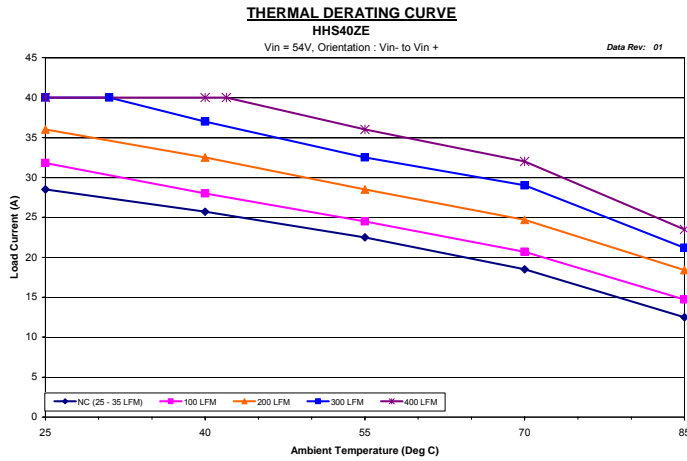

Figure 8. HHS40ZE (3.3V) Derating Curve

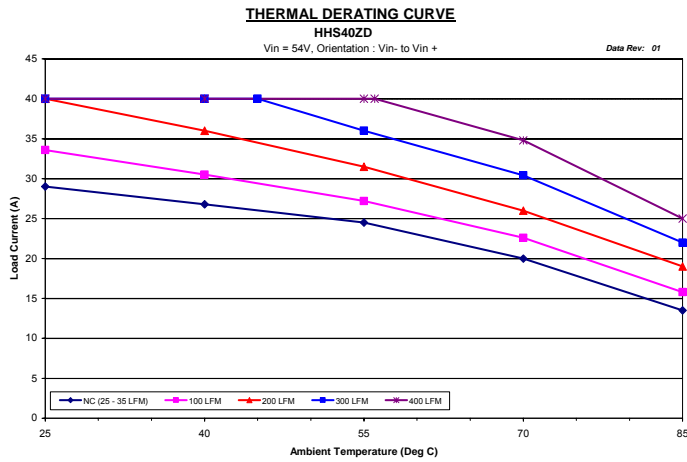

Figure 9. HHS40ZD (2.5V) Derating Curves

Test Setup

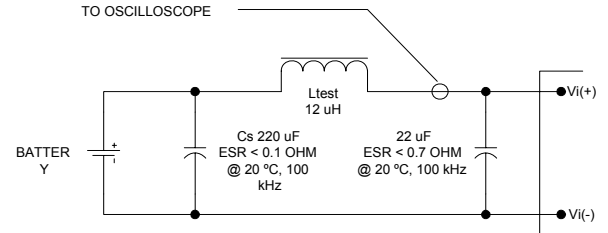

Figure 10. Input Reflected Ripple Current Test Set-up

Note: Measure input reflected-ripple current with a simulated inductance (Ltest) of 12 μ H. Capacitor Cs offsets possible battery impedance. Measure current as shown above.

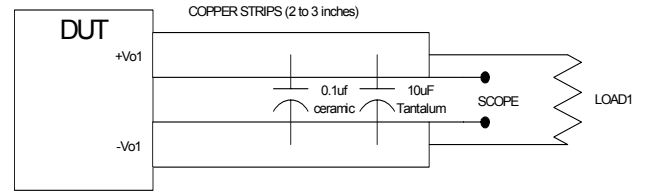

Figure 11. Output Ripple Measurement Test Setup

Note: Use a 0.1 μ F ceramic and 10 μ F tantalum capacitor. Scope measurement should be made using a BNC socket.



Mechanical Drawing

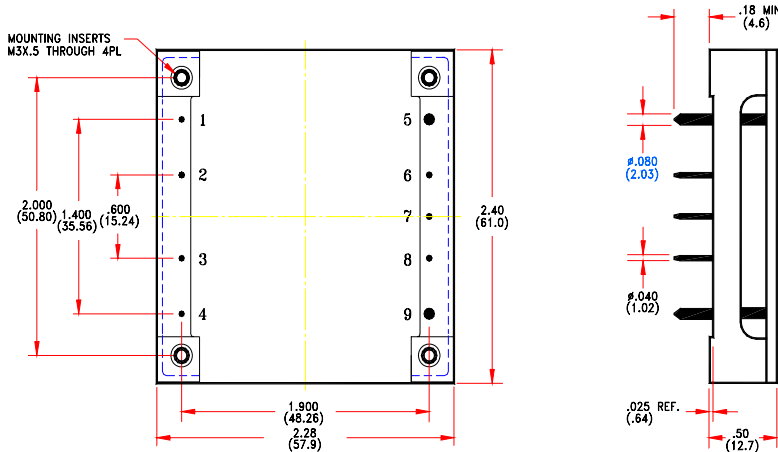

Table 7. Pinout/Functions

Pin	Function
1	-Vin
2	Case
3	On/Off
4	+Vin
5	-Vo
6	-Sense
7	Trim
8	+Sense
9	+Vo

Mechanical Tolerances

Inches	Millimeters
X.XX ±0.020	X.X ±0.5
X.XXX ±0.010	X.XX ±0.25

PIN DIA ±0.002 ±0.05

Ordering:

Table 8. Ordering Information

Options	P/N Suffixes
Trim	Positive (Industry std) - Add "T" suffix
	Negative - no suffix required
Remote ON/OFF	Positive - no suffix required
	Negative - Add "N" suffix
Pin Length	0.18"- Standard - no suffix required
	0.11"- Add "8" suffix ¹
	0.15"- Add "9" suffix ¹

Notes: ¹ Consult factory for available options.

NUCLEAR AND MEDICAL APPLICATIONS - Power-One products are not designed, intended for use in, or authorized for use as critical components in life support systems, equipment used in hazardous environments, or nuclear control systems without the express written consent of the respective divisional president of Power-One, Inc.

TECHNICAL REVISIONS - The appearance of products, including safety agency certifications pictured on labels, may change depending on the date manufactured. Specifications are subject to change without notice.