

MITSUBISHI HIGH VOLTAGE DIODE MODULE

RM1200DB-66S

HIGH POWER SWITCHING USE
INSULATED TYPE

High Voltage Diode Module

RM1200DB-66S



- IF 1200A
- VRRM 3300V
- Insulated Type
- 2-element in a Pack
- Copper Baseplate

APPLICATION

Traction drives, High Reliability Converters / Inverters, DC choppers

OUTLINE DRAWING & CIRCUIT DIAGRAM

Dimensions in mm

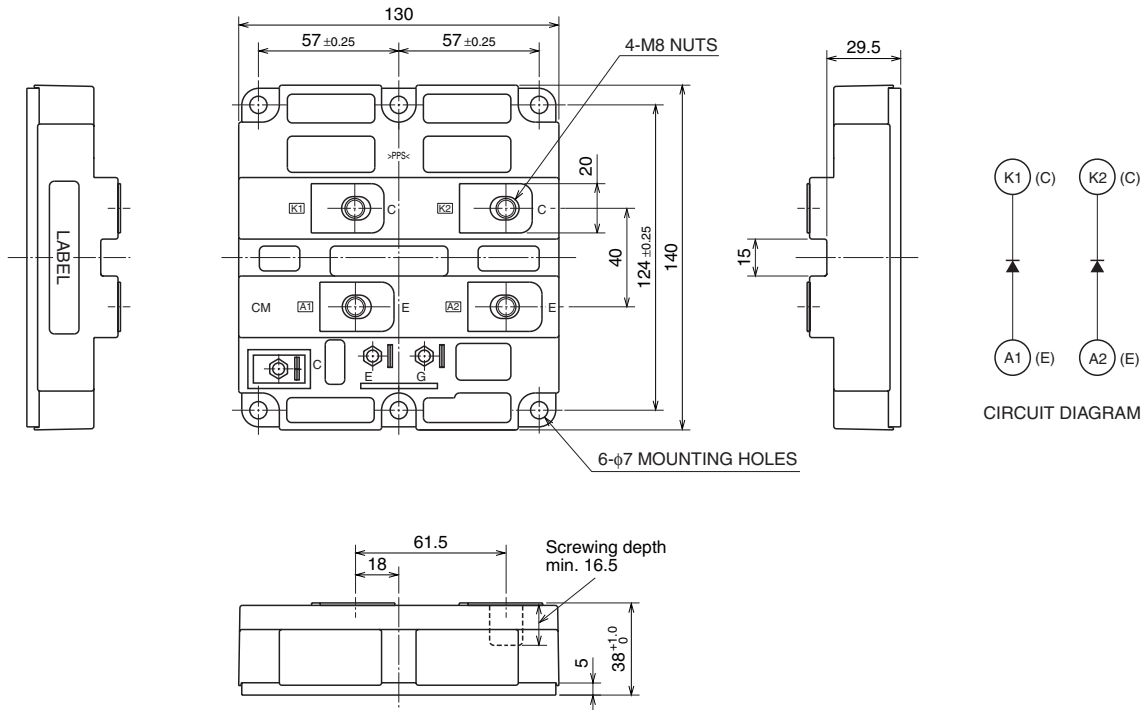

High Voltage Diode Module

May 2009

RM1200DB-66S

**HIGH POWER SWITCHING USE
INSULATED TYPE**

High Voltage Diode Module

MAXIMUM RATINGS

Symbol	Item	Conditions	Ratings	Unit
VRRM	Repetitive peak reverse voltage	T _j = 25 °C	3300	V
VRSM	Non-repetitive peak reverse voltage	T _j = 25 °C	3300	V
VR(DC)	Reverse DC voltage	T _j = 25 °C	2200	V
IF	DC forward current	T _c = 25 °C	1200	A
IFSM	Surge forward current	T _j = 25 °C start, t _w = 8.3 ms Half sign wave	9600	A
i ² t	Current-squared, time integration	T _j = 25 °C start, t _w = 8.3 ms Half sign wave	384	kA ² s
V _{iso}	Isolation voltage	Charged part to the baseplate RMS sinusoidal, 60Hz 1min.	6000	V
T _j	Junction temperature	—	-40 ~ +150	°C
T _{op}	Operating temperature	—	-40 ~ +125	°C
T _{stg}	Storage temperature	—	-40 ~ +125	°C

ELECTRICAL CHARACTERISTICS

Symbol	Item	Conditions	Limits			Unit
			Min	Typ	Max	
IRRM	Repetitive reverse current	V _{RM} = VRRM	T _j = 25 °C	—	5	mA
			T _j = 125 °C	—	30	
VFM	Forward voltage (Note 1)	I _F = 1200 A	T _j = 25 °C	—	2.80	V
			T _j = 125 °C	—	2.70	
t _{rr}	Reverse recovery time	V _R = 1650 V, I _F = 1200 A di/dt = -3700 A/μs L _s =100nH, T _j = 125 °C	—	0.75	—	μs
I _{rr}	Reverse recovery current		—	1600	—	A
Q _{rr}	Reverse recovery charge		—	850	—	μC
E _{rec}	Reverse recovery energy (Note 2)		—	0.75	—	J/P

Note 1. It doesn't include the voltage drop by internal lead resistance.
 2. E_{rec} is the integral of 0.1V_R x 0.1I_{rr} x dt.

RM1200DB-66S

**HIGH POWER SWITCHING USE
INSULATED TYPE**

High Voltage Diode Module

THERMAL CHARACTERISTICS

Symbol	Item	Conditions	Limits			Unit
			Min	Typ	Max	
R _{th(j-c)}	Thermal resistance	Junction to case (per 1/2 module)	—	—	18.0	K/kW
R _{th(c-f)}	Contact thermal resistance	Case to Fin, $\lambda_{grease} = 1W/m\cdot K$ D _(c-f) =100 μ m, (per 1/2 module)	—	16.0	—	K/kW

MECHANICAL CHARACTERISTICS

Symbol	Item	Conditions	Limits			Unit
			Min	Typ	Max	
M _t	Mounting torque	M8: Main terminals screw	7.0	—	13.0	N·m
M _s		M6: Mounting screw	3.0	—	6.0	N·m
m	Mass	—	—	1.5	—	kg
CTI	Comparative tracking index	—	600	—	—	—
D _a	Clearance	—	19.5	—	—	mm
D _s	Creepage distance	—	32	—	—	mm
LP CE	Internal inductance	—	—	35	—	nH
R _{CC'+EE'}	Internal lead resistance	T _c = 25 °C	—	0.25	—	m Ω

PERFORMANCE CURVES

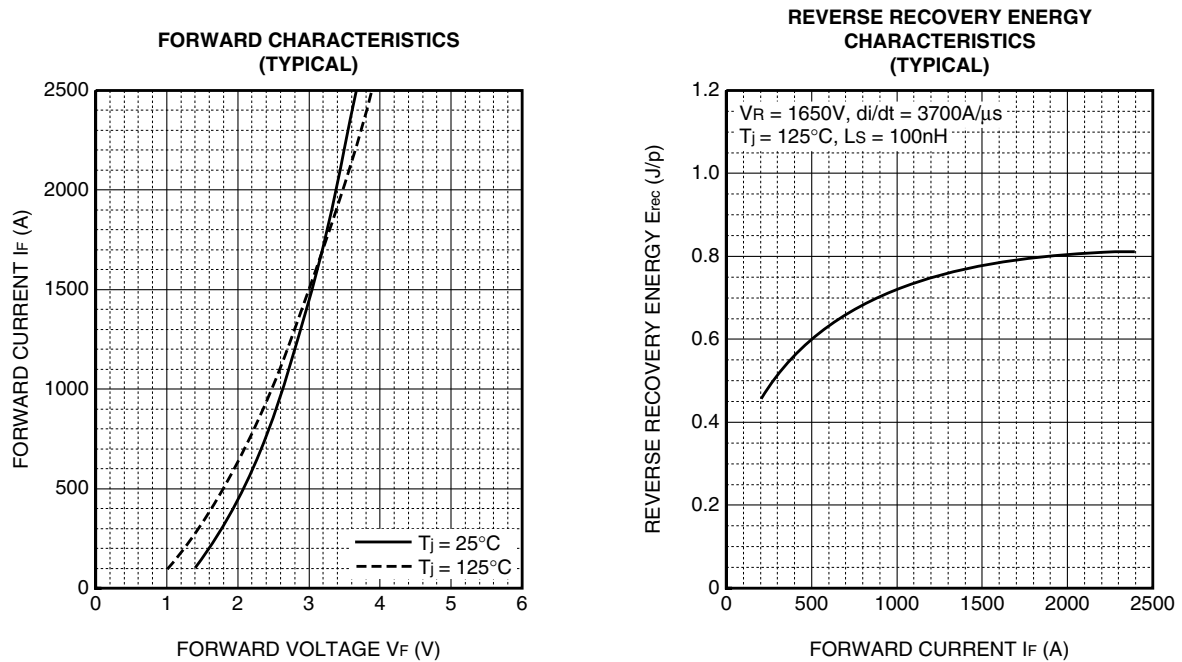

High Voltage Diode Module

RM1200DB-66S

**HIGH POWER SWITCHING USE
INSULATED TYPE**

High Voltage Diode Module

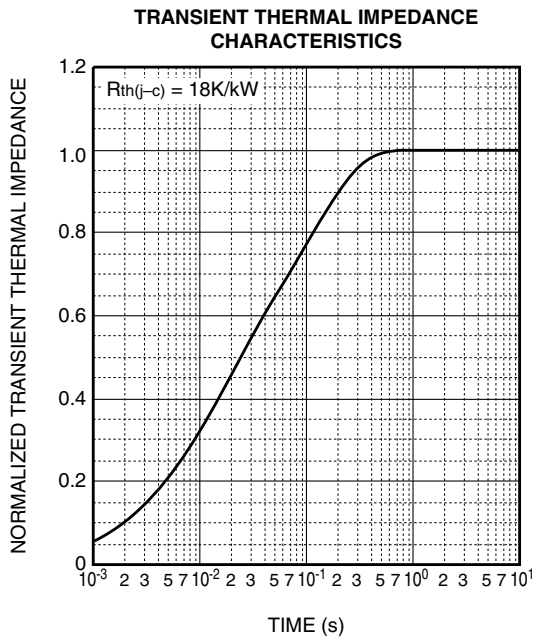
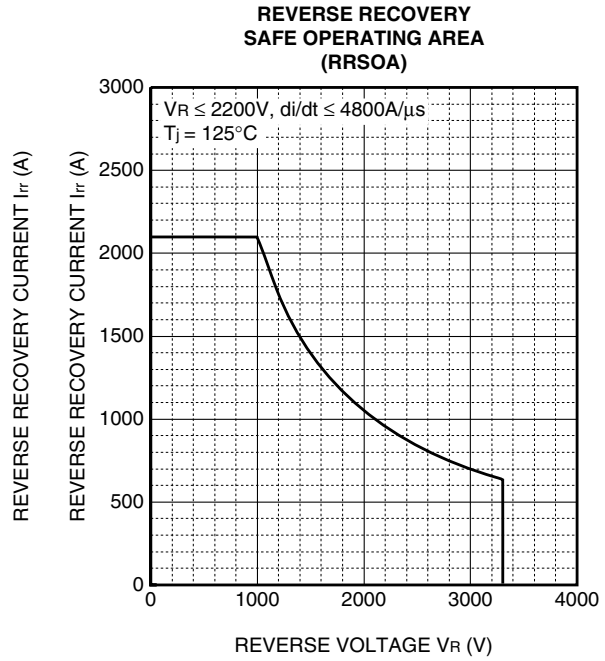
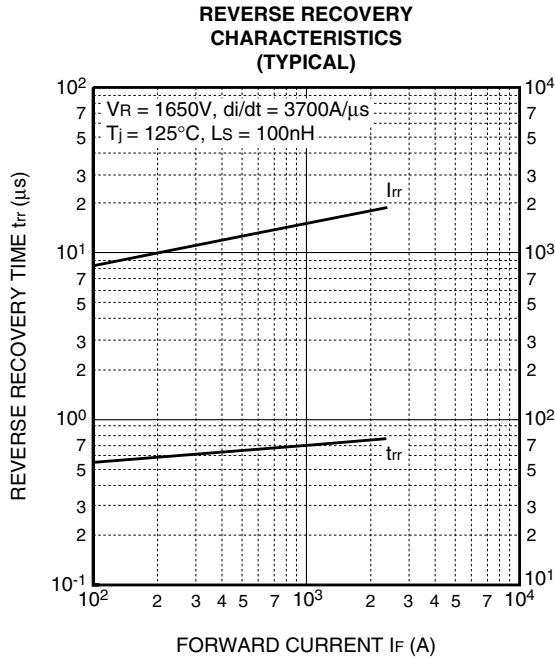

$$Z_{th(j-c)}(t) = \sum_{i=1}^n R_i \left\{ 1 - \exp\left(-\frac{t}{\tau_i}\right) \right\}$$

	1	2	3	4
R_i [K/kW]	0.0059	0.0978	0.6571	0.2392
τ_i [sec]	0.0002	0.0074	0.0732	0.4488

High Voltage Diode Module