

# RM600DG-130S

HIGH POWER SWITCHING USE  
INSULATED TYPE

High Voltage Diode Module

## RM600DG-130S



- IF ..... 600A
- VRRM ..... 6500V
- High Insulated Type
- 2-element in a Pack
- AISiC Baseplate

## APPLICATION

Traction drives, High Reliability Converters / Inverters, DC choppers

## OUTLINE DRAWING & CIRCUIT DIAGRAM

Dimensions in mm

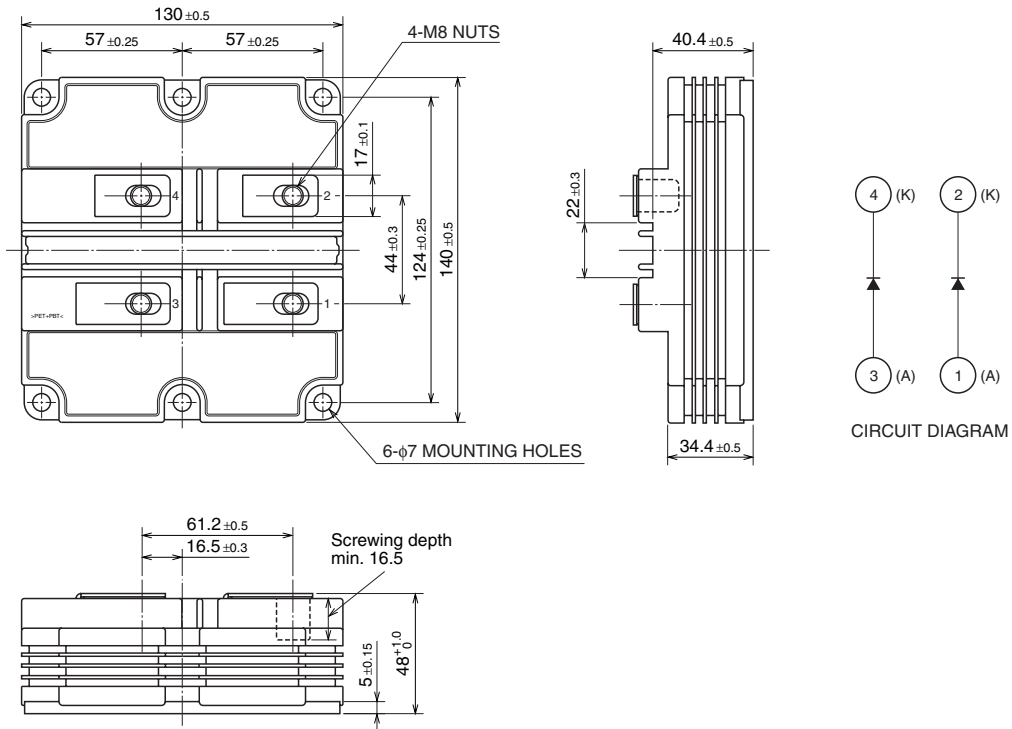

High Voltage Diode Module

May 2009

**RM600DG-130S**

**HIGH POWER SWITCHING USE  
INSULATED TYPE**

High Voltage Diode Module

**MAXIMUM RATINGS**

Symbol	Item	Conditions	Ratings	Unit
V <sub>RRM</sub>	Repetitive peak reverse voltage	T <sub>j</sub> = -40 °C	5800	V
		T <sub>j</sub> = +25 °C	6300	
		T <sub>j</sub> = +125 °C	6500	
V <sub>RSM</sub>	Non-repetitive peak reverse voltage	T <sub>j</sub> = -40 °C	5800	V
		T <sub>j</sub> = +25 °C	6300	
		T <sub>j</sub> = +125 °C	6500	
V <sub>R(DC)</sub>	Reverse DC voltage	T <sub>j</sub> = 25 °C	4500	V
I <sub>F</sub>	DC forward current	T <sub>c</sub> = 25 °C	600	A
I <sub>FSM</sub>	Surge forward current	T <sub>j</sub> = 25 °C start, t <sub>w</sub> = 8.3 ms Half sign wave	4800	A
i <sup>2</sup> t	Current-squared, time integration	T <sub>j</sub> = 25 °C start, t <sub>w</sub> = 8.3 ms Half sign wave	96	kA <sup>2</sup> s
V <sub>iso</sub>	Isolation voltage	Charged part to the baseplate RMS sinusoidal, 60Hz 1min.	10200	V
V <sub>e</sub>	Partial discharge extinction voltage	RMS sinusoidal, 60Hz, QPD ≤ 10PC	5100	V
T <sub>j</sub>	Junction temperature	—	-40 ~ +150	°C
T <sub>op</sub>	Operating temperature	—	-40 ~ +125	°C
T <sub>stg</sub>	Storage temperature	—	-40 ~ +125	°C

**ELECTRICAL CHARACTERISTICS**

Symbol	Item	Conditions	Limits			Unit	
			Min	Typ	Max		
I <sub>RRM</sub>	Repetitive reverse current	V <sub>RM</sub> = V <sub>RRM</sub>	T <sub>j</sub> = 25 °C	—	—	10	mA
			T <sub>j</sub> = 125 °C	—	10	90	
V <sub>FM</sub>	Forward voltage (Note 1)	I <sub>F</sub> = 600 A	T <sub>j</sub> = 25 °C	—	4.00	—	V
			T <sub>j</sub> = 125 °C	—	3.60	—	
t <sub>rr</sub>	Reverse recovery time	V <sub>R</sub> = 3600 V, I <sub>F</sub> = 600 A di/dt = -2000 A/μs L <sub>s</sub> =100nH, T <sub>j</sub> = 125 °C	—	1.0	—	μs	
I <sub>rr</sub>	Reverse recovery current		—	1250	—	A	
Q <sub>rr</sub>	Reverse recovery charge		—	900	—	μC	
E <sub>rec</sub>	Reverse recovery energy (Note 2)		—	2.0	—	J/P	

Note 1. It doesn't include the voltage drop by internal lead resistance.  
2. E<sub>rec</sub> is the integral of 0.1V<sub>R</sub> x 0.1I<sub>rr</sub> x dt.

**RM600DG-130S**

**HIGH POWER SWITCHING USE  
INSULATED TYPE**

High Voltage Diode Module

**THERMAL CHARACTERISTICS**

Symbol	Item	Conditions	Limits			Unit
			Min	Typ	Max	
R <sub>th(j-c)</sub>	Thermal resistance	Junction to case (per 1/2 module)	—	—	22.0	K/kW
R <sub>th(c-f)</sub>	Contact thermal resistance	Case to Fin, λ <sub>grease</sub> = 1W/m·K D(c-f)=100μm, (per 1/2 module)	—	16.0	—	K/kW

**MECHANICAL CHARACTERISTICS**

Symbol	Item	Conditions	Limits			Unit
			Min	Typ	Max	
M <sub>t</sub>	Mounting torque	M8: Main terminals screw	7.0	—	15.0	N·m
M <sub>s</sub>		M6: Mounting screw	3.0	—	6.0	N·m
m	Mass	—	—	1.0	—	kg
CTI	Comparative tracking index	—	600	—	—	—
D <sub>a</sub>	Clearance	—	26	—	—	mm
D <sub>s</sub>	Creepage distance	—	56	—	—	mm
LP CE	Internal inductance	—	—	44	—	nH
RCC'+EE'	Internal lead resistance	T <sub>c</sub> = 25 °C	—	0.27	—	mΩ

**PERFORMANCE CURVES**

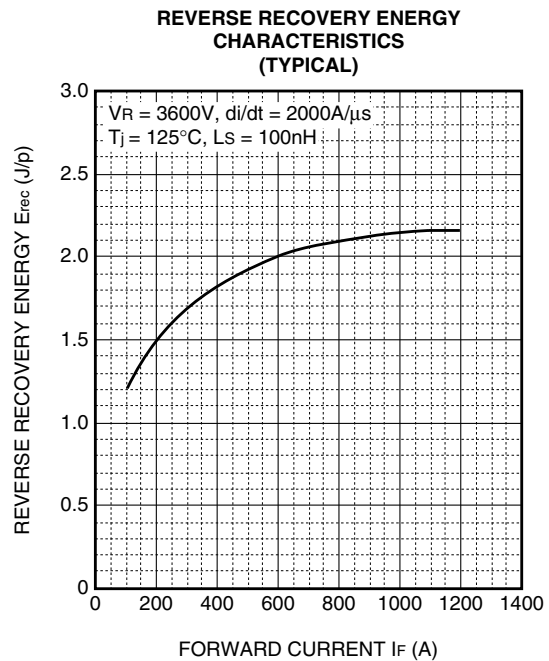
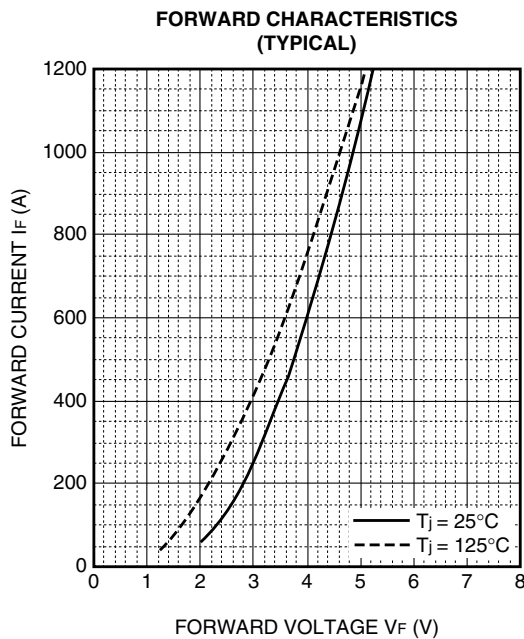

**RM600DG-130S**

**HIGH POWER SWITCHING USE  
INSULATED TYPE**

High Voltage Diode Module

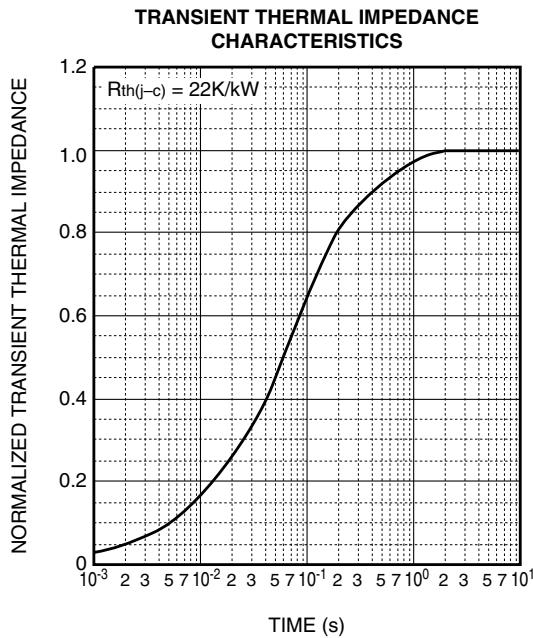
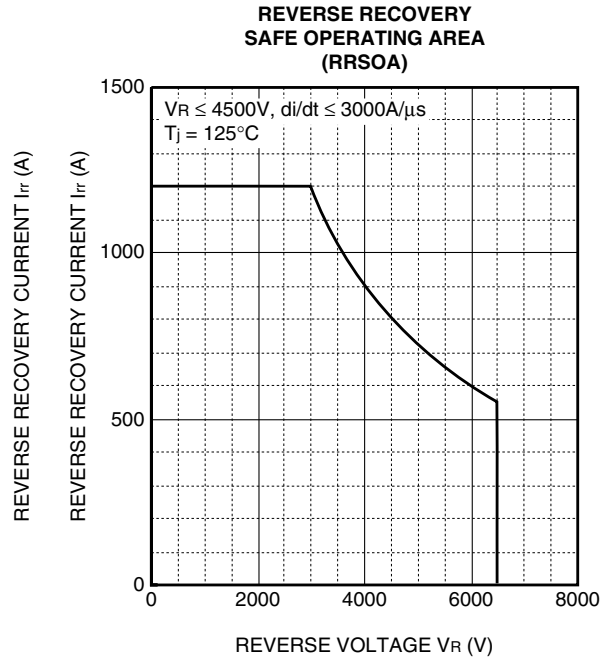
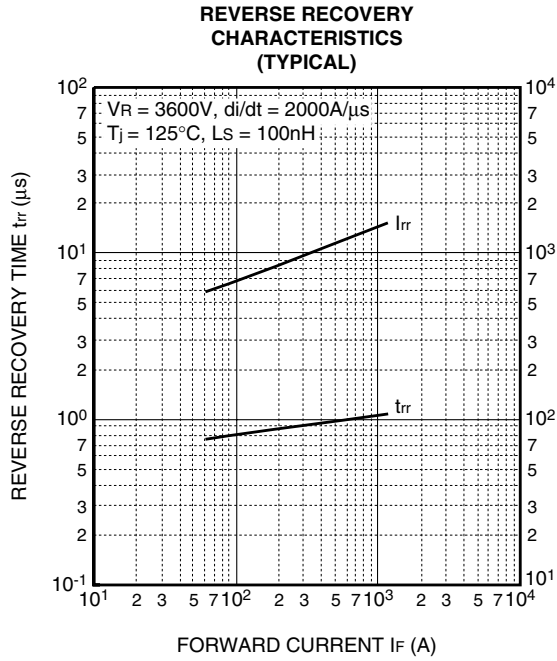

$$Z_{th(j-c)}(t) = \sum_{i=1}^n R_i \left\{ 1 - \exp\left(-\frac{t}{\tau_i}\right) \right\}$$

	1	2	3	4
$R_i$ [K/kW]	0.0059	0.0978	0.6571	0.2392
$\tau_i$ [sec]	0.0002	0.0074	0.0732	0.4488

High Voltage Diode Module