

# MITSUBISHI IGBT MODULES

## CM150RX-12A

HIGH POWER SWITCHING USE

### CM150RX-12A



- Ic ..... 150A
- VCES ..... 600V
- 7pack (3-phase Inverter + Brake)
- Flatbase Type / Insulated Package / Copper (non-plating) base plate
- RoHS Directive compliant

### APPLICATION

General purpose Inverters, Servo Amplifiers

### OUTLINE DRAWING & CIRCUIT DIAGRAM

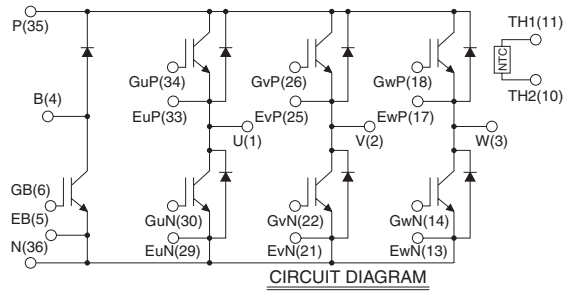
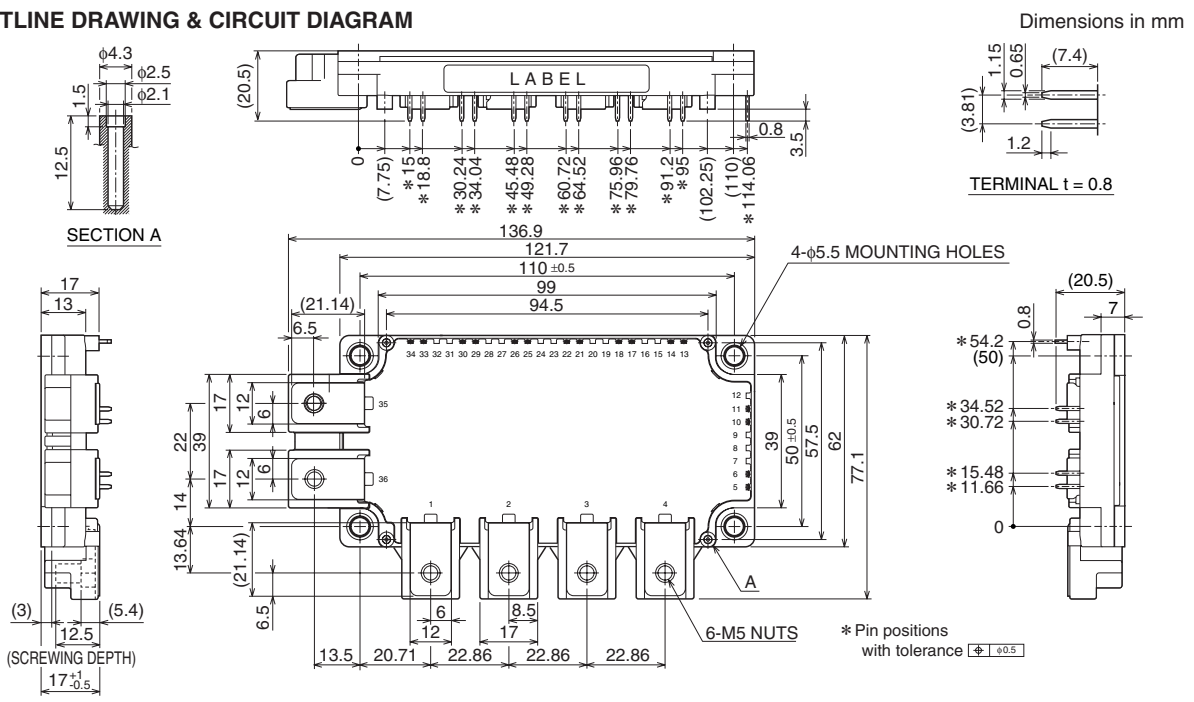

Tolerance otherwise specified

Division of Dimension	Tolerance
0.5 to 3	$\pm 0.2$
over 3 to 6	$\pm 0.3$
over 6 to 30	$\pm 0.5$
over 30 to 120	$\pm 0.8$
over 120 to 400	$\pm 1.2$

# CM150RX-12A

HIGH POWER SWITCHING USE

**ABSOLUTE MAXIMUM RATINGS** (T<sub>j</sub> = 25°C, unless otherwise specified)

**INVERTER PART**

Symbol	Parameter	Conditions	Rating	Unit
V <sub>CES</sub>	Collector-emitter voltage	G-E Short	600	V
V <sub>GES</sub>	Gate-emitter voltage	C-E Short	±20	
I <sub>C</sub>	Collector current	DC, T <sub>c</sub> = 63°C (Note. 1)	150	A
I <sub>CRM</sub>		Pulse (Note. 4)	300	
P <sub>C</sub>	Maximum collector dissipation	T <sub>c</sub> = 25°C (Note. 1, 5)	520	W
I <sub>E</sub> (Note.3)	Emitter current	T <sub>c</sub> = 25°C (Note. 1)	150	A
I <sub>ERM</sub> (Note.3)	(Free wheeling diode forward current)	Pulse (Note. 4)	300	

**BRAKE PART**

Symbol	Parameter	Conditions	Rating	Unit
V <sub>CES</sub>	Collector-emitter voltage	G-E Short	600	V
V <sub>GES</sub>	Gate-emitter voltage	C-E Short	±20	
I <sub>C</sub>	Collector current	DC, T <sub>c</sub> = 70°C (Note. 1)	75	A
I <sub>CRM</sub>		Pulse (Note. 4)	150	
P <sub>C</sub>	Maximum collector dissipation	T <sub>c</sub> = 25°C (Note. 1, 5)	280	W
V <sub>RRM</sub> (Note.3)	Repetitive peak reverse voltage		600	V
I <sub>F</sub> (Note.3)	Forward current	T <sub>c</sub> = 25°C (Note. 1)	75	A
I <sub>FRM</sub> (Note.3)		Pulse (Note. 4)	150	

**MODULE**

Symbol	Parameter	Conditions	Rating	Unit
T <sub>j</sub>	Junction temperature		-40 ~ +150	°C
T <sub>stg</sub>	Storage temperature		-40 ~ +125	
V <sub>iso</sub>	Isolation voltage	Terminals to base plate, f = 60Hz, AC 1 minute	2500	V <sub>rms</sub>
—	Base plate flatness	On the centerline X, Y (Note. 8)	±0 ~ +100	μm
—	Torque strength	Main terminals M5 screw	2.5 ~ 3.5	N·m
—	Torque strength	Mounting M5 screw	2.5 ~ 3.5	
—	Weight	(Typical)	330	g

Note. 8: The base plate flatness measurement points are in the following figure.

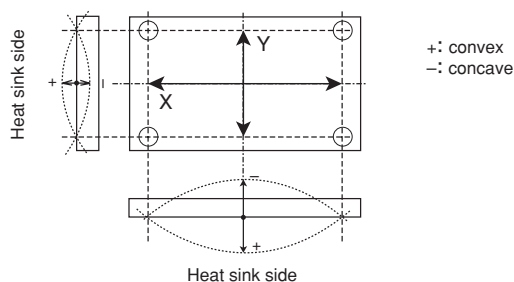

CM150RX-12A

HIGH POWER SWITCHING USE

ELECTRICAL CHARACTERISTICS (T<sub>J</sub> = 25°C, unless otherwise specified)

INVERTER PART

Symbol	Parameter	Conditions	Limits			Unit	
			Min.	Typ.	Max.		
ICES	Collector cutoff current	VCE = VCES, VGE = 0V	—	—	1	mA	
VGE(th)	Gate-emitter threshold voltage	IC = 15mA, VCE = 10V	5	6	7	V	
IGES	Gate leakage current	±VGE = VGES, VCE = 0V	—	—	0.5	μA	
VCE(sat)	Collector-emitter saturation voltage	IC = 150A, VGE = 15V (Note. 6)	T <sub>J</sub> = 25°C	—	1.7	2.1	V
			T <sub>J</sub> = 125°C	—	1.9	—	
			Chip	—	1.6	—	
Cies	Input capacitance	VCE = 10V VGE = 0V (Note. 6)	—	—	18	nF	
Coes	Output capacitance		—	—	2		
Cres	Reverse transfer capacitance		—	—	0.6		
QG	Total gate charge	VCC = 300V, IC = 150A, VGE = 15V	—	300	—	nC	
td(on)	Turn-on delay time	VCC = 300V, IC = 150A	—	—	120	ns	
tr	Turn-on rise time	VGE = ±15V, RG = 6.2Ω	—	—	100		
td(off)	Turn-off delay time	Inductive load (IE = 150A)	—	—	350		
tf	Turn-off fall time		—	—	600		
trr (Note.3)	Reverse recovery time		—	—	200		
Qrr (Note.3)	Reverse recovery charge		—	5	—		μC
VEC(Note.3)	Emitter-collector voltage	IE = 150A, VGE = 0V (Note. 6)	T <sub>J</sub> = 25°C	—	2.0	2.8	V
			T <sub>J</sub> = 125°C	—	1.95	—	
			Chip	—	1.9	—	
Rth(j-c)Q	Thermal resistance (Junction to case) (Note. 1)	per IGBT	—	—	0.24	K/W	
Rth(j-c)R		per free wheeling diode	—	—	0.46		
RGint	Internal gate resistance	Tc = 25°C, per switch	—	0	—	Ω	
RG	External gate resistance		4.1	—	41		

BRAKE PART

Symbol	Parameter	Conditions	Limits			Unit	
			Min.	Typ.	Max.		
ICES	Collector cutoff current	VCE = VCES, VGE = 0V	—	—	1	mA	
VGE(th)	Gate-emitter threshold voltage	IC = 7.5mA, VCE = 10V	5	6	7	V	
IGES	Gate leakage current	±VGE = VGES, VCE = 0V	—	—	0.5	μA	
VCE(sat)	Collector-emitter saturation voltage	IC = 75A, VGE = 15V (Note. 6)	T <sub>J</sub> = 25°C	—	1.7	2.1	V
			T <sub>J</sub> = 125°C	—	1.9	—	
			Chip	—	1.6	—	
Cies	Input capacitance	VCE = 10V VGE = 0V (Note. 6)	—	—	9.3	nF	
Coes	Output capacitance		—	—	1.0		
Cres	Reverse transfer capacitance		—	—	0.3		
QG	Total gate charge	VCC = 300V, IC = 75A, VGE = 15V	—	200	—	nC	
IRRM(Note.3)	Repetitive peak reverse current	VR = VRRM	—	—	1	mA	
VFM(Note.3)	Forward voltage drop	IF = 75A (Note. 6)	T <sub>J</sub> = 25°C	—	2.0	2.8	V
			T <sub>J</sub> = 125°C	—	1.95	—	
			Chip	—	1.9	—	
Rth(j-c)Q	Thermal resistance (Junction to case) (Note. 1)	per IGBT	—	—	0.44	K/W	
Rth(j-c)R		per Clamp diode	—	—	0.85		
RGint	Internal gate resistance	Tc = 25°C	—	0	—	Ω	
RG	External gate resistance		8.0	—	83		

# CM150RX-12A

## HIGH POWER SWITCHING USE

### NTC THERMISTOR PART

Symbol	Parameter	Conditions	Limits			Unit
			Min.	Typ.	Max.	
R	Zero power resistance	Tc = 25°C	4.85	5.00	5.15	kΩ
ΔR/R	Deviation of resistance	Tc = 100°C, R100 = 493Ω	-7.3	—	+7.8	%
B(25/50)	B constant	Approximate by equation (Note. 7)	—	3375	—	K
P25	Power dissipation	Tc = 25°C	—	—	10	mW

### MODULE

Symbol	Parameter	Conditions	Limits			Unit
			Min.	Typ.	Max.	
Rth(c-f)	Contact thermal resistance (Case to fin) (Note. 1)	Thermal grease applied per 1 module (Note. 2)	—	0.015	—	K/W

Note. 1: Case temperature (Tc), heat sink temperature (Tf) measured point is just under the chips. (Refer to the figure of the chip location.)

2: Typical value is measured by using thermally conductive grease of λ = 0.9W/(m·K).

3: IE, IERM, VEC, tr and Qrr represent ratings and characteristics of the anti-parallel, emitter-collector free wheeling diode (FWDi).

IF, IFRM, VF, VRRM and IRRM represent ratings and characteristics of the Clamp diode of Brake part.

4: Pulse width and repetition rate should be such that the device junction temperature (Tj) dose not exceed Tjmax rating.

5: Junction temperature (Tj) should not increase beyond 150°C.

6: Pulse width and repetition rate should be such as to cause negligible temperature rise.

(Refer to the figure of the test circuit for VCE(sat) and VEC)

$$7: B(25/50) = \ln\left(\frac{R_{25}}{R_{50}}\right) / \left(\frac{1}{T_{25}} - \frac{1}{T_{50}}\right)$$

R25: resistance at absolute temperature T25 [K]; T25 = 25 [°C]+273.15 = 298.15 [K]

R50: resistance at absolute temperature T50 [K]; T50 = 50 [°C]+273.15 = 323.15 [K]

### Chip Location (Top view)

Dimensions in mm (tolerance: ±1mm)

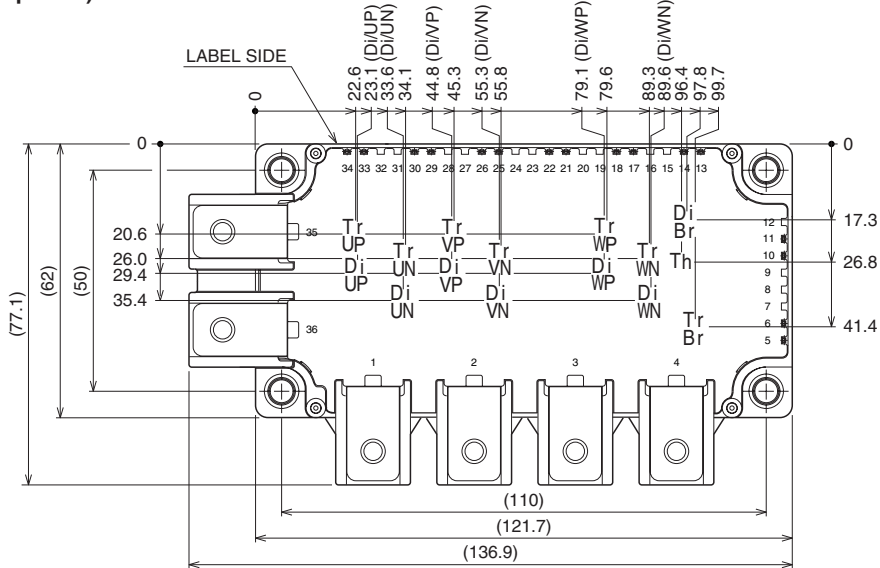

Each mark points the center position of each chip. Tr\*\*: IGBT, Di\*\*: FWDi (DiBr: Clamp diode), Th: NTC thermistor

# CM150RX-12A

HIGH POWER SWITCHING USE

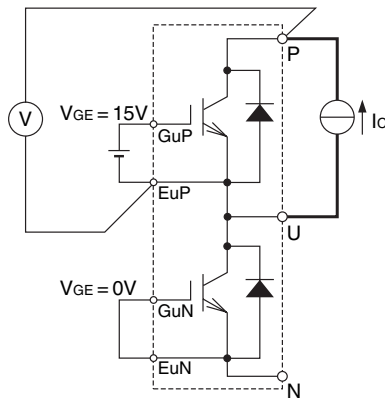

P side Inverter part Tr  
(example of U arm)  
 $V_{GE} = 0V(G_{vP-EvP}, G_{wP-EwP}, G_{vN-EvN}, G_{wN-EwN}, GB-EB)$

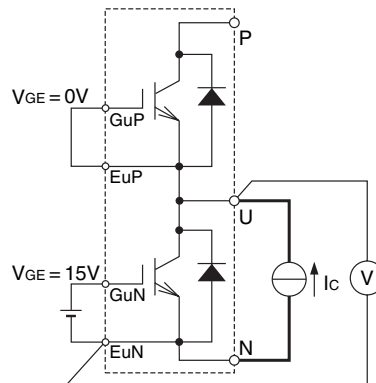

N side Inverter part Tr  
(example of U arm)  
 $V_{GE} = 0V(G_{vP-EvP}, G_{wP-EwP}, G_{vN-EvN}, G_{wN-EwN}, GB-EB)$

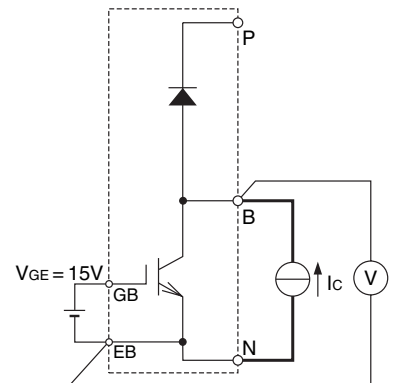

Br Tr  
 $V_{GE} = 0V(G_{uP-EuP}, G_{vP-EvP}, G_{wP-EwP}, G_{uN-EuN}, G_{vN-EvN}, G_{wN-EwN})$

**VCE(sat) test circuit**

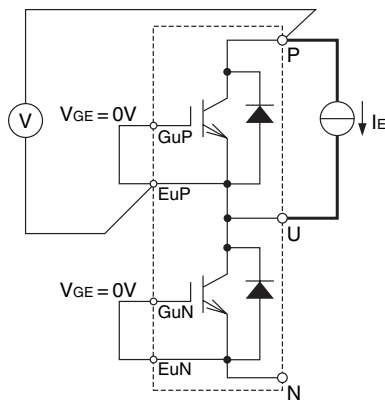

P side Inverter part Di  
(example of U arm)  
 $V_{GE} = 0V(G_{vP-EvP}, G_{wP-EwP}, G_{vN-EvN}, G_{wN-EwN}, GB-EB)$

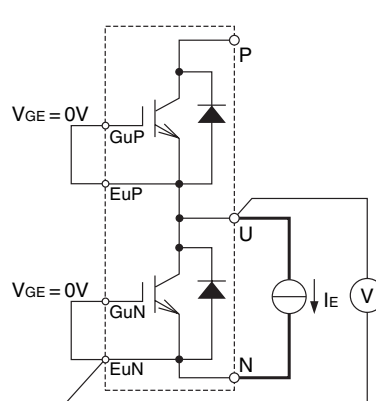

N side Inverter part Di  
(example of U arm)  
 $V_{GE} = 0V(G_{vP-EvP}, G_{wP-EwP}, G_{vN-EvN}, G_{wN-EwN}, GB-EB)$

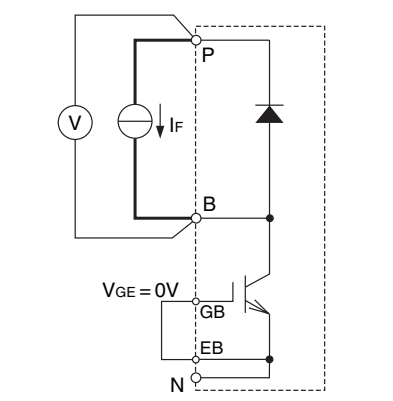

Br Di  
 $V_{GE} = 0V(G_{uP-EuP}, G_{vP-EvP}, G_{wP-EwP}, G_{uN-EuN}, G_{vN-EvN}, G_{wN-EwN})$

**VEC/VFM test circuit**

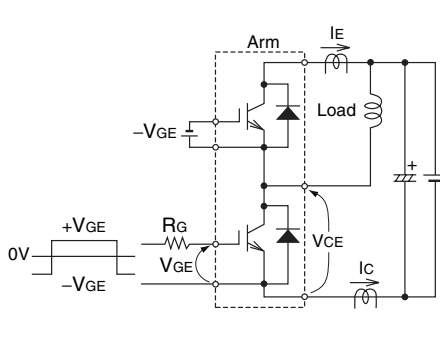

Switching time test circuit and waveforms

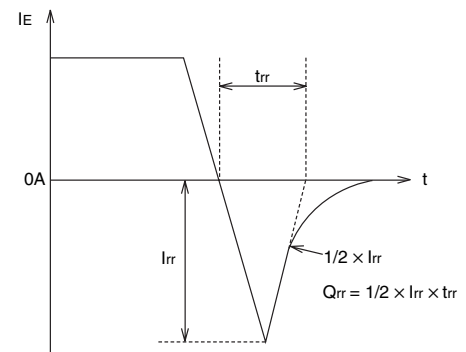
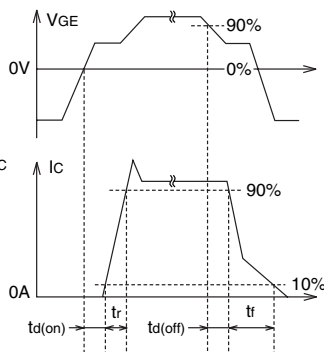

$t_{rr}, Q_{rr}$  test waveform

# CM150RX-12A

HIGH POWER SWITCHING USE

## PERFORMANCE CURVES

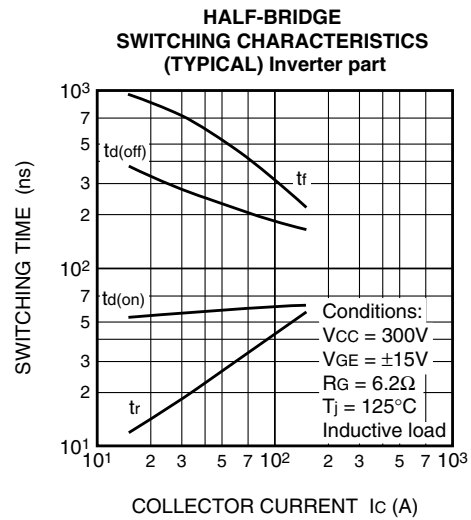
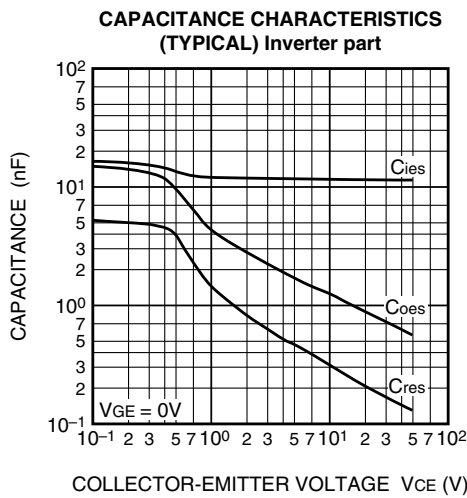
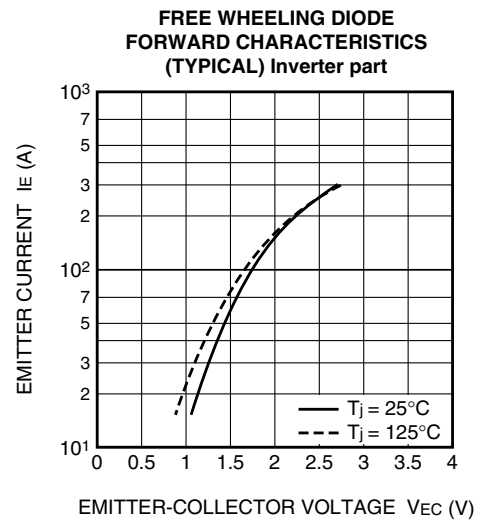
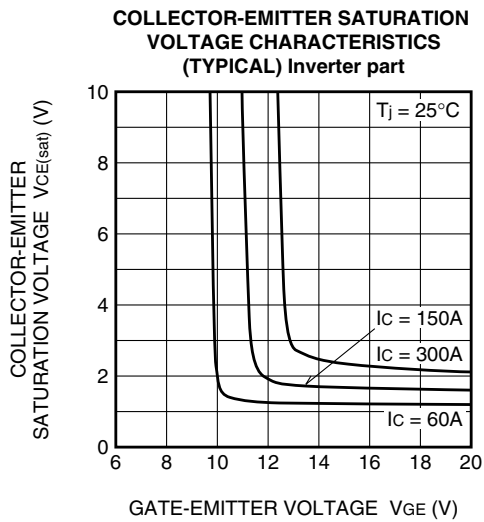
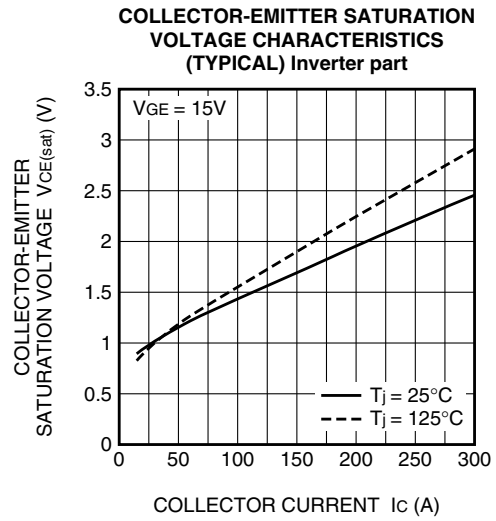
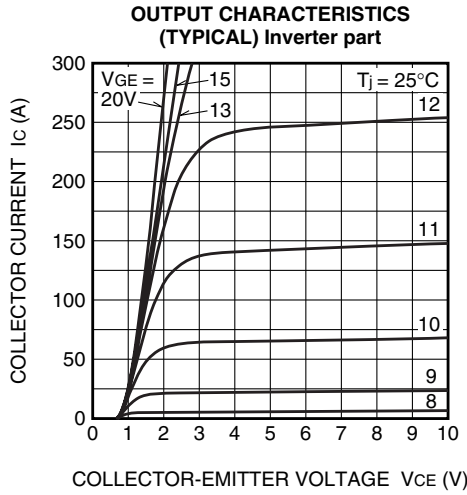

**HALF-BRIDGE SWITCHING CHARACTERISTICS (TYPICAL) Inverter part**

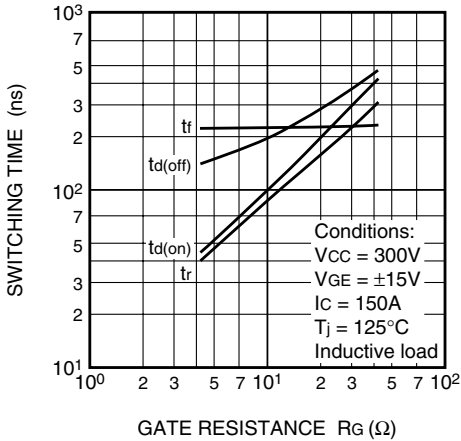

**HALF-BRIDGE SWITCHING CHARACTERISTICS (TYPICAL) Inverter part**

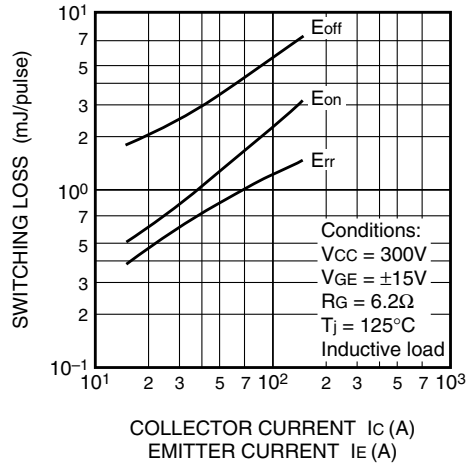

**HALF-BRIDGE SWITCHING CHARACTERISTICS (TYPICAL) Inverter part**

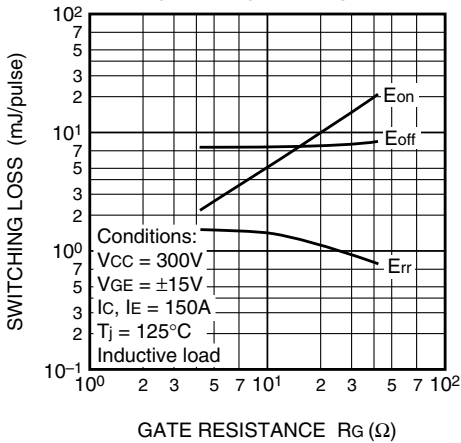

**REVERSE RECOVERY CHARACTERISTICS OF FREE WHEELING DIODE (TYPICAL) Inverter part**

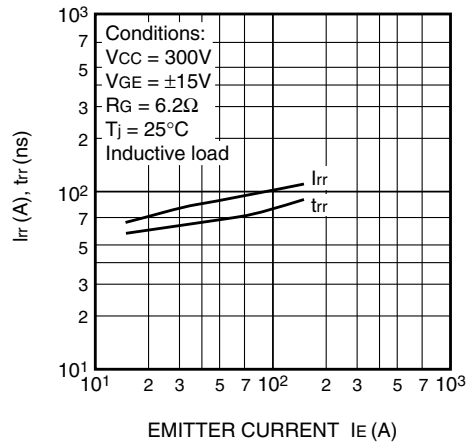

**GATE CHARGE CHARACTERISTICS (TYPICAL) Inverter part**

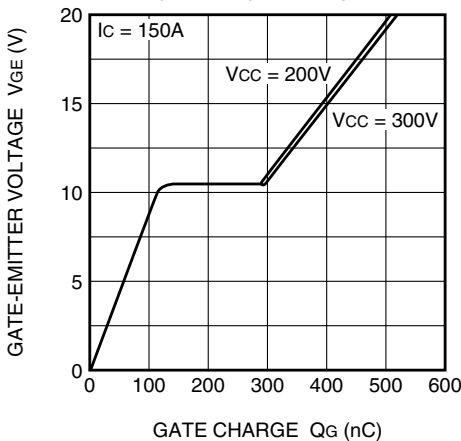

**TRANSIENT THERMAL IMPEDANCE CHARACTERISTICS**

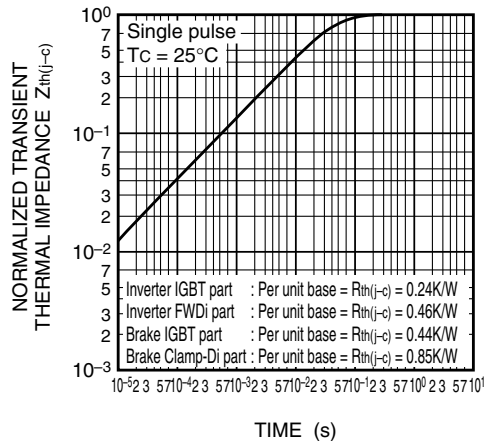

CM150RX-12A

HIGH POWER SWITCHING USE

COLLECTOR-EMITTER SATURATION VOLTAGE CHARACTERISTICS (TYPICAL) Brake part

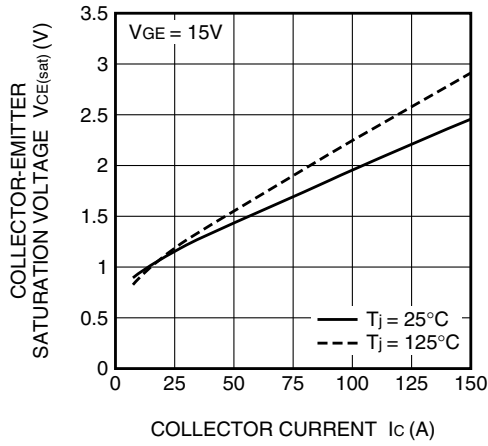

CLAMP DIODE FORWARD CHARACTERISTICS (TYPICAL) Brake part

