

MITSUBISHI IGBT MODULES  
**CM600DU-5F**

HIGH POWER SWITCHING USE

**CM600DU-5F**



- Ic ..... 600A
- VCES ..... 250V
- Insulated Type
- 2-elements in a pack

**APPLICATION**

AC motor control of forklift (battery power source)

**OUTLINE DRAWING & CIRCUIT DIAGRAM**

Dimensions in mm

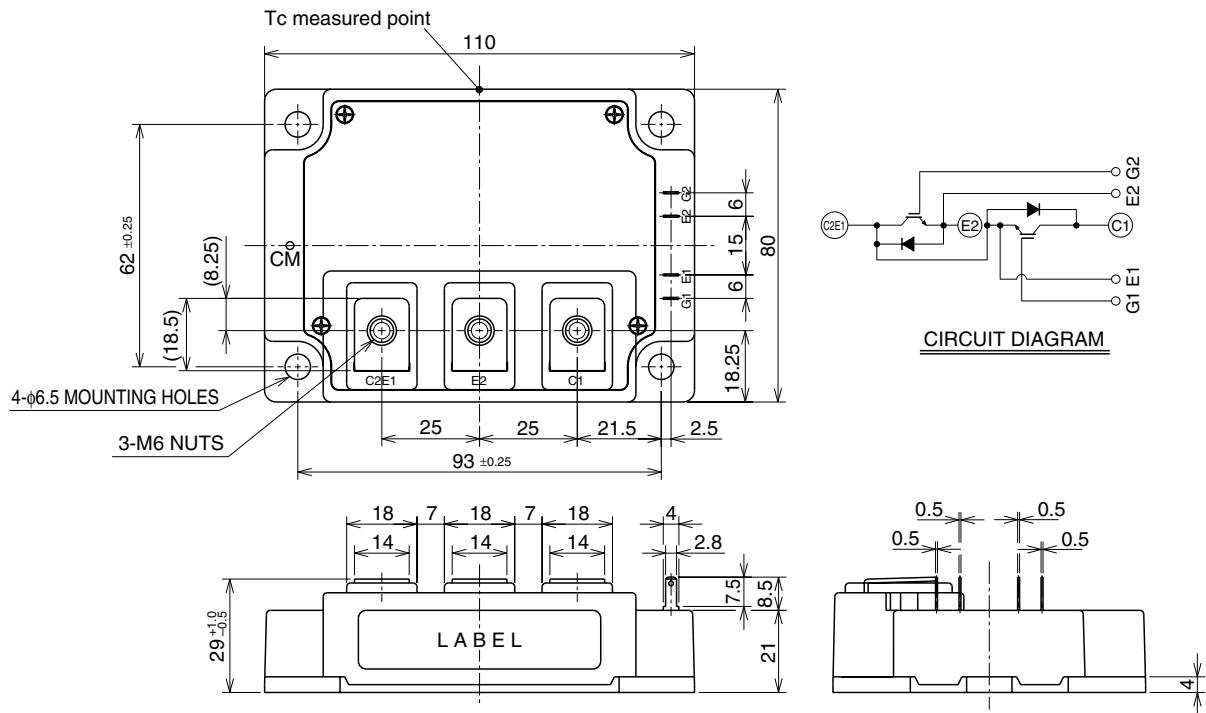

**CM600DU-5F**

**HIGH POWER SWITCHING USE**

**MAXIMUM RATINGS (Tj = 25°C, unless otherwise specified)**

Symbol	Parameter	Conditions	Ratings	Unit
VCES	Collector-emitter voltage	G-E Short	250	V
VGES	Gate-emitter voltage	C-E Short	±20	V
Ic	Collector current	Tc = 25°C	600	A
Ic(rms)			350	A(rms)
ICM		Pulse (Note 2)	1200	A
IE (Note 1)	Emitter current	Tc = 25°C	600	A
IE(rms) (Note 1)			350	A(rms)
IEM (Note 1)		Pulse (Note 2)	1200	A
PC (Note 3)	Maximum collector dissipation	Tc = 25°C	1100	W
Tj	Junction temperature		-40 ~ +150	°C
Tstg	Storage temperature		-40 ~ +125	°C
Viso	Isolation voltage	Terminals to base plate, f = 60Hz, AC 1 minute	2500	Vrms
—	Torque strength	Main terminals M6 screw	3.5 ~ 4.5	N • m
		Mounting M6 screw	3.5 ~ 4.5	N • m
—	Weight	Typical value	580	g

**ELECTRICAL CHARACTERISTICS (Tj = 25°C, unless otherwise specified)**

Symbol	Parameter	Test conditions	Limits			Unit	
			Min.	Typ.	Max.		
ICES	Collector cutoff current	VCE = VCES, VGE = 0V	—	—	1	mA	
VGE(th)	Gate-emitter threshold voltage	Ic = 60mA, VCE = 10V	3.0	4.0	5.0	V	
IGES	Gate leakage current	±VGE = VGES, VCE = 0V	—	—	0.5	µA	
VCE(sat)	Collector-emitter saturation voltage	Ic = 600A, VGE = 10V	Tj = 25°C	—	1.2	1.7	V
			Tj = 125°C	—	1.1	—	
Cies	Input capacitance	VCE = 10V VGE = 0V	—	—	170	nF	
Coes	Output capacitance		—	—	11		
Cres	Reverse transfer capacitance		—	—	5.7		
QG	Total gate charge	VCC = 100V, Ic = 600A, VGE = 10V	—	2200	—	nC	
td(on)	Turn-on delay time	VCC = 100V, Ic = 600A VGE = ±10V RG = 4.2Ω, Inductive load IE = 600A	—	—	850	ns	
tr	Turn-on rise time		—	—	600		
td(off)	Turn-off delay time		—	—	1100		
tf	Turn-off fall time		—	—	500		
trr (Note 1)	Reverse recovery time		—	—	300		
Qrr (Note 1)	Reverse recovery charge		—	20.0	—		µC
VEC(Note 1)	Emitter-collector voltage	IE = 600A, VGE = 0V	—	—	2	V	
Rth(j-c)Q	Thermal resistance*1	IGBT part (1/2 module)	—	—	0.11	K/W	
Rth(j-c)R		FWDi part (1/2 module)	—	—	0.20		
Rth(c-f)	Contact thermal resistance	Case to heat sink, Thermal compound applied*2 (1/2 module)	—	0.02	—		
Rth(j-c)Q	Thermal resistance*3	Case temperature measured point is just under the chips	—	—	0.05		

Note 1. IE, VEC, trr, Qrr & die/dt represent characteristics of the anti-parallel, emitter-collector free-wheel diode (FWDi).

2. Pulse width and repetition rate should be such that the device junction temperature (Tj) does not exceed Tjmax rating.

3. Junction temperature (Tj) should not increase beyond 150°C.

4. Pulse width and repetition rate should be such as to cause negligible temperature rise.

\*1 : Case temperature (Tc) measured point is indicated in OUTLINE DRAWING.

\*2 : Typical value is measured by using thermally conductive grease of λ = 0.9[W/(m • K)].

\*3 : If you use this value, Rth(f-a) should be measured just under the chips.

PERFORMANCE CURVES

OUTPUT CHARACTERISTICS (TYPICAL)

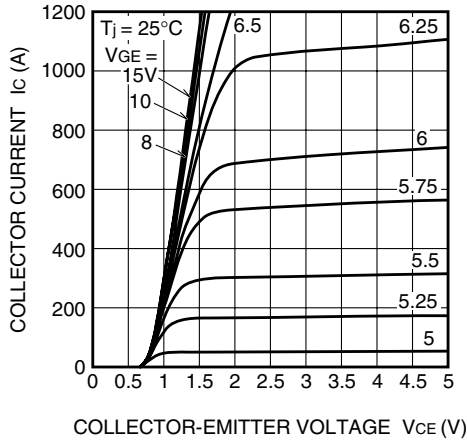

TRANSFER CHARACTERISTICS (TYPICAL)

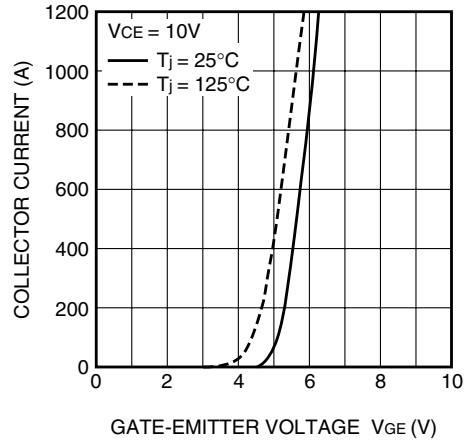

COLLECTOR-EMITTER SATURATION VOLTAGE CHARACTERISTICS (TYPICAL)

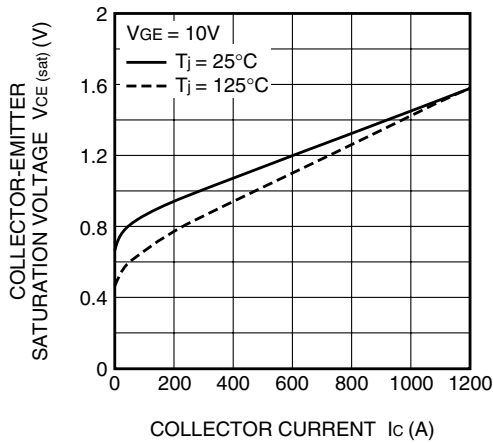

COLLECTOR-EMITTER SATURATION VOLTAGE CHARACTERISTICS (TYPICAL)

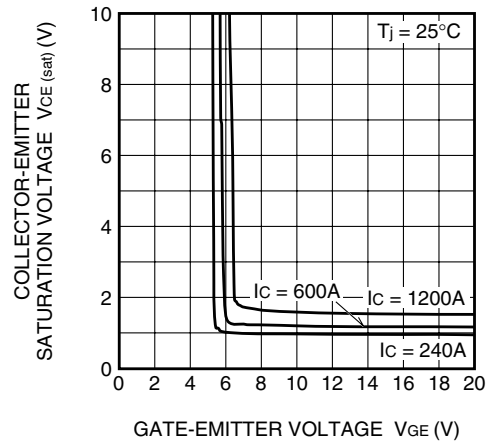

FREE-WHEEL DIODE FORWARD CHARACTERISTICS (TYPICAL)

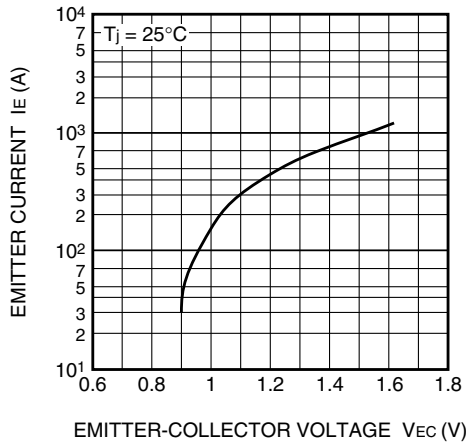

CAPACITANCE-VCE CHARACTERISTICS (TYPICAL)

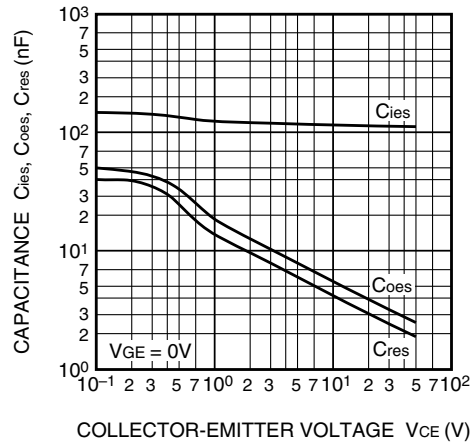

HALF-BRIDGE SWITCHING CHARACTERISTICS (TYPICAL)

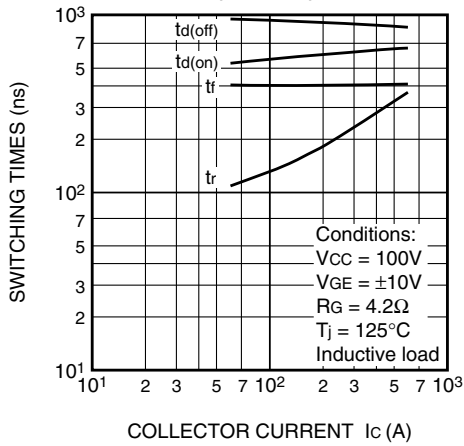

REVERSE RECOVERY CHARACTERISTICS OF FREE-WHEEL DIODE (TYPICAL)

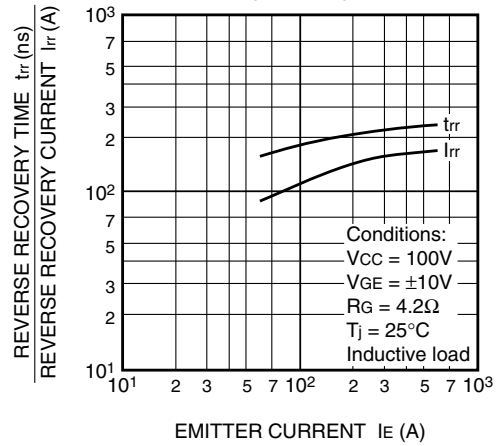

TRANSIENT THERMAL IMPEDANCE CHARACTERISTICS (IGBT part & FWDi part)

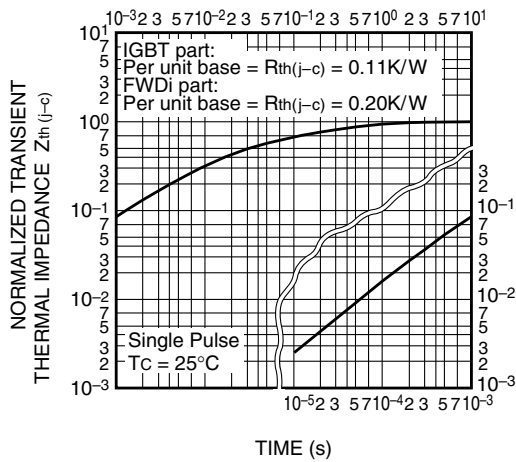

GATE CHARGE CHARACTERISTICS (TYPICAL)

