

CM75RX-24A

HIGH POWER SWITCHING USE

CM75RX-24A



- Ic 75A
- VCES 1200V
- 7pack (3-phase Inverter + Brake)
- Flatbase Type / Insulated Package / Copper (non-plating) base plate
- RoHS Directive compliant

APPLICATION

General purpose Inverters, Servo Amplifiers

OUTLINE DRAWING & CIRCUIT DIAGRAM

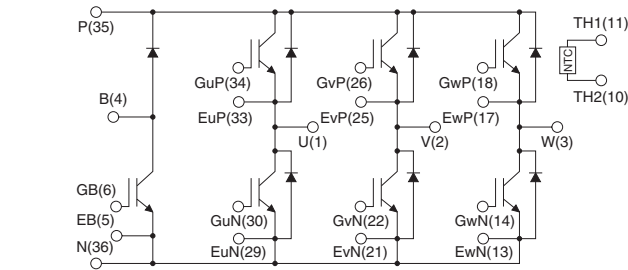
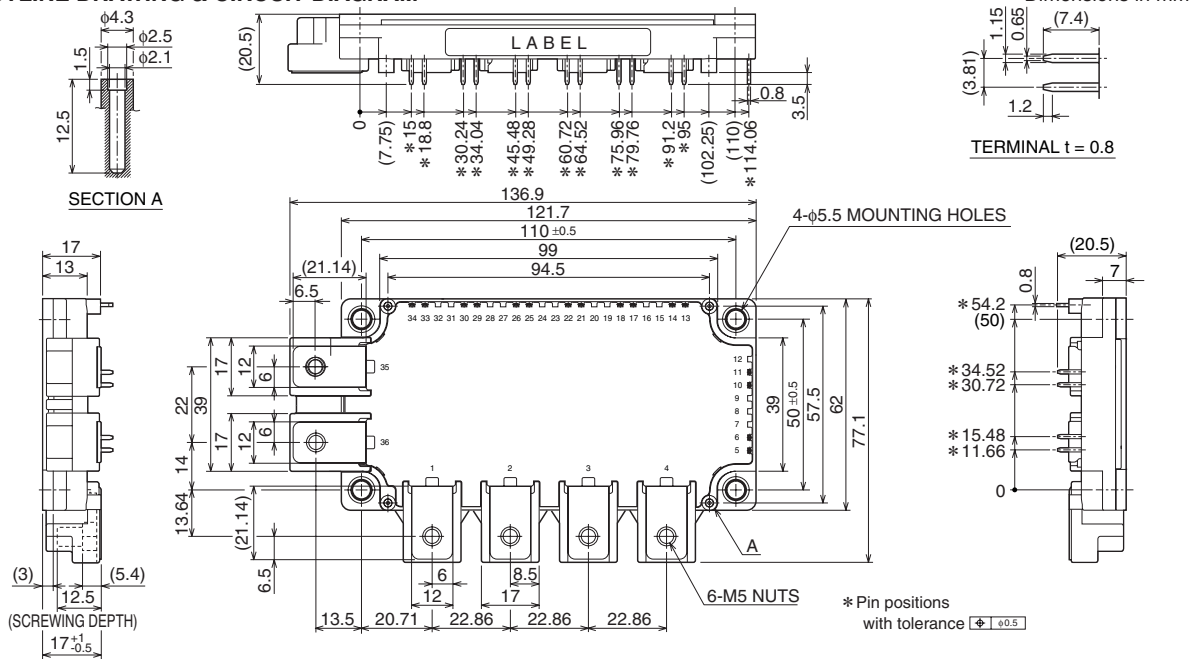

CIRCUIT DIAGRAM

Tolerance otherwise specified

Division of Dimension	Tolerance
0.5 to 3	±0.2
over 3 to 6	±0.3
over 6 to 30	±0.5
over 30 to 120	±0.8
over 120 to 400	±1.2

CM75RX-24A

HIGH POWER SWITCHING USE

ABSOLUTE MAXIMUM RATINGS (T_j = 25°C, unless otherwise specified)

INVERTER PART

Symbol	Parameter	Conditions	Rating	Unit
V _{CES}	Collector-emitter voltage	G-E Short	1200	V
V _{GES}	Gate-emitter voltage	C-E Short	±20	
I _C	Collector current	DC, T _c = 93°C (Note. 1)	75	A
I _{CRM}		Pulse (Note. 4)	150	
P _C	Maximum collector dissipation	T _c = 25°C (Note. 1, 5)	500	W
I _E (Note.3)	Emitter current	T _c = 25°C (Note. 1)	75	A
I _{ERM} (Note.3)	(Free wheeling diode forward current)	Pulse (Note. 4)	150	

BRAKE PART

Symbol	Parameter	Conditions	Rating	Unit
V _{CES}	Collector-emitter voltage	G-E Short	1200	V
V _{GES}	Gate-emitter voltage	C-E Short	±20	
I _C	Collector current	DC, T _c = 97°C (Note. 1)	50	A
I _{CRM}		Pulse (Note. 4)	100	
P _C	Maximum collector dissipation	T _c = 25°C (Note. 1, 5)	355	W
V _{RRM} (Note.3)	Repetitive peak reverse voltage		1200	V
I _F (Note.3)	Forward current	T _c = 25°C (Note. 1)	50	A
I _{FRM} (Note.3)		Pulse (Note. 4)	100	

MODULE

Symbol	Parameter	Conditions	Rating	Unit
T _j	Junction temperature		-40 ~ +150	°C
T _{stg}	Storage temperature		-40 ~ +125	
V _{iso}	Isolation voltage	Terminals to base plate, f = 60Hz, AC 1 minute	2500	V _{rms}
—	Base plate flatness	On the centerline X, Y (Note. 8)	±0 ~ +100	μm
—	Torque strength	Main terminals M5 screw	2.5 ~ 3.5	N·m
—	Torque strength	Mounting M5 screw	2.5 ~ 3.5	
—	Weight	(Typical)	330	g

Note. 8: The base plate flatness measurement points are in the following figure.

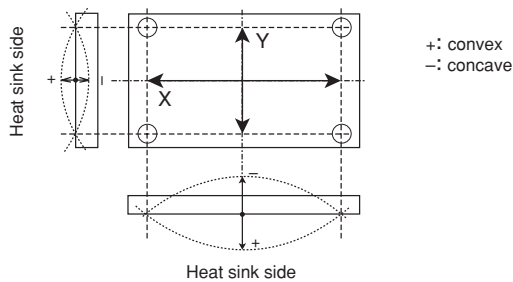

CM75RX-24A

HIGH POWER SWITCHING USE

ELECTRICAL CHARACTERISTICS (T_J = 25°C, unless otherwise specified)

INVERTER PART

Symbol	Parameter	Conditions	Limits			Unit	
			Min.	Typ.	Max.		
ICES	Collector cutoff current	VCE = VCES, VGE = 0V	—	—	1	mA	
VGE(th)	Gate-emitter threshold voltage	IC = 7.5mA, VCE = 10V	6	7	8	V	
IGES	Gate leakage current	±VGE = VGES, VCE = 0V	—	—	0.5	μA	
VCE(sat)	Collector-emitter saturation voltage	IC = 75A, VGE = 15V (Note. 6)	T _J = 25°C	—	2.0	2.6	V
			T _J = 125°C	—	2.2	—	
			Chip	—	1.9	—	
Cies	Input capacitance	VCE = 10V VGE = 0V (Note. 6)	—	—	11.5	nF	
Coes	Output capacitance		—	—	1.0		
Cres	Reverse transfer capacitance		—	—	0.23		
QG	Total gate charge	VCC = 600V, IC = 75A, VGE = 15V	—	380	—	nC	
td(on)	Turn-on delay time	VCC = 600V, IC = 75A	—	—	100	ns	
tr	Turn-on rise time	VGE = ±15V, RG = 4.3Ω	—	—	50		
td(off)	Turn-off delay time	Inductive load	—	—	300		
tf	Turn-off fall time		—	—	600		
trr (Note.3)	Reverse recovery time		(IE = 75A)	—	—		150
Qrr (Note.3)	Reverse recovery charge		—	3	—	μC	
VEC(Note.3)	Emitter-collector voltage	IE = 75A, VGE = 0V (Note. 6)	T _J = 25°C	—	2.6	3.4	V
			T _J = 125°C	—	2.16	—	
			Chip	—	2.5	—	
Rth(j-c)Q	Thermal resistance (Junction to case) (Note. 1)	per IGBT	—	—	0.25	K/W	
Rth(j-c)R		per free wheeling diode	—	—	0.40		
RGint	Internal gate resistance	Tc = 25°C, per switch	—	0	—	Ω	
RG	External gate resistance		4.1	—	41		

BRAKE PART

Symbol	Parameter	Conditions	Limits			Unit	
			Min.	Typ.	Max.		
ICES	Collector cutoff current	VCE = VCES, VGE = 0V	—	—	1	mA	
VGE(th)	Gate-emitter threshold voltage	IC = 5mA, VCE = 10V	6	7	8	V	
IGES	Gate leakage current	±VGE = VGES, VCE = 0V	—	—	0.5	μA	
VCE(sat)	Collector-emitter saturation voltage	IC = 50A, VGE = 15V (Note. 6)	T _J = 25°C	—	2.0	2.6	V
			T _J = 125°C	—	2.2	—	
			Chip	—	1.9	—	
Cies	Input capacitance	VCE = 10V VGE = 0V (Note. 6)	—	—	8.5	nF	
Coes	Output capacitance		—	—	0.75		
Cres	Reverse transfer capacitance		—	—	0.17		
QG	Total gate charge	VCC = 600V, IC = 50A, VGE = 15V	—	250	—	nC	
IRRM(Note.3)	Repetitive peak reverse current	VR = VRRM	—	—	1	mA	
VFM(Note.3)	Forward voltage drop	IF = 50A (Note. 6)	T _J = 25°C	—	2.6	3.4	V
			T _J = 125°C	—	2.16	—	
			Chip	—	2.5	—	
Rth(j-c)Q	Thermal resistance (Junction to case) (Note. 1)	per IGBT	—	—	0.35	K/W	
Rth(j-c)R		per Clamp diode	—	—	0.63		
RGint	Internal gate resistance	Tc = 25°C	—	0	—	Ω	
RG	External gate resistance		6.0	—	62		

CM75RX-24A

HIGH POWER SWITCHING USE

NTC THERMISTOR PART

Symbol	Parameter	Conditions	Limits			Unit
			Min.	Typ.	Max.	
R	Zero power resistance	Tc = 25°C	4.85	5.00	5.15	kΩ
ΔR	Deviation of resistance	Tc = 100°C, R100 = 493Ω	-7.3	—	+7.8	%
B(25/50)	B constant	Approximate by equation (Note. 7)	—	3375	—	K
P25	Power dissipation	Tc = 25°C	—	—	10	mW

MODULE

Symbol	Parameter	Conditions	Limits			Unit
			Min.	Typ.	Max.	
R _{th(c-f)}	Contact thermal resistance (Case to fin) (Note. 1)	Thermal grease applied per 1 module (Note. 2)	—	0.015	—	K/W

- Note. 1: Case temperature (T_C), heat sink temperature (T_f) measured point is just under the chips. (Refer to the figure of the chip location.)
 2: Typical value is measured by using thermally conductive grease of λ = 0.9W/(m·K).
 3: I_E, I_{ERM}, V_{EC}, t_{rr} and Q_{rr} represent ratings and characteristics of the anti-parallel, emitter-collector free wheeling diode (FWDi). I_F, I_{FRM}, V_F, V_{RRM} and I_{RRM} represent ratings and characteristics of the Clamp diode of Brake part.
 4: Pulse width and repetition rate should be such that the device junction temperature (T_j) dose not exceed T_{jmax} rating.
 5: Junction temperature (T_j) should not increase beyond 150°C.
 6: Pulse width and repetition rate should be such as to cause negligible temperature rise. (Refer to the figure of the test circuit for V_{CE(sat)} and V_{EC})
 7: $B(25/50) = \ln\left(\frac{R_{25}}{R_{50}}\right) / \left(\frac{1}{T_{25}} - \frac{1}{T_{50}}\right)$
 R₂₅: resistance at absolute temperature T₂₅ [K]; T₂₅ = 25 [°C]+273.15 = 298.15 [K]
 R₅₀: resistance at absolute temperature T₅₀ [K]; T₅₀ = 50 [°C]+273.15 = 323.15 [K]

Chip Location (Top view)

Dimensions in mm (tolerance: ±1mm)

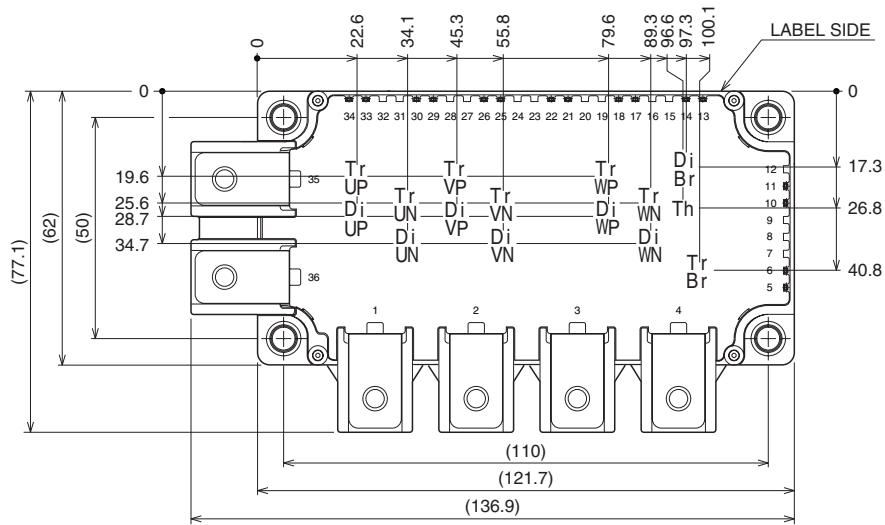

Each mark points the center position of each chip. Tr**: IGBT, Di**: FWDi (DiBr: Clamp diode), Th: NTC thermistor

CM75RX-24A

HIGH POWER SWITCHING USE

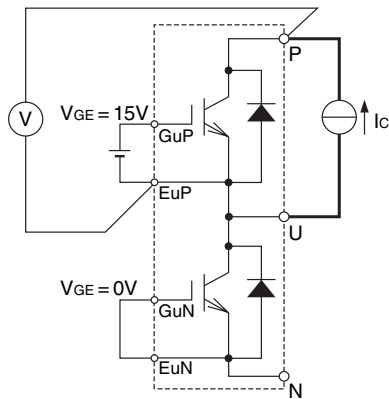

P side Inverter part Tr
(example of U arm)
 $V_{GE} = 0V$ (GvP-EvP, GwP-EwP, GvN-EvN,
GwN-EwN, GB-EB)

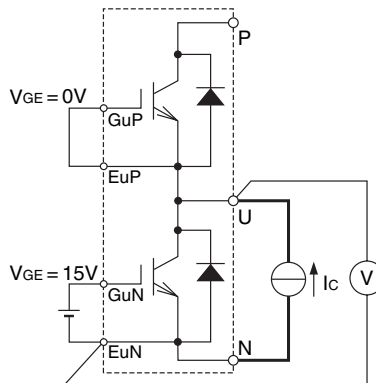

N side Inverter part Tr
(example of U arm)
 $V_{GE} = 0V$ (GvP-EvP, GwP-EwP, GvN-EvN,
GwN-EwN, GB-EB)

VCE(sat) test circuit

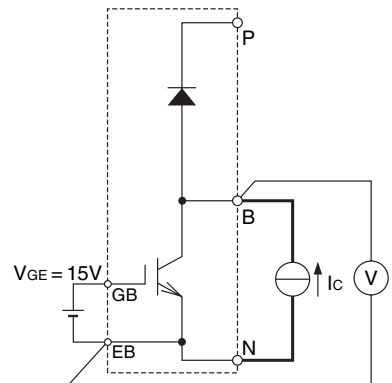

Br Tr
 $V_{GE} = 0V$ (GuP-EuP, GvP-EvP, GwP-EwP,
GuN-EuN, GvN-EvN, GwN-EwN)

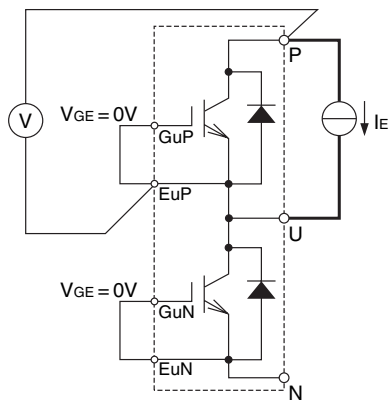

P side Inverter part Di
(example of U arm)
 $V_{GE} = 0V$ (GvP-EvP, GwP-EwP, GvN-EvN,
GwN-EwN, GB-EB)

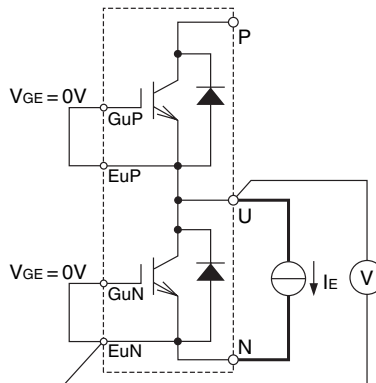

N side Inverter part Di
(example of U arm)
 $V_{GE} = 0V$ (GvP-EvP, GwP-EwP, GvN-EvN,
GwN-EwN, GB-EB)

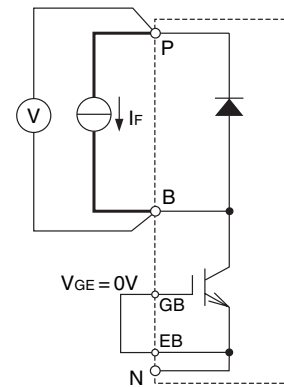

Br Di
 $V_{GE} = 0V$ (GuP-EuP, GvP-EvP, GwP-EwP,
GuN-EuN, GvN-EvN, GwN-EwN)

VEC/VFM test circuit

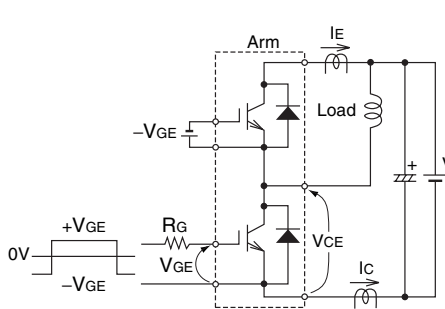

Switching time test circuit and waveforms

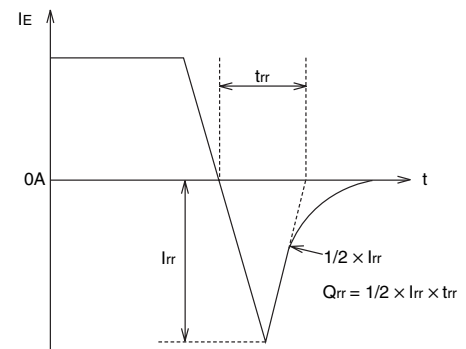
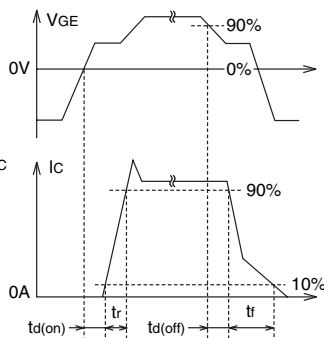

trr, Qrr test waveform

PERFORMANCE CURVES

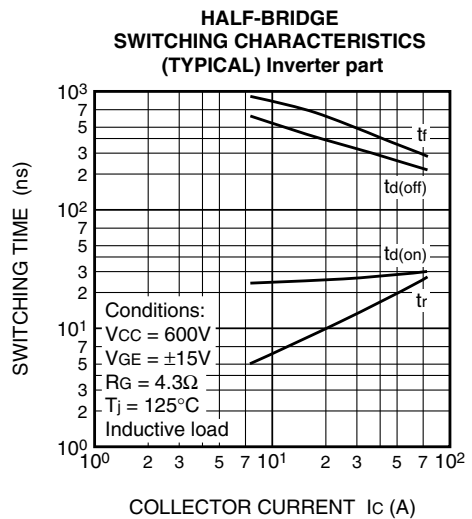
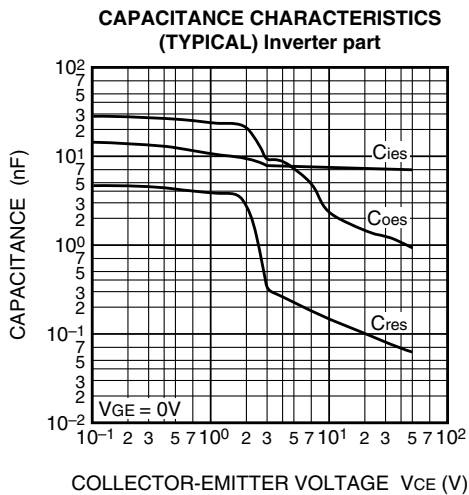
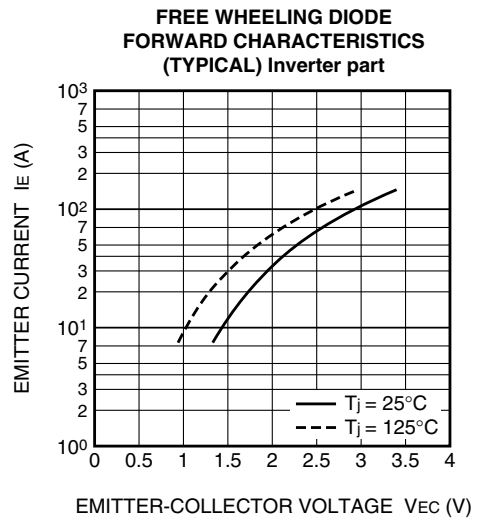
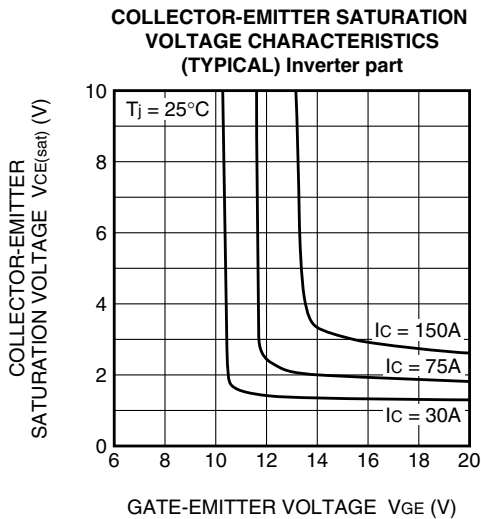
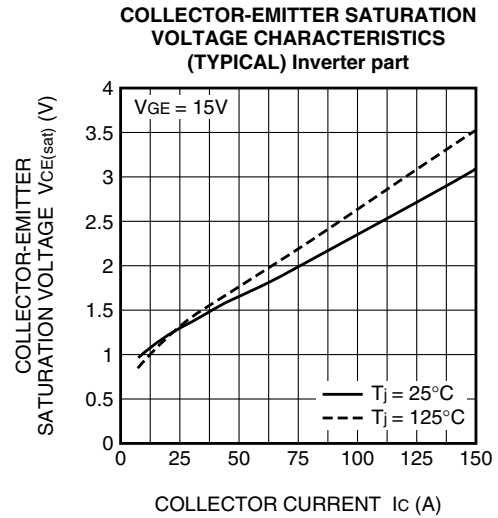
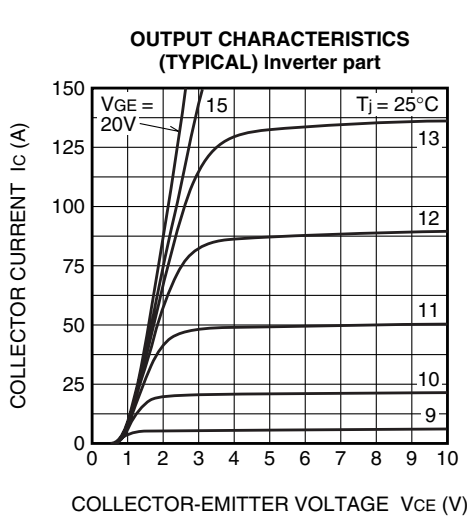

HALF-BRIDGE SWITCHING CHARACTERISTICS (TYPICAL) Inverter part

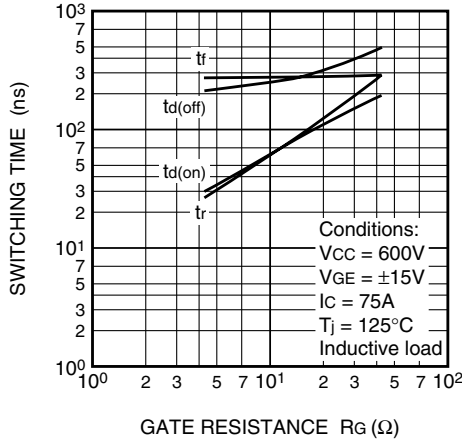

HALF-BRIDGE SWITCHING CHARACTERISTICS (TYPICAL) Inverter part

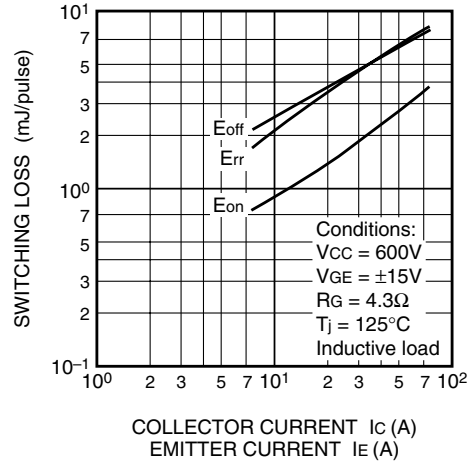

HALF-BRIDGE SWITCHING CHARACTERISTICS (TYPICAL) Inverter part

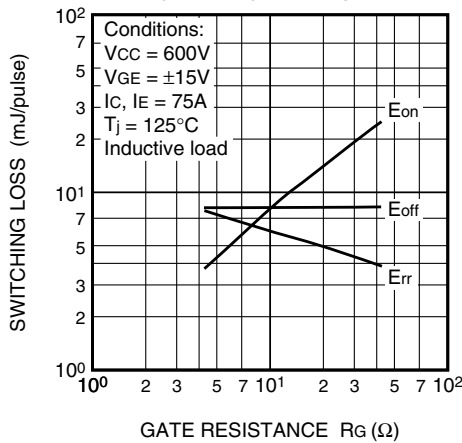

REVERSE RECOVERY CHARACTERISTICS OF FREE WHEELING DIODE (TYPICAL) Inverter part

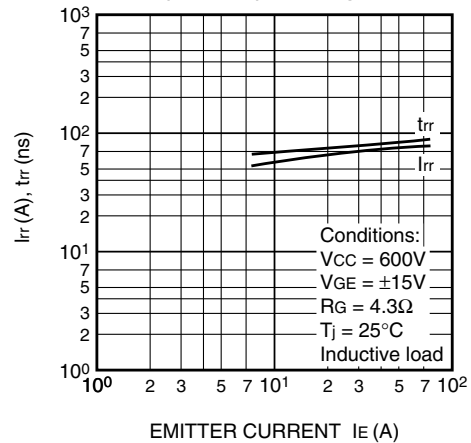

GATE CHARGE CHARACTERISTICS (TYPICAL) Inverter part

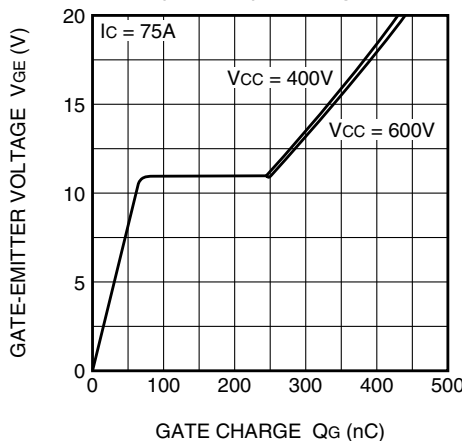

TRANSIENT THERMAL IMPEDANCE CHARACTERISTICS

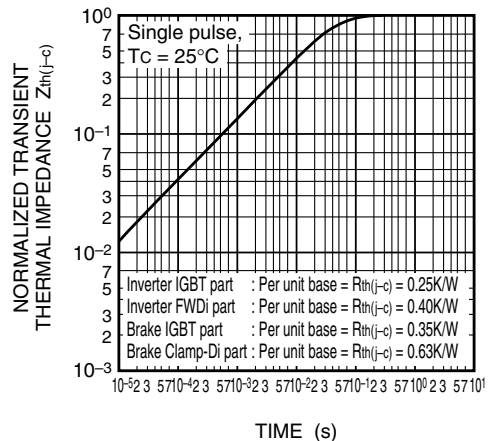

COLLECTOR-EMITTER SATURATION VOLTAGE CHARACTERISTICS (TYPICAL) Brake part

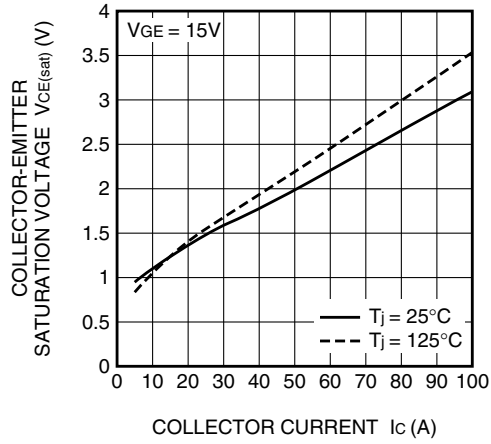

CLAMP DIODE FORWARD CHARACTERISTICS (TYPICAL) Brake part

