

DATA SHEET

SKY13290-313LF: 20 MHz-2.5 GHz, 10 W pHEMT SPDT Switch

Applications

- Transmit/receive switching for telematic systems at elevated power levels

Features

- Broadband frequency range: 20 MHz to 2.5 GHz
- Very low insertion loss, 0.4 dB typical @ 0.9 GHz
- High isolation: 26 dB typical @ 0.9 GHz
- High input power compression: 0.1 dB @ > +40 dBm
- Low current consumption: <100 μ A @ 3 V
- Ultra-miniature, QFN (6-pin, 2 x 3 mm) package (MSL1, 260 °C per JEDEC J-STD-020)

NEW



Skyworks Green™ products are RoHS (Restriction of Hazardous Substances)-compliant, conform to the EIA/EICTA/JEITA Joint Industry Guide (JIG) Level A guidelines, are halogen free according to IEC-61249-2-21, and contain <1,000 ppm antimony trioxide in polymeric materials.

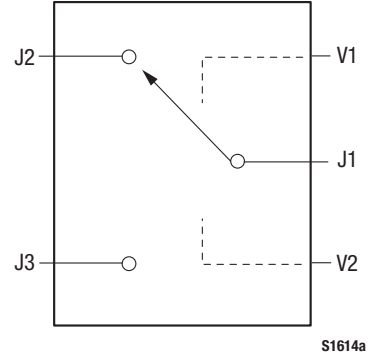

Figure 1. SKY13290-313LF Block Diagram

Description

The SKY13290-313LF is a high power, pHEMT Single Pole Double Throw (SPDT) switch. The switch is designed for use in systems operating from 20 MHz to 2.5 GHz for which low loss, high isolation, low control voltage, and ultra-miniature package size are required.

The device is controlled with positive, negative, or a combination of both voltages. The RF signal paths within the device are fully bilateral.

The SKY13290-313LF is manufactured in a compact, low-cost 2 x 3 mm, 6-pin Quad Flat No-Lead (QFN) package. A functional block diagram is shown in Figure 1. The pin configuration and package are shown in Figure 2. Signal pin assignments and functional pin descriptions are provided in Table 1.

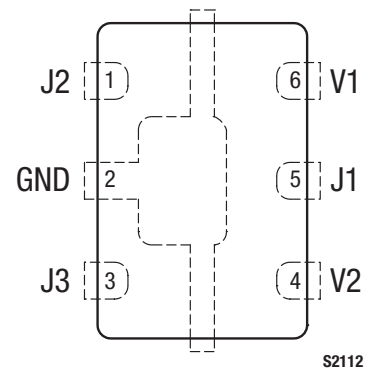

Figure 2. SKY13290-313LF Pinout –6-Pin QFN (Top View)

Table 1. SKY13290-313LF Signal Descriptions

Pin #	Name	Description	Pin #	Name	Description
1	J2	RF input/output. According to the logic voltage levels applied to the V1 and V2 pins, this port is either connected to J1 using a low insertion loss path or isolated from J1 (Note 1).	4	V2	DC control voltage input #2. The logic voltage applied to this pin, along with the voltage level applied to the V1 pin, determines the states of the RF paths between J1/J2 and J1/J3.
2	GND	Ground. Equipotential port, internal circuit common, which must be connected to the PCB ground or common using the lowest possible impedance.	5	J1	RF input/output. According to the logic voltage levels applied to the V1 and V2 pins, this port is either connected to J2 or to J3 using a low insertion loss path and isolated from the other RF port (Note 1).
3	J3	RF input/output. According to the logic voltage levels applied to the V1 and V2 pins, this port is either connected to J1 using a low insertion loss path or isolated from J1 (Note 1).	6	V1	DC control voltage input #1. The logic voltage applied to this pin, along with the voltage level applied to the V2 pin, determines the states of the RF paths between J1/J2 and J1/J3.

Note 1: A 47 pF blocking capacitor is required for >500 MHz operation. Use larger value capacitors for lower frequency operation.

Table 2. SKY13290-313LF Absolute Maximum Ratings

Parameter	Symbol	Minimum	Maximum	Units
Control voltage	V _{CTL}	0	+10	V
RF input power (V _{CTL} > 0.9 GHz)	P _{IN}		+43.5	dBm
Operating temperature	T _{OP}	-40	+85	°C
Storage temperature	T _{STG}	-65	+150	°C

Note: Exposure to maximum rating conditions for extended periods may reduce device reliability. There is no damage to device with only one parameter set at the limit and all other parameters set at or below their nominal value.

CAUTION: Although this device is designed to be as robust as possible, Electrostatic Discharge (ESD) can damage this device. This device must be protected at all times from ESD. Static charges may easily produce potentials of several kilovolts on the human body or equipment, which can discharge without detection. Industry-standard ESD precautions should be used at all times.

Technical Description

The SKY13290-313LF is controlled using two voltage inputs, V1 and V2 (pins 6 and 4, respectively). Depending on the voltage level applied to these pins, the common RF port (J1) is connected to one of two RF ports (J2 or J3) using a low insertion loss path, while the path between J1 and the other RF port is in its isolation state.

When the control voltages are toggled, the states between J1 and J2, as well as J1 and J3, are also toggled.

Electrical and Mechanical Specifications

The absolute maximum ratings of the SKY13290-313LF are provided in Table 2. Electrical specifications are provided in Table 3 and the operating characteristics are specified in Table 4. Typical performance characteristics of the SKY13290-313LF are illustrated in Figures 3 through 6.

The state of the SKY13290-313LF is determined by the logic provided in Table 5.

Table 3. SKY13290-313LF Electrical Specifications (Note 1)

($V_{CTL} = 0-3\text{ V}$, $T_{OP} = +25\text{ }^{\circ}\text{C}$, $P_{IN} = 0\text{ dBm}$, Characteristic Impedance = $50\ \Omega$, Unless Otherwise Noted)

Parameter	Symbol	Test Condition	Min	Typical	Max	Units
Insertion loss		0.02 to 1.0 GHz		0.40	0.50	dB
		1.0 to 2.0 GHz		0.45	0.60	dB
		2.0 to 2.5 GHz		0.55	0.70	dB
Isolation		0.02 to 1.0 GHz	23	26		dB
		1.0 to 2.0 GHz	17	20		dB
		2.0 to 2.5 GHz	15	18		dB
Return loss (Note 2)		0.02 to 1.0 GHz		20		dB
		1.0 to 2.5 GHz		20		dB
Switching characteristics: Rise/fall		10/90% or 90/10% RF		650		ns
		On/off		800		ns
0.1 dB Input Compression Point	IPO.1dB	@ 48 MHz		+37.6		dBm
		@ 900 MHz		+40.5		dBm
Thermal resistance				45		$^{\circ}\text{C}/\text{W}$
Control voltage: Low (@ 20 μA max) High (@100 μA max) High (@ 200 μA max)	V_{CTL_L}		0			V
	V_{CTL_H}				2.7	V
	V_{CTL_H}				10.0	V

Note 1: Performance is guaranteed only under the conditions listed in this Table.

Note 2: Return loss state. Lower frequency return loss is dependent on value of the DC blocking capacitors.

Typical Performance Characteristics

($V_{CTL} = 0-3\text{ V}$, $T_{OP} = +25\text{ }^{\circ}\text{C}$, $P_{IN} = 0\text{ dBm}$, Characteristic Impedance [Z_0] = $50\ \Omega$, $C_{BL} = 100\text{ pF}$, Unless Otherwise Noted)

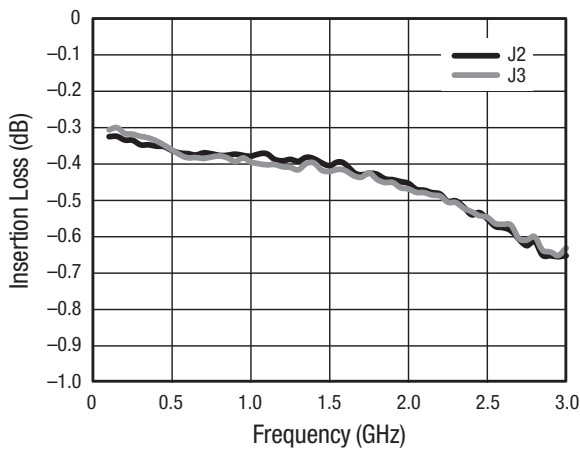

Figure 3. Insertion Loss vs Frequency

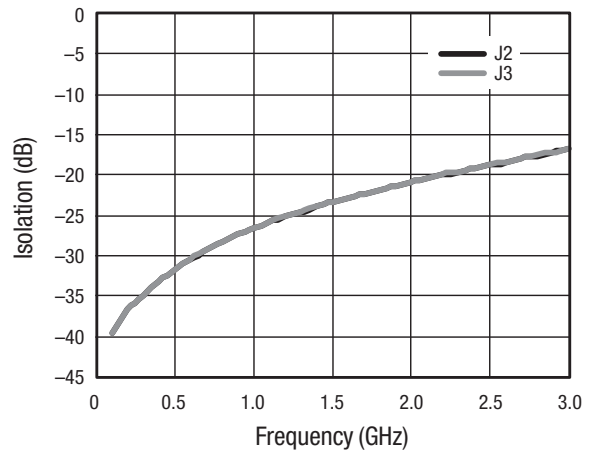

Figure 4. Isolation vs Frequency

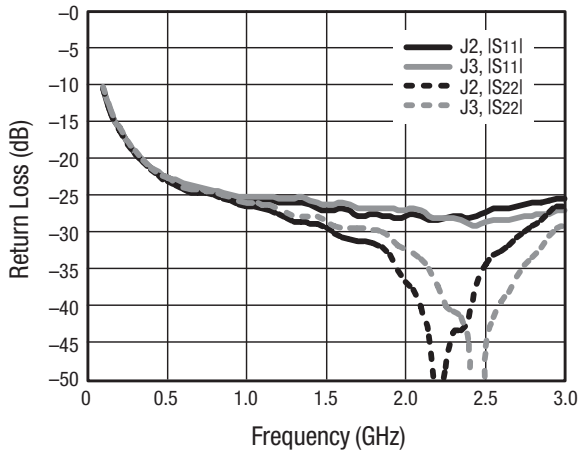

Figure 5. Return Loss vs Frequency (Insertion Loss State)

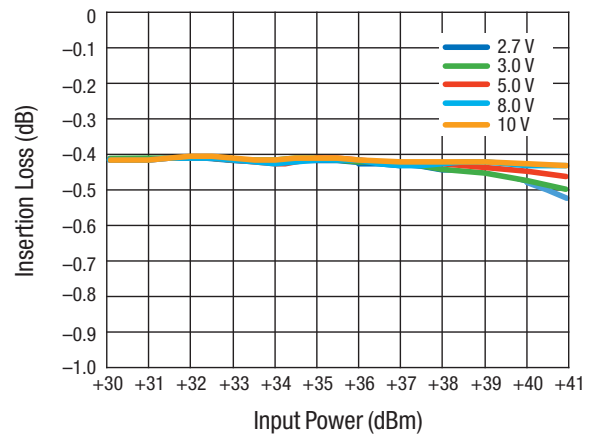

Figure 6. Insertion Loss vs Input Power (@ 900 MHz)

Table 4. Truth Table ($V_{HIGH} = 2$ to 5 V)

V1	V2	J1-J2	J1-J3
V_{LOW}	V_{HIGH}	Isolation	Insertion loss
V_{HIGH}	V_{LOW}	Insertion loss	Isolation

Note: $V_{LOW} = 0$ to 0.2 V, $V_{HIGH} = 2.7$ to 10 V. Any state other than described in this Table places the device in an undefined state. An undefined state does not damage the device.

Evaluation Board Description

The SKY13290-313LF Evaluation Board is used to test the performance of the SKY13290-313LF SPDT switch. An Evaluation Board schematic diagram is provided in Figure 7. An assembly drawing for the Evaluation Board is shown in Figure 8.

Package Dimensions

The PCB layout footprint for the SKY13290-313LF is shown in Figure 9. Package dimensions for the 6-pin QFN are shown in Figure 10, and tape and reel dimensions are provided in Figure 11.

Package and Handling Information

Instructions on the shipping container label regarding exposure to moisture after the container seal is broken must be followed. Otherwise, problems related to moisture absorption may occur when the part is subjected to high temperature during solder assembly.

The SKY13290-313LF is rated to Moisture Sensitivity Level 1 (MSL1) at 260°C . It can be used for lead or lead-free soldering.

Care must be taken when attaching this product, whether it is done manually or in a production solder reflow environment. Production quantities of this product are shipped in a standard tape and reel format.

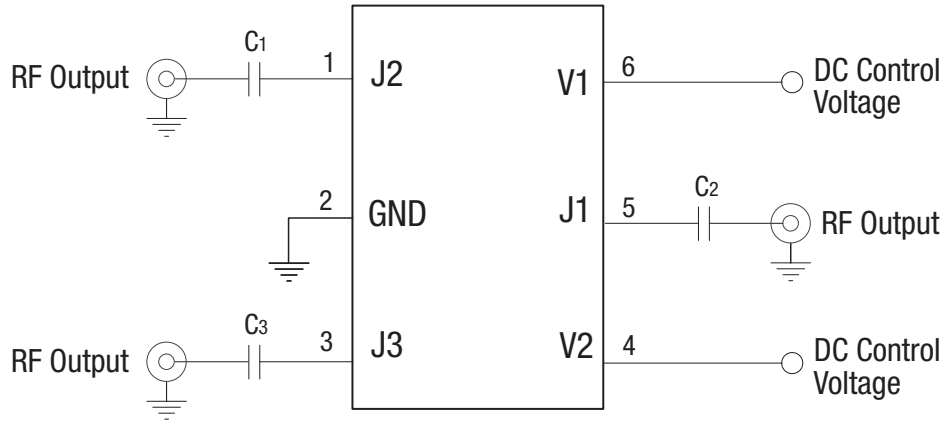

Note: Use 47 pF blocking capacitors (C1, C2, C3) for >500 MHz operation. Higher values recommended for lower frequency operation. Exposed paddle must be grounded.
 Use 10 nF blocking capacitors (C1, C2, C3) for <50 MHz operation.

S2114

Figure 7. SKY13290-313LF Evaluation Board Schematic

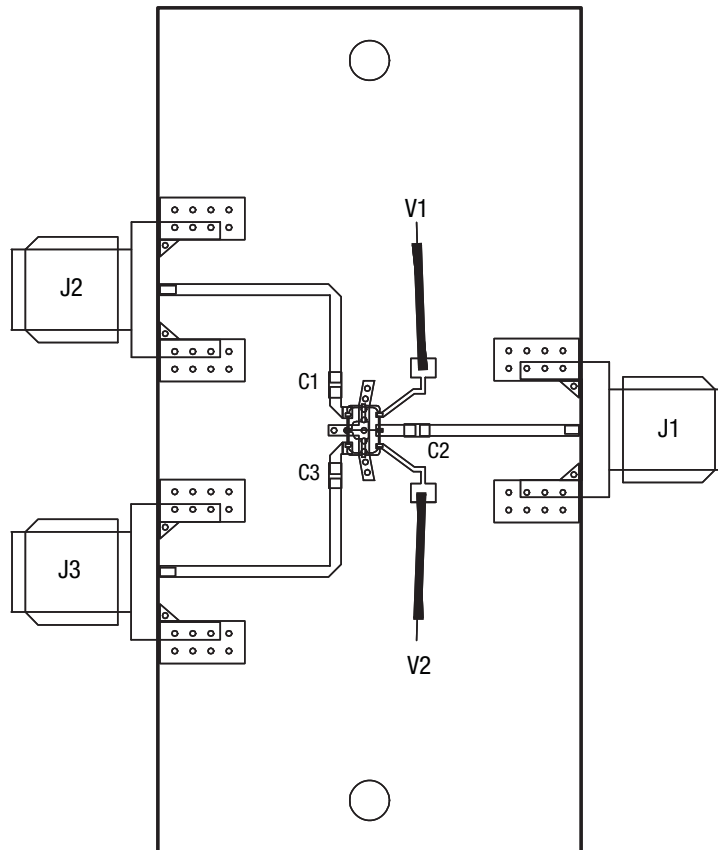

S2113

Figure 8. SKY13290-313LF Evaluation Board Assembly Diagram

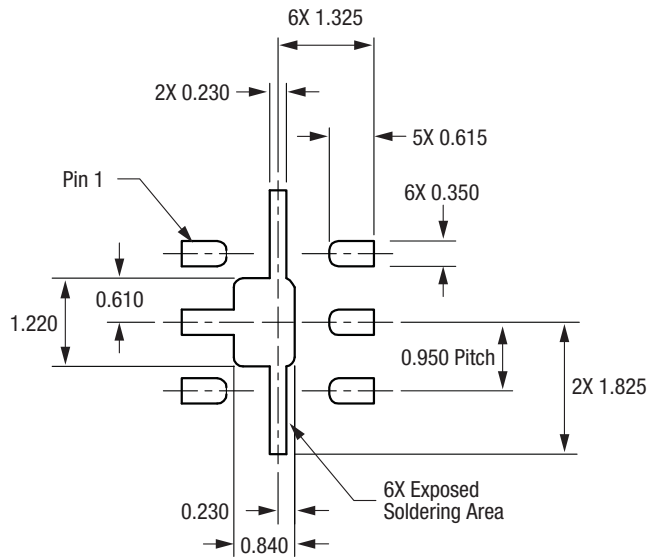

All dimensions are in millimeters

S2115

Figure 9. SKY13290-313LF PCB Layout Footprint

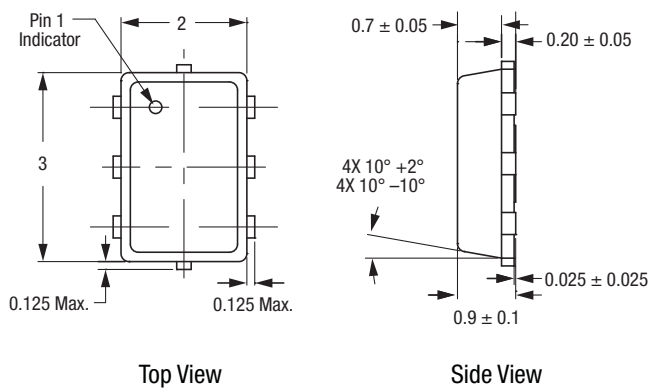

Top View

Side View

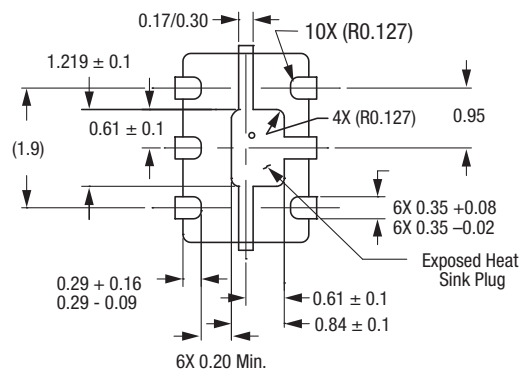

Bottom View

S2111

Figure 10. SKY13290-313LF 6-Pin QFN Package Dimensions

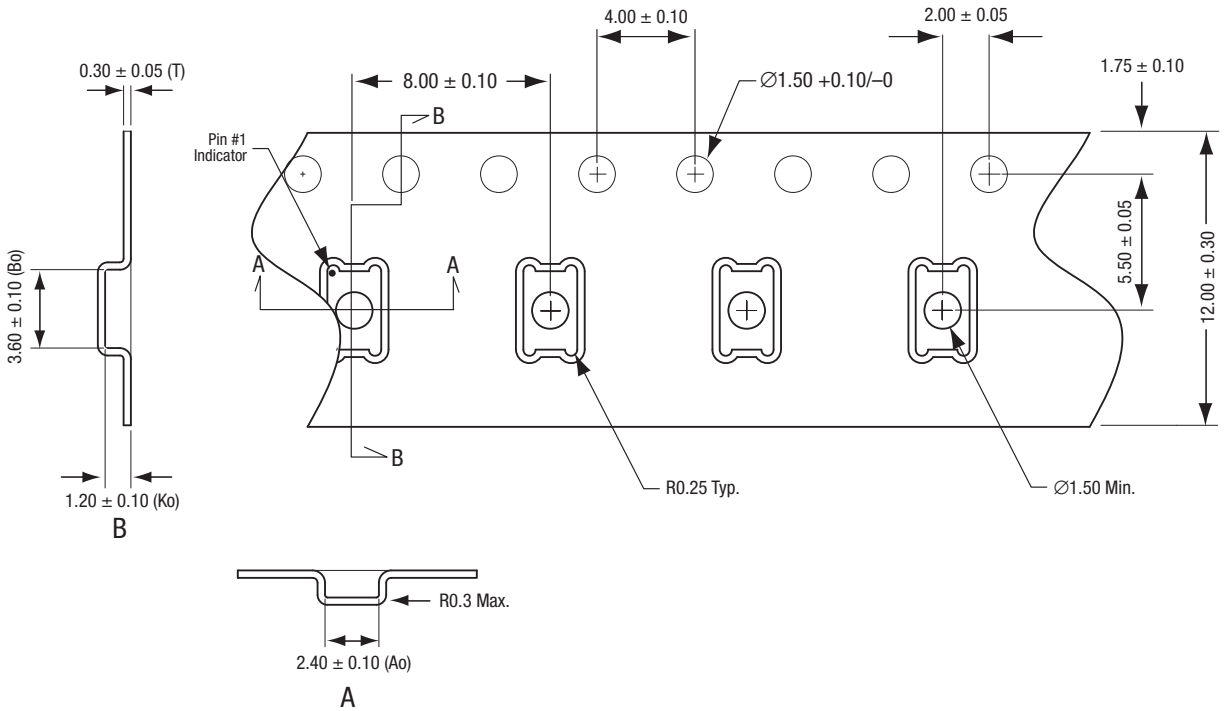

Notes:

1. Carrier tape: black conductive polystyrene, non-bakeable material.
2. Cover tape material: transparent conductive HSA with 9.20 mm width.
3. ESD-surface resistivity is $\geq 1 \times 10^9 \sim \leq 1 \times 10^{10}$ Ohms/square per EIA, JEDEC TNR Specification.
4. All measurements are in millimeters.

S2116

Figure 11. SKY13290-313LF Tape and Reel Dimensions

Ordering Information

Model Name	Manufacturing Part Number	Evaluation Board Part Number
SKY13290-313LF SPDT Switch	SKY13290-313LF	SKY13290-313LF-EVB

Copyright © 2002-2007, 2010 Skyworks Solutions, Inc. All Rights Reserved.

Information in this document is provided in connection with Skyworks Solutions, Inc. ("Skyworks") products or services. These materials, including the information contained herein, are provided by Skyworks as a service to its customers and may be used for informational purposes only by the customer. Skyworks assumes no responsibility for errors or omissions in these materials or the information contained herein. Skyworks may change its documentation, products, services, specifications or product descriptions at any time, without notice. Skyworks makes no commitment to update the materials or information and shall have no responsibility whatsoever for conflicts, incompatibilities, or other difficulties arising from any future changes.

No license, whether express, implied, by estoppel or otherwise, is granted to any intellectual property rights by this document. Skyworks assumes no liability for any materials, products or information provided hereunder, including the sale, distribution, reproduction or use of Skyworks products, information or materials, except as may be provided in Skyworks Terms and Conditions of Sale.

THE MATERIALS, PRODUCTS AND INFORMATION ARE PROVIDED "AS IS" WITHOUT WARRANTY OF ANY KIND, WHETHER EXPRESS, IMPLIED, STATUTORY, OR OTHERWISE, INCLUDING FITNESS FOR A PARTICULAR PURPOSE OR USE, MERCHANTABILITY, PERFORMANCE, QUALITY OR NON-INFRINGEMENT OF ANY INTELLECTUAL PROPERTY RIGHT; ALL SUCH WARRANTIES ARE HEREBY EXPRESSLY DISCLAIMED. SKYWORKS DOES NOT WARRANT THE ACCURACY OR COMPLETENESS OF THE INFORMATION, TEXT, GRAPHICS OR OTHER ITEMS CONTAINED WITHIN THESE MATERIALS. SKYWORKS SHALL NOT BE LIABLE FOR ANY DAMAGES, INCLUDING BUT NOT LIMITED TO ANY SPECIAL, INDIRECT, INCIDENTAL, STATUTORY, OR CONSEQUENTIAL DAMAGES, INCLUDING WITHOUT LIMITATION, LOST REVENUES OR LOST PROFITS THAT MAY RESULT FROM THE USE OF THE MATERIALS OR INFORMATION, WHETHER OR NOT THE RECIPIENT OF MATERIALS HAS BEEN ADVISED OF THE POSSIBILITY OF SUCH DAMAGE.

Skyworks products are not intended for use in medical, lifesaving or life-sustaining applications, or other equipment in which the failure of the Skyworks products could lead to personal injury, death, physical or environmental damage. Skyworks customers using or selling Skyworks products for use in such applications do so at their own risk and agree to fully indemnify Skyworks for any damages resulting from such improper use or sale.

Customers are responsible for their products and applications using Skyworks products, which may deviate from published specifications as a result of design defects, errors, or operation of products outside of published parameters or design specifications. Customers should include design and operating safeguards to minimize these and other risks. Skyworks assumes no liability for applications assistance, customer product design, or damage to any equipment resulting from the use of Skyworks products outside of stated published specifications or parameters.

Skyworks, the Skyworks symbol, and "Breakthrough Simplicity" are trademarks or registered trademarks of Skyworks Solutions, Inc., in the United States and other countries. Third-party brands and names are for identification purposes only, and are the property of their respective owners. Additional information, including relevant terms and conditions, posted at www.skyworksinc.com, are incorporated by reference.