

THE INFORMATION CONTAINED HEREIN IS CONSIDERED "PROPRIETARY" TO BEL FUSE INC. AND SHALL NOT BE COPIED, REPRODUCED OR DISCLOSED WITHOUT THE WRITTEN APPROVAL OF BEL FUSE INC.

LED1 POLARITY			LED2 POLARITY		
PIN 13	PIN 14	COLOR	PIN 15	PIN 16	COLOR
-	+	YELLOW	+	-	ORANGE
/	/	/	-	+	GREEN

RoHS
2002/95/EC



ELECTRICAL CHARACTERISTICS @ 25°C

URNS RATIO

TP1	1CT : 1CT ±2%
TP2	1CT : 1CT ±2%
TP3	1CT : 1CT ±2%
TP4	1CT : 1CT ±2%

QCL @ 100kHz/100mVRMS

8mA DC BIAS	350µH MIN.
-------------	------------

INS. LOSS

0.1MHz TO 1MHz	-1.1 dB MAX
1MHz TO 65MHz	-0.5 dB MAX
65MHz TO 100MHz	-0.8 dB MAX
100MHz TO 125MHz	-1.2 dB MAX

RET. LOSS (MIN)

0.5MHz-40MHz	-18 dB
40MHz-100MHz	-12+20LOG(f/80MHz) dB

CROSS TALK

100kHz - 100MHz	-33+20LOG(f/100MHz)dB MIN
-----------------	---------------------------

CM TO CM REJ

100kHz - 100MHz	-30 dB MIN
-----------------	------------

CM TO DM REJ

100kHz - 100MHz	-35 dB MIN
-----------------	------------

HIPOT (Isolation Voltage):

1500 Vrms

100% OF PRODUCTION TESTED TO COMPLY WITH IEEE 802.3 ISOLATION REQUIREMENTS.

LED 1

VF (FORWARD VOLTAGE)	IF=20mA	YELLOW	2.1V TYP.
λ D (DOMINANT WAVELENGTH)	IF=20mA	YELLOW	590nm TYP.

LED 2

VF (FORWARD VOLTAGE)	IF=20mA	GREEN	2.2V TYP.
		ORANGE	2.0V TYP.
λ D (DOMINANT WAVELENGTH)	IF=20mA	GREEN	565nm TYP.
		ORANGE	610nm TYP.

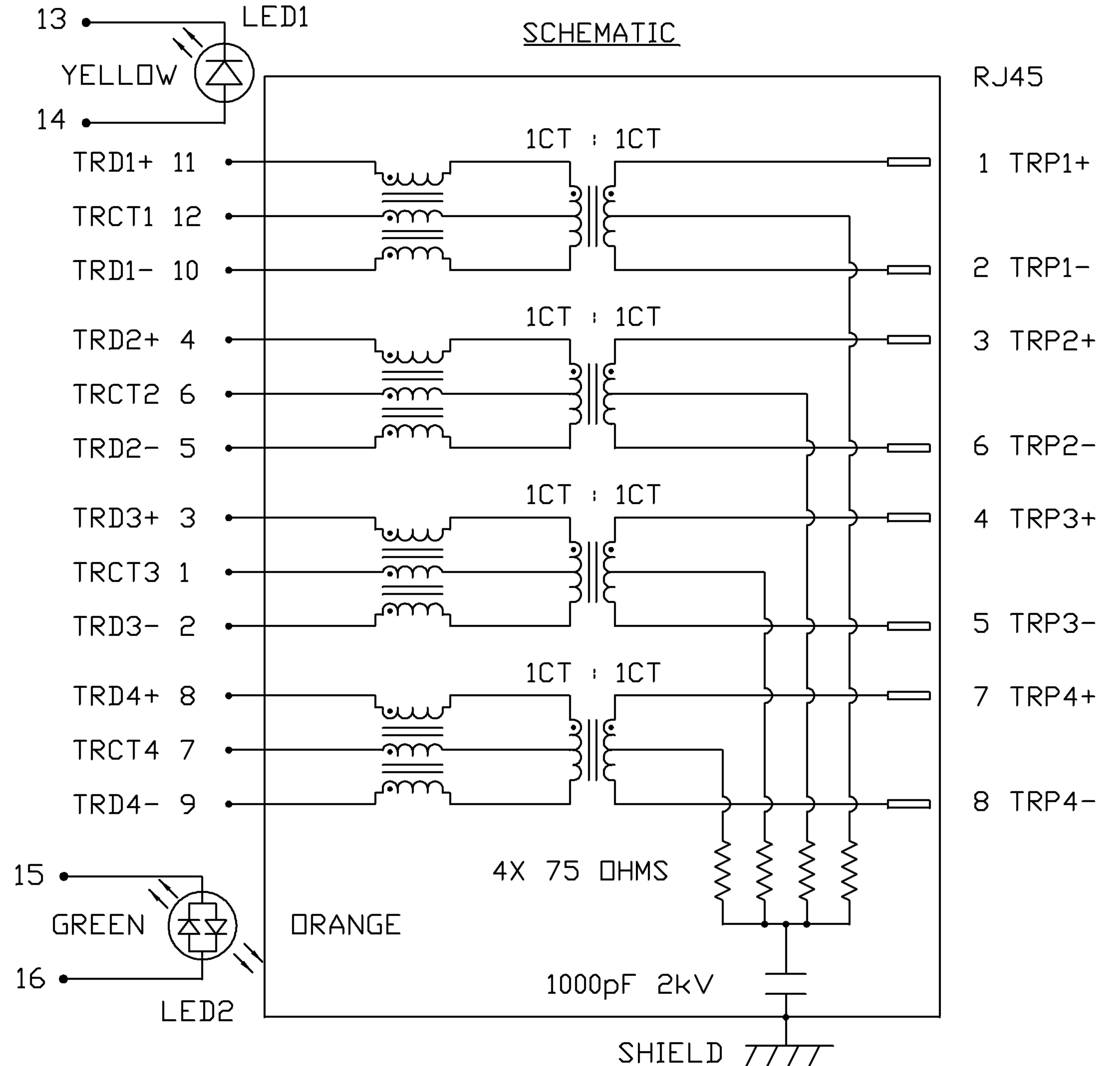

ORIGINATED BY	DATE
CHOW WANGCHUNG	07-28-08
DRAWN BY	DATE
LI YONGFENG	07-28-08

TITLE
gigabit MagJack® (8 cores, Tab Up) 0826-1XX1-43-F

PART NO. / DRAWING NO.
08261XX143-F
FILE NAME
08261XX143-F_B.DWG

STANDARD DIM.
TOL. IN INCH
.X
.XX
.XXX

[] METRIC DIM. AS REFERENCE
UNIT : INCH [mm]
SCALE : N/A
REV. : B
SIZE : A4
PAGE : 2



THE INFORMATION CONTAINED HEREIN IS CONSIDERED "PROPRIETARY" TO BEL FUSE INC. AND SHALL NOT BE COPIED, REPRODUCED OR DISCLOSED WITHOUT THE WRITTEN APPROVAL OF BEL FUSE INC.

RoHS
2002/95/EC

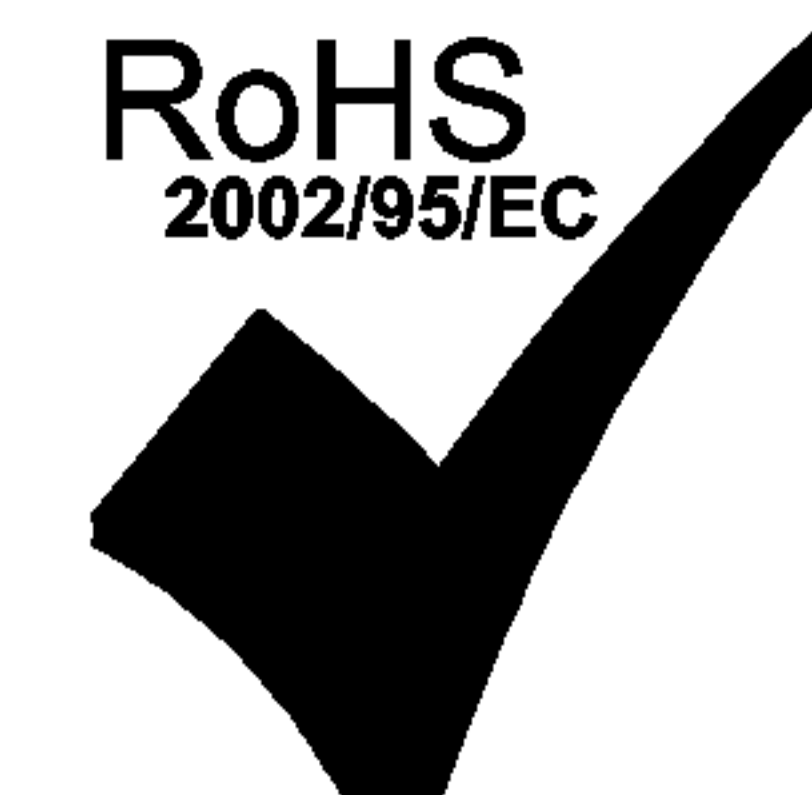

MECHANICAL SPECIFICATION

RECOMMENDED PCB FOOTPRINT

COMPONENT SIDE VIEW

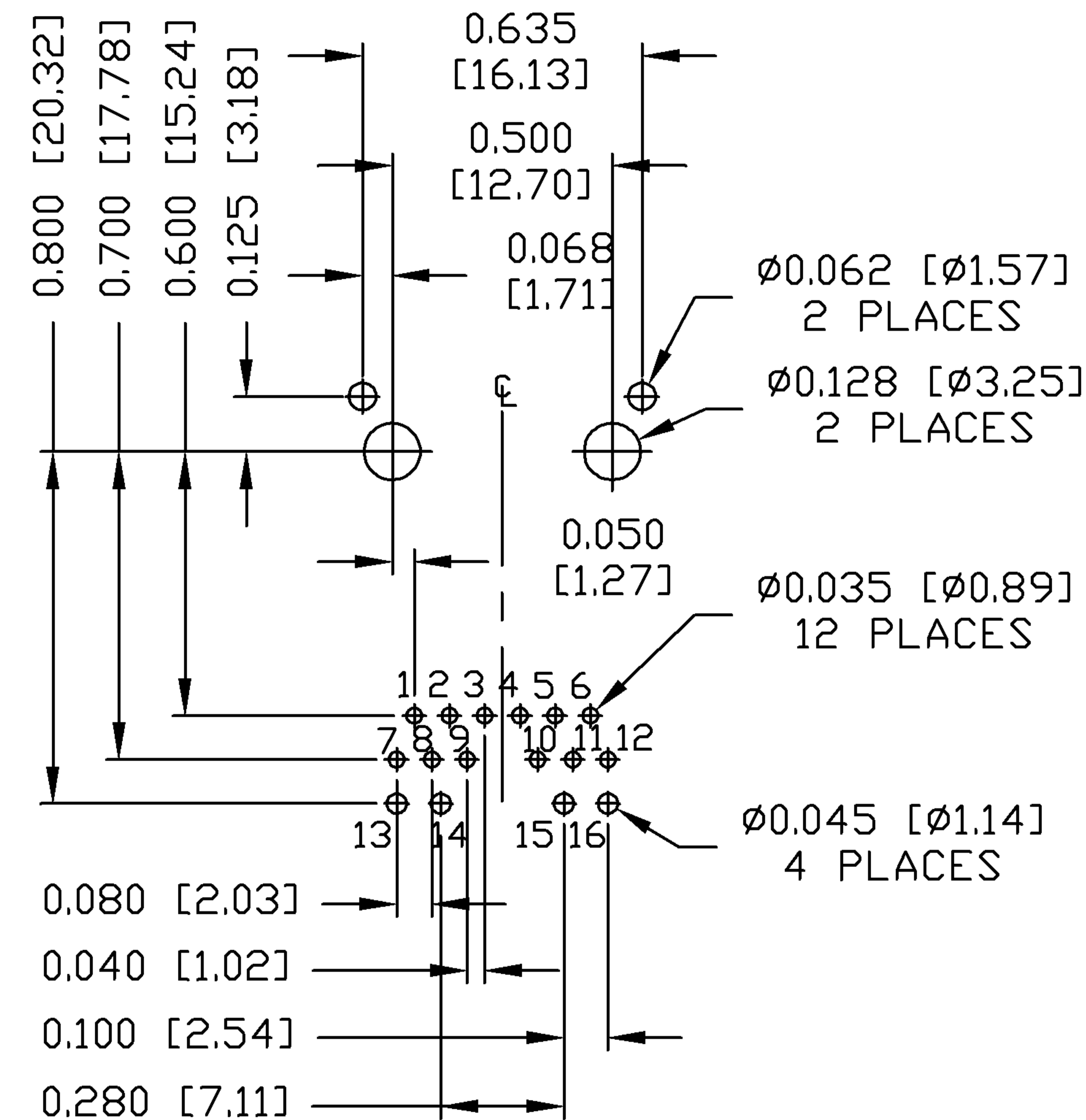
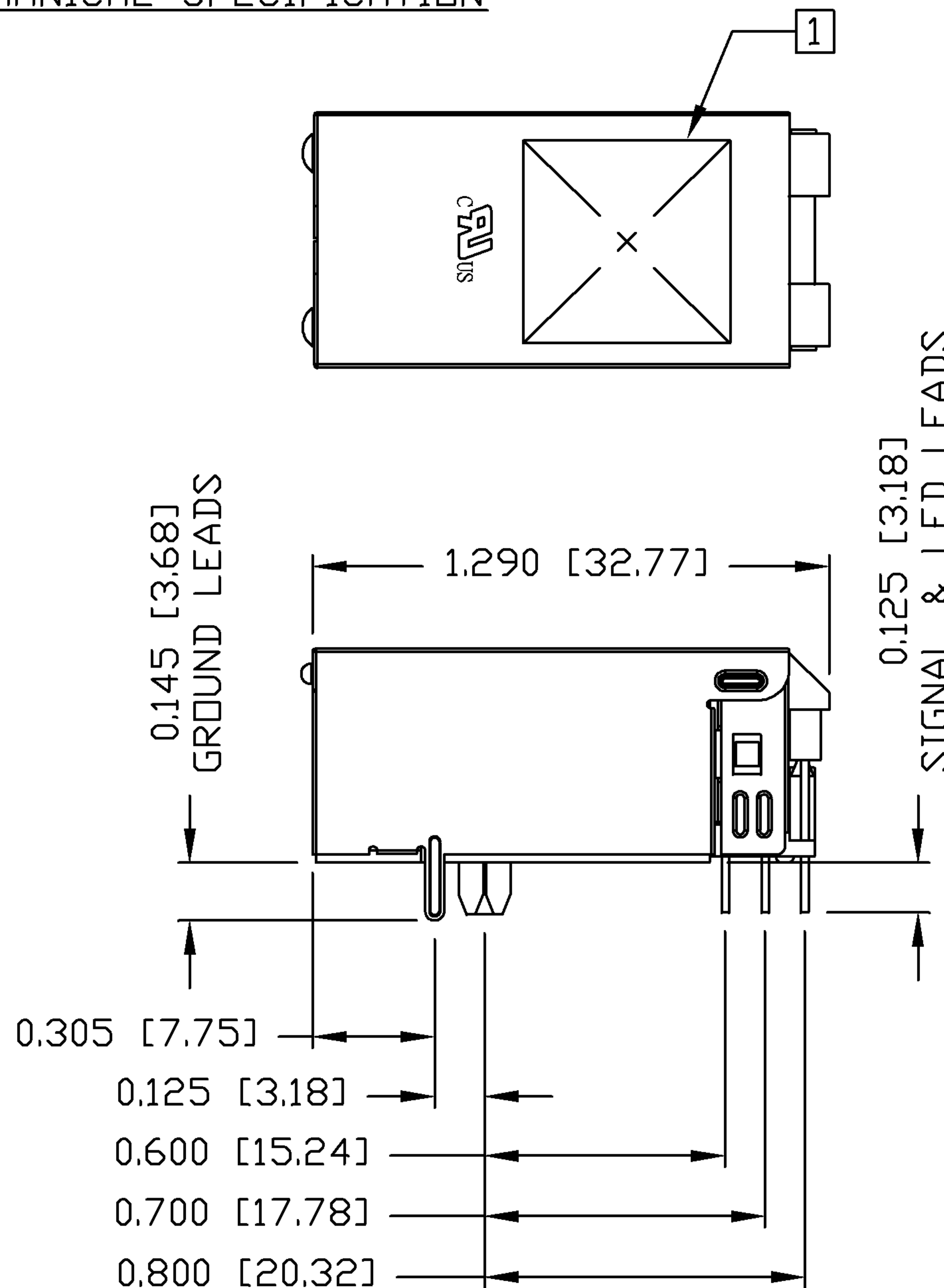
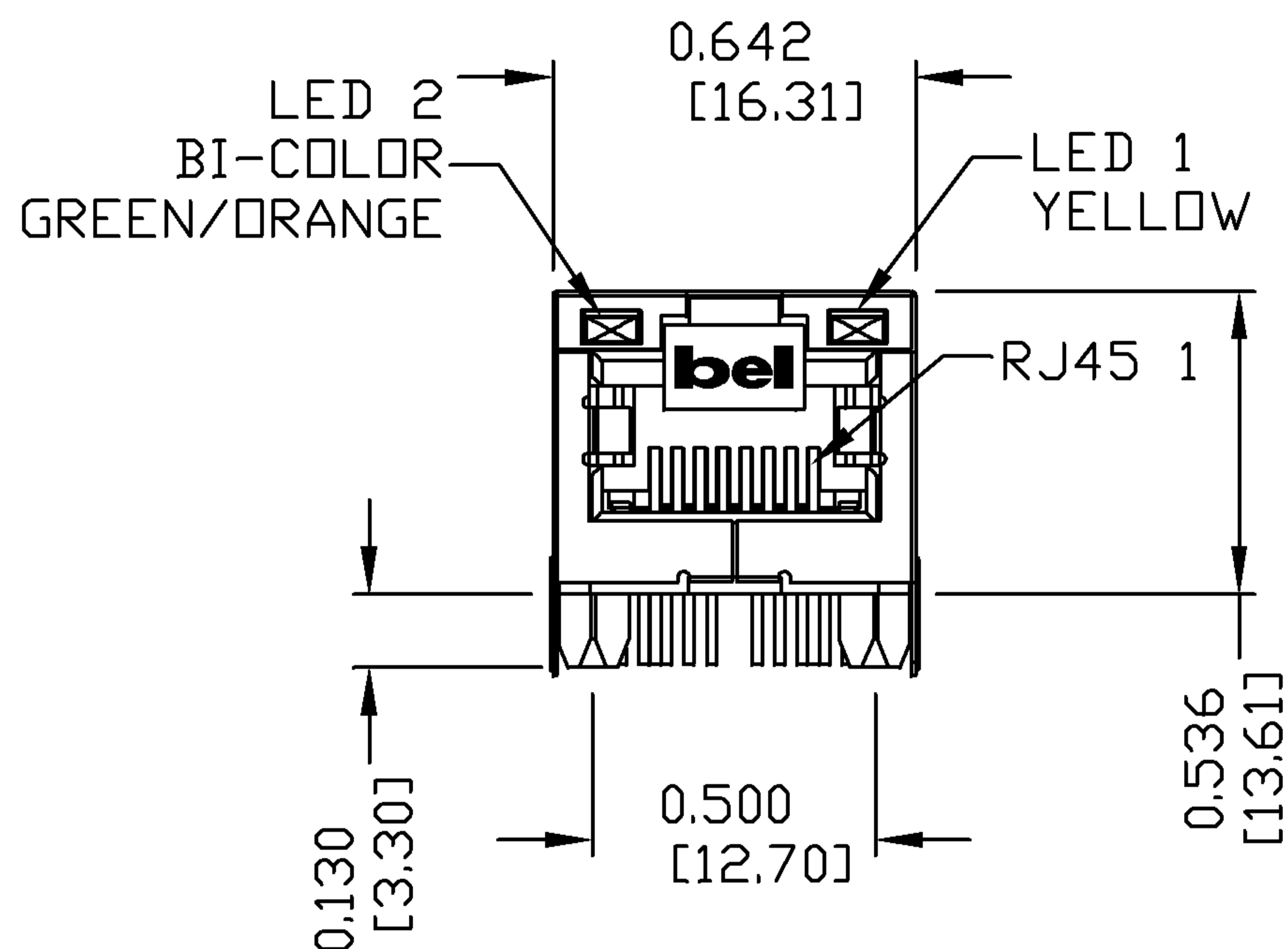

NOTES:

PLASTIC HOUSING: THERMOPLASTIC PA
FLAMMABILITY RATING UL 94V-0
CONTACTS: 50 MICRO-INCH HARD GOLD PLATING
OUTPUT PINS: TIN-COATED COPPER WIRE, DIA 0.018 INCH.
METAL SHIELD: NICKEL PLATED ON COPPER ALLOY.
(ALL GROUND LEADS ARE SOLDER DIPPED)

1. MARK PART WITH MFG LOGO, MFG NAME, PART NUMBER, AND DATE CODE.

UL US UL RECOGNIZED - FILE #E196366 AND E169987.
RoHS COMPLIANT, PER EU DIRECTIVE 2002/95/EC
JACK CAVITY CONFORMS TO FCC RULES AND REGULATIONS.

ORIGINATED BY ZX HUANG	DATE 07-28-08	TITLE gigabit MagJack® (8 cores, Tab Up)	PART NO. / DRAWING NO. 08261XX143-F	STANDARD DIM. TOL. IN INCH	[] METRIC DIM. AS REFERENCE	 COMPONENTS FOR A CONNECTED PLANET
DRAWN BY BL CHEN	DATE 07-28-08	FILE NAME 08261XX143-F_B.DWG	.X	UNIT : INCH [mm]	REV. : B	
			.XX	SCALE : N/A	SIZE : A4	
			.XXX ±0.010		PAGE : 3	

THE INFORMATION CONTAINED HEREIN IS CONSIDERED "PROPRIETARY" TO BEL FUSE INC. AND SHALL NOT BE COPIED, REPRODUCED OR DISCLOSED WITHOUT THE WRITTEN APPROVAL OF BEL FUSE INC.

RoHS
2002/95/EC

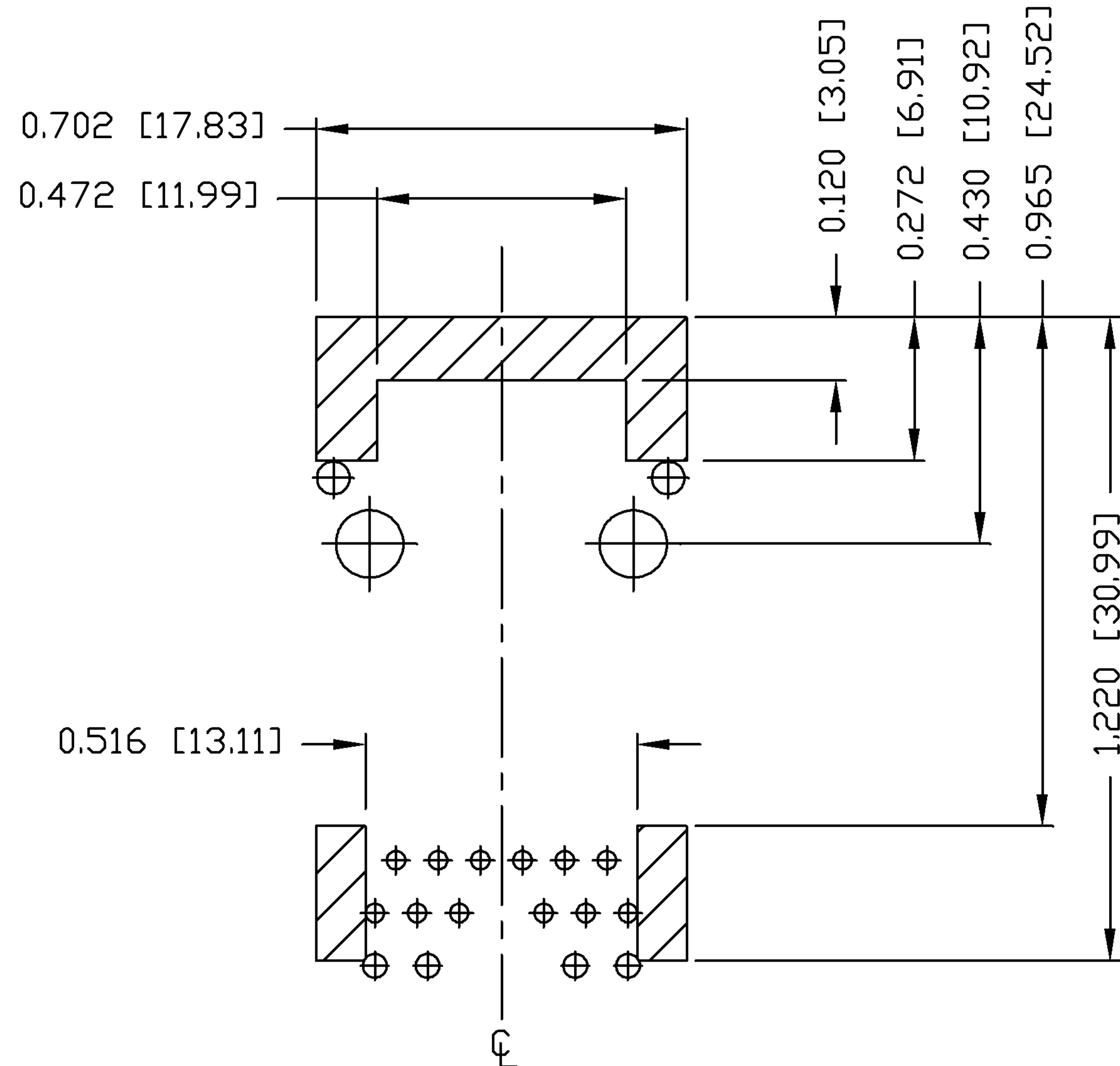
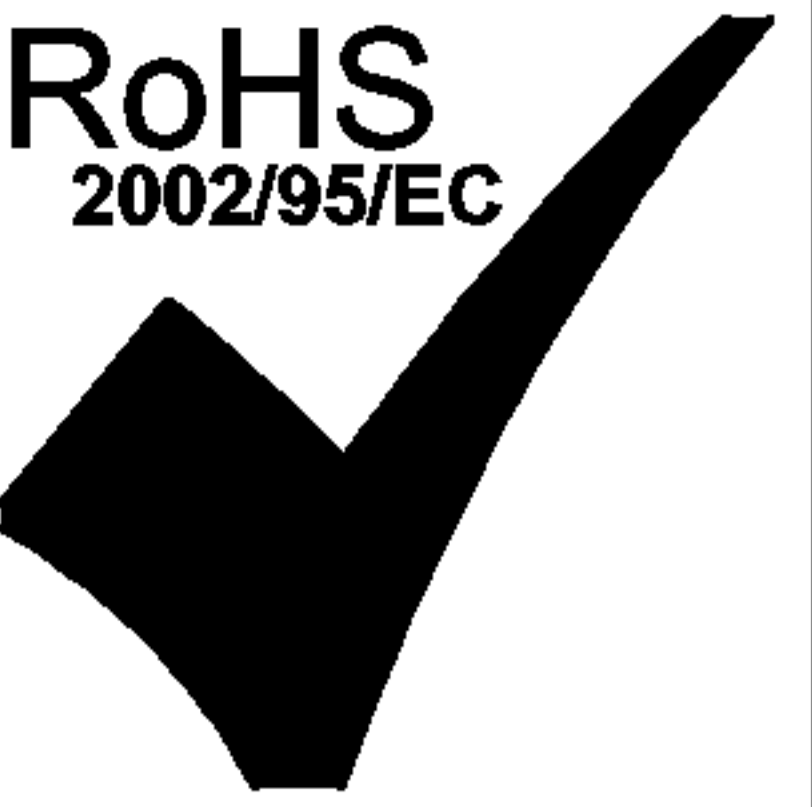

NOTES

THE SHADED AREA ON THE CUSTOMER BOARD ARE RECOMMENDED TO BE CLEAR OFF ANY VIA HOLE OR COMPONENT PAD.

ORIGINATED BY ZX HUANG	DATE 07-28-08	TITLE gigabit MagJack® (8 cores, Tab Up) 0826-1XX1-43-F	PART NO. / DRAWING NO. 08261XX143-F	STANDARD DIM. TOL. IN INCH	[] METRIC DIM. AS REFERENCE	
DRAWN BY BL CHEN	DATE 07-28-08		FILE NAME 08261XX143-F_B.DWG	.X	UNIT : INCH [mm]	REV. : B
				.XX	SCALE : N/A	SIZE : A4
				.XXX ±0.004		PAGE : 4



THE INFORMATION CONTAINED HEREIN IS CONSIDERED "PROPRIETARY" TO BEL FUSE INC. AND SHALL NOT BE COPIED, REPRODUCED OR DISCLOSED WITHOUT THE WRITTEN APPROVAL OF BEL FUSE INC.

RoHS
2002/95/EC

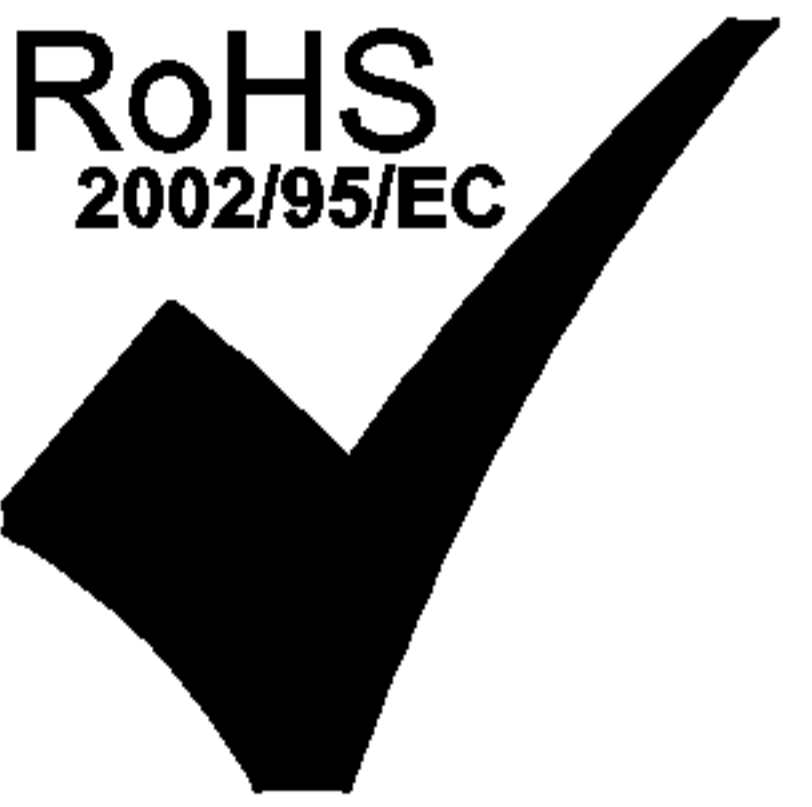

SUGGESTED PANEL OPENING

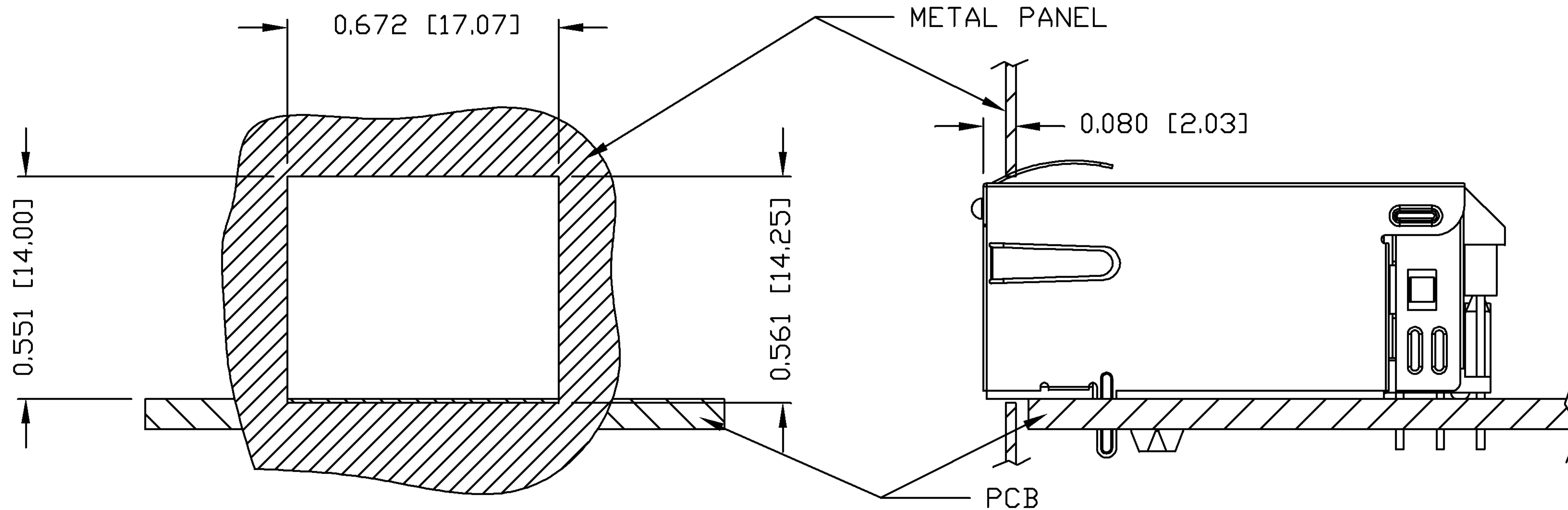

NOTE:

THE DISTANCE OF PANEL INSIDE SURFACE RELATIVE TO FRONT SURFACE OF PART IS ONLY A SUGGESTION. IN CASE THIS DISTANCE IS DIFFERENT, THE REQUIRED PANEL OPENING DIMENSIONS CHANGE ACCORDINGLY.

PACKING INFORMATION

PACKING TRAY : 0200-9999-F6 (TOP)
0200-9999-F7 (BOTTOM)

PACKING QUANTITY : 40 PCS FINISHED GOODS PER TRAY
10 TRAYS (400 PCS FINISHED GOODS) PER CARTON BOX

NOTE : CARDBOARDS ARE PLACED BETWEEN LAYERS OF PACKING TRAY INSIDE CARTON BOX
(INCLUDE THE UPPERMOST AND LOWERMOST TRAY)

ORIGINATED BY ZX HUANG	DATE 07-28-08	TITLE gigabit MagJack® (8 cores, Tab Up) 0826-1XX1-43-F	PART NO. / DRAWING NO. 08261XX143-F		STANDARD DIM. TOL. IN INCH		[] METRIC DIM. AS REFERENCE		bel COMPONENTS FOR A CONNECTED PLANET
	DRAWN BY BL CHEN		DATE 07-28-08	FILE NAME 08261XX143-F_B.DWG	.X		UNIT : INCH [mm]	REV. : B	
				.XX		SCALE : N/A	SIZE : A4		
				.XXX	±0.004			PAGE : 5	