

ALS32 Series 85°C

RoHS
Compliant

- Case sizes and terminals for the Asian Market
- Long Life, 20000 hours at 85°C (Ur, Ir applied)
- High ripple current
- Excellent surge voltage capability
- Optimized designs available on request

APPLICATION	BASIC DESIGN
<ul style="list-style-type: none"> • Industrial and commercial applications. • Power supplies including switch mode. • UPS systems. • Variable speed drives. • Frequency Inverters. • Welding equipment. • Energy storage in pulse discharge applications. 	<p>The ALS32/33 series of screw terminal capacitors meets the requirements of the Asian market. This range offers high CV per unit volume coupled with high ripple currents and long life performance.</p>

SPECIFICATION																	
Standards	IEC 60384-4 Long Life Grade 40/85/56,																
Capacitance range	220 – 18000 µF																
Capacitance tolerance	±20%																
Rated voltage U_R	350–500 VDC																
Surge voltage U_s	1.10 x U _R Test Condition: ≤ 30s surge, 1000 cycles @ 85°C																
Surge voltage U_{ss} (Short duration)	<table border="1"> <thead> <tr> <th>U_R</th> <th>U_{ss}</th> </tr> </thead> <tbody> <tr><td>200</td><td>350</td></tr> <tr><td>250</td><td>400</td></tr> <tr><td>350</td><td>500</td></tr> <tr><td>400</td><td>520</td></tr> <tr><td>415</td><td>530</td></tr> <tr><td>450</td><td>550</td></tr> <tr><td>500</td><td>600</td></tr> </tbody> </table> Test Condition: ≤ 500ms surge, 100 cycles @ 20°C	U _R	U _{ss}	200	350	250	400	350	500	400	520	415	530	450	550	500	600
U _R	U _{ss}																
200	350																
250	400																
350	500																
400	520																
415	530																
450	550																
500	600																
Leakage current I_L	= 0.006 x C _R x U _R (µA) or 6mA whichever is the smaller. Note, C _R is in µF. Test Condition: U _R , 5mins., 20°C																
Operational life time +85°C, U_R, I_R	<table border="1"> <thead> <tr> <th>Can Diameter</th> <th>Life (hrs)</th> </tr> </thead> <tbody> <tr><td>36</td><td>11000</td></tr> <tr><td>51</td><td>18000</td></tr> <tr><td>63.5</td><td>19000</td></tr> <tr><td>77, 90</td><td>20000</td></tr> </tbody> </table> End of Life requirement: ΔC/C ≤ ±10% ESR ≤ 2 x initial ESR value I _L ≤ initial specified limit	Can Diameter	Life (hrs)	36	11000	51	18000	63.5	19000	77, 90	20000						
Can Diameter	Life (hrs)																
36	11000																
51	18000																
63.5	19000																
77, 90	20000																
+85°C, U_R	<table border="1"> <thead> <tr> <th>Can Diameter</th> <th>Life (hrs)</th> </tr> </thead> <tbody> <tr><td>36</td><td>22000</td></tr> <tr><td>51</td><td>36000</td></tr> <tr><td>63.5</td><td>38000</td></tr> <tr><td>77, 90</td><td>40000</td></tr> </tbody> </table>	Can Diameter	Life (hrs)	36	22000	51	36000	63.5	38000	77, 90	40000						
Can Diameter	Life (hrs)																
36	22000																
51	36000																
63.5	38000																
77, 90	40000																
Shelf Life	2000 hrs at 0V +85°C, or 30000 hrs at 0V +40°C																
Temperature range	-40 to +85°C (Operating) -55°C to +85°C (Storage)																

SPECIFICATION

Terminal style A

Terminal styles A (ø35mm), C

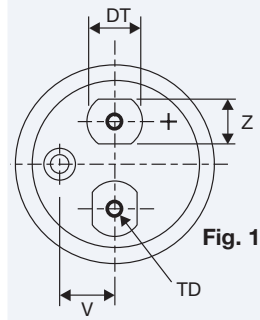

Fig. 1

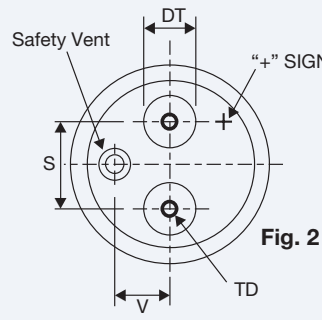
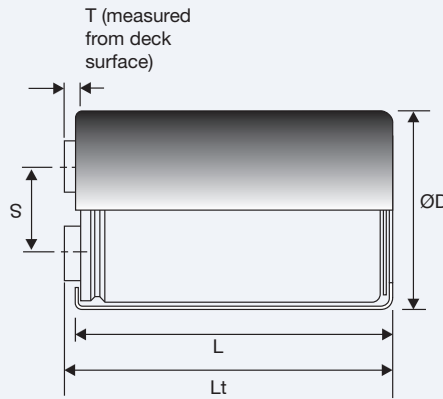
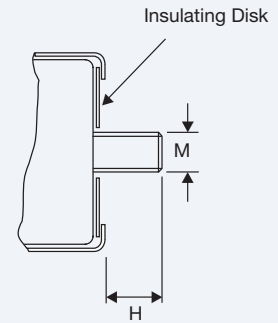

Fig. 2



**ALS32
Clamp Mounting**



**ALS33
Stud Mounting**

Case Polarity

Due to the presence of electrolyte in the capacitor the aluminium can and stud mounting will essentially be at the same polarity as the negative terminal. We recommend that the stud and can are insulated (see accessories for insulating nuts).

Terminations

Aluminium inserts M5 threads as standard, max. torque 2NM. M6 threaded inserts have a max. torque 4NM. Max. torque for stud mounting M8:4NM and M12:8NM.

Terminal options

Terminal Style	Case Diameter Availability	Thread	Height T mm ±0.8	Diameter DT mm ±0.5	Flats Z mm	Thread depth TD mm (min.)	Drawing
A	35mm only	M5	7.14	8	-	10	Fig.2
A	51, 63.5, 76 & 90mm	M5	5.5	13	10	10	Fig.1
C	63.5, 76 & 90mm	M6	5.5	13	-	10	Fig.2

Dimensions (mm)

CASE CODE	D unsleeved ±0.8	D sleeved ±0.8	L unsleeved ±1.6	L sleeved ±1.6	LT sleeved ±1	S ±0.5	T ±0.8	V	M THREAD	H ±1	MOUNTING CLIP	WEIGHT grams
D2C	34.9	35.3	54.0	55.1	61.5	12.8	7.14	8	M8	12	V3/H2/UTE2736	80
D2L	34.9	35.3	66.7	67.8	74.5	12.8	7.14	8	M8	12	V3/H2/UTE2736	95
D3C	34.9	35.3	79.4	80.5	87.5	12.8	7.14	8	M8	12	V3/H2/UTE2736	115
D3L	34.9	35.3	92.1	93.2	100.5	12.8	7.14	8	M8	12	V3/H2/UTE2736	130
D4C	34.9	35.3	104.8	105.9	112.5	12.8	7.14	8	M8	12	V3/H2/UTE2736	150
D4L	34.9	35.3	117.5	118.6	125.5	12.8	7.14	8	M8	12	V3/H2/UTE2736	165
D5C	34.9	35.3	130.2	131.3	138.5	12.8	7.14	8	M8	12	V3/H2/UTE2736	185
D5L	34.9	35.3	142.9	144.0	151.5	12.8	7.14	8	M8	12	V3/H2/UTE2736	205
K2C	50.8	51.2	54.0	55.1	60.0	22.2	5.5	13.7	M12	16	V4/UTE2737	165
K2L	50.8	51.2	66.7	67.8	73.0	22.2	5.5	13.7	M12	16	V4/UTE2737	200
K3C	50.8	51.2	79.4	80.5	86.0	22.2	5.5	13.7	M12	16	V4/UTE2737	240
K3L	50.8	51.2	92.1	93.2	98.0	22.2	5.5	13.7	M12	16	V4/UTE2737	275
K4C	50.8	51.2	104.8	105.9	111.0	22.2	5.5	13.7	M12	16	V4/UTE2737	315
K4L	50.8	51.2	117.5	118.6	124.0	22.2	5.5	13.7	M12	16	V4/UTE2737	350
K5C	50.8	51.2	130.2	131.3	136.0	22.2	5.5	13.7	M12	16	V4/UTE2737	385
K5L	50.8	51.2	142.9	144.0	149.0	22.2	5.5	13.7	M12	16	V4/UTE2737	425
L3C	63.5	63.9	79.4	80.5	84.0	28.5	5.5	15.8	M12	16	V8	370
L3L	63.5	63.9	92.1	93.2	97.0	28.5	5.5	15.8	M12	16	V8	430
L4C	63.5	63.9	104.8	105.9	110.0	28.5	5.5	15.8	M12	16	V8	485
L4L	63.5	63.9	117.5	118.6	123.0	28.5	5.5	15.8	M12	16	V8	545
L5C	63.5	63.9	130.2	131.3	135.0	28.5	5.5	15.8	M12	16	V8	600
L5L	63.5	63.9	142.9	144.0	148.0	28.5	5.5	15.8	M12	16	V8	660
N3L	76.2	76.6	92.1	93.2	97.0	31.8	5.5	19	M12	16	V11	615
N4C	76.2	76.6	104.8	105.9	110.0	31.8	5.5	19	M12	16	V11	700
N4L	76.2	76.6	117.5	118.6	123.0	31.8	5.5	19	M12	16	V11	780
N5C	76.2	76.6	130.2	131.3	135.0	31.8	5.5	19	M12	16	V11	865
N5L	76.2	76.6	142.9	144.0	148.0	31.8	5.5	19	M12	16	V11	950
N5R	76.2	76.6	149.2	150.4	154.0	31.8	5.5	19	M12	16	V11	990
N6L	76.2	76.6	168.3	169.4	173.0	31.8	5.5	19	M12	16	V11	1115
N7L	76.2	76.6	193.7	194.8	198.0	31.8	5.5	19	M12	16	V11	1280
N8L	76.2	76.6	219.1	220.2	224.0	31.8	5.5	19	M12	16	V11	1450
Q5R	88.9	90	149.2	150.4	154.0	31.8	5.5	25	M12	16	V90	1360
Q6L	88.9	90	168.3	169.4	173.0	31.8	5.5	25	M12	16	V90	1520
Q7L	88.9	90	193.7	194.8	198.0	31.8	5.5	25	M12	16	V90	1870
Q8L	88.9	90	219.1	220.2	224.0	31.8	5.5	25	M12	16	V90	2000

ARTICLE TABLE ALS32 (85°C)

Cap (μ F)	Nominal Case Size mm D x L	ESR max. ($m\Omega$) at 25°C		Ripple current(A) at 85°C		Part number
		120Hz	20kHz	120Hz	20kHz	
350 VDC (U_R)						
390	36 x 55	352	227	2.8	5.2	ALS32A391D2C350
470	36 x 80	291	187	3.5	6.7	ALS32A471D3C350
560	36 x 80	245	158	3.8	7.2	ALS32A561D3C350
680	36 x 80	203	132	4.1	7.7	ALS32A681D3C350
820	36 x 93	170	110	4.8	8.8	ALS32A821D3L350
1000	36 x 93	141	92	5.2	9.3	ALS32A102D3L350
1200	51 x 68	116	75	5.5	8.9	ALS32A122K2L350
1500	51 x 68	99	66	5.8	8.9	ALS32A152K2L350
1800	51 x 93	78	50	7.7	12.5	ALS32A182K3L350
2200	51 x 93	67	44	8.2	12.5	ALS32A222K3L350
2700	51 x 131	52	34	10.4	16.7	ALS32A272K5C350
3300	51 x 131	45	30	11.1	16.8	ALS32A332K5C350
3900	51 x 115	38	25	10.8	15.3	ALS32A392LJA350
5600	77 x 115	30	21	16.4	22.7	ALS32A562NJA350
6800	77 x 131	28	21	18.2	23.6	ALS32A682N5C350
8200	77 x 150	24	18	19.9	25.5	ALS32A822N5R350
10000	90 x 150	18	13	25.5	33.5	ALS32A103Q5R350
12000	90 x 150	16	12	25.9	32.4	ALS32A123Q5R350
15000	90 x 194	13	10	32.4	41.2	ALS32A153Q7L350
18000	90 x 220	12	9	38.5	47.6	ALS32A183Q8L350
400 VDC (U_R)						
330	36 x 55	351	207	2.6	5.4	ALS32A331D2C400
390	36 x 80	295	174	3.3	6.9	ALS32A391D3C400
470	36 x 80	246	146	3.6	7.5	ALS32A471D3C400
560	36 x 80	208	123	3.9	8.0	ALS32A561D3C400
680	36 x 93	182	112	4.5	8.7	ALS32A681D3L400
820	36 x 93	152	94	4.9	9.2	ALS32A821D3L400
1000	51 x 68	132	84	5.2	9.0	ALS32A102K2L400
1200	51 x 68	113	74	5.6	9.1	ALS32A122K2L400
1500	51 x 93	89	57	7.3	12.4	ALS32A152K3L400
1800	51 x 93	76	50	7.8	12.5	ALS32A182K3L400
2200	51 x 131	59	37	9.8	16.4	ALS32A222K5C400
2700	63.5 x 93	49	31	11.3	18.3	ALS32A272L3L400
3300	63.5 x 115	40	26	13.2	21.1	ALS32A332LJA400
3900	63.5 x 131	37	25	14.6	22.1	ALS32A392L5C400
4700	77 x 115	32	21	15.9	22.7	ALS32A472NJA400
5600	77 x 131	30	21	17.6	23.7	ALS32A562N5C400
6800	77 x 150	25	18	19.3	25.6	ALS32A682N5R400
8200	90 x 150	18	12	25.6	36.3	ALS32A822Q5R400
10000	90 x 150	16	11	26.5	35.6	ALS32A103Q5R400
12000	90 x 194	14	10	30.9	40.7	ALS32A123Q7L400
15000	90 x 220	12	9	37.4	47.7	ALS32A153Q8L400
450 VDC (U_R)						
270	36 x 55	383	215	2.5	5.4	ALS32A271D2C450
330	36 x 80	312	175	3.2	6.9	ALS32A331D3C450
390	36 x 80	265	149	3.4	7.4	ALS32A391D3C450
470	36 x 80	221	125	3.7	7.9	ALS32A471D3C450
560	36 x 93	196	115	4.2	8.6	ALS32A561D3L450
680	36 x 93	163	96	4.6	9.2	ALS32A681D3L450
820	51 x 68	142	86	5.0	9.0	ALS32A821K2L450
1000	51 x 68	120	75	5.3	9.1	ALS32A102K2L450
1200	51 x 93	94	56	6.9	12.3	ALS32A122K3L450
1500	51 x 115	75	45	8.1	14.5	ALS32A152KJA450
1800	51 x 131	63	38	9.3	16.3	ALS32A182K5C450

Mounting Style 2=plain or 3=stud 
Termination Style A,C 

ARTICLE TABLE ALS32 (85°C)

Cap (μ F)	Nominal Case Size mm D x L	ESR max. ($m\Omega$) at 25°C		Ripple current(A) at 85°C		Part number
		120Hz	20kHz	120Hz	20kHz	
450 VDC (U_R)						
2200	63.5 x 93	53	32	10.7	18.3	ALS32A222L3L450
2700	63.5 x 115	43	26	12.5	21.1	ALS32A272LJA450
3300	63.5 x 131	36	22	14.6	24.1	ALS32A332L5C450
3900	77 x 115	33	22	15.3	22.7	ALS32A392NJA450
4700	77 x 131	28	18	18.0	26.5	ALS32A472N5C450
5600	77 x 150	24	16	19.7	28.4	ALS32A562N5R450
6800	90 x 150	19	13	24.6	36.3	ALS32A682Q5R450
8200	90 x 150	17	12	25.7	35.8	ALS32A822Q5R450
10000	90 x 194	15	10	30.0	40.7	ALS32A103Q7L450
12000	90 x 220	14	10	35.7	46.9	ALS32A123Q8L450
500 VDC (U_R)						
220	36 x 55	602	427	2.3	4.1	ALS32A221D2C500
270	36 x 80	489	347	2.9	5.3	ALS32A271D3C500
330	36 x 80	402	285	3.2	5.8	ALS32A331D3C500
390	36 x 80	341	243	3.5	6.2	ALS32A391D3C500
470	36 x 93	303	221	3.9	6.8	ALS32A471D3L500
560	36 x 93	256	187	4.3	7.3	ALS32A561D3L500
680	51 x 68	219	162	4.6	7.4	ALS32A681K2L500
820	51 x 68	186	138	4.9	7.7	ALS32A821K2L500
1000	51 x 93	146	107	6.4	10.3	ALS32A102K3L500
1200	51 x 115	142	109	7.2	11.0	ALS32A122KJA500
1500	51 x 131	114	88	8.4	12.7	ALS32A152K5C500
1800	63.5 x 93	83	61	9.9	15.3	ALS32A182L3L500
2200	63.5 x 115	68	51	11.6	17.8	ALS32A222LJA500
2700	63.5 x 131	65	50	13.2	19.3	ALS32A272L5C500
3300	77 x 115	56	44	14.2	19.7	ALS32A332NJA500
3900	77 x 131	42	32	16.9	23.5	ALS32A392N5C500
4700	77 x 150	35	27	18.5	25.3	ALS32A472N5R500
5600	90 x 150	29	22	23.1	32.2	ALS32A562Q5R500
6800	90 x 150	25	19	24.1	32.3	ALS32A682Q5R500
8200	90 x 194	21	16	28.6	37.8	ALS32A822Q7L500
10000	90 x 220	18	14	34.4	44.3	ALS32A103Q8L500

Mounting Style 2=plain or 3=stud 
Termination Style A,C 

OPERATIONAL DATA

Operational Lifetime

Please see separate BHC application notes TD003 for calculating operational life expectancy under customer specific conditions.

RELIABILITY

The failure rate is derived from our periodic test results. The failure rate (λ_r) is therefore only given at test temperature for life tests. An estimation is also given at 40°C. The expected failure rate for this capacitor range is based on our periodic test results for capacitors with structural similarity. Failure rate is frequently quoted in FIT (Failures In Time) where 1 FIT = 1×10^{-9} failures per hour. Failure rates include both catastrophic and parametric failures

T_a	Failure rate per hour
85°C	250 FIT
40°C	12 FIT

MECHANICAL DATA

Mounting position

The capacitor can be mounted in any position so long as the safety vent can operate. It is possible for some electrolyte to be expelled. As this is a conducting liquid, suitable precautions should be instigated by the system designer to avoid secondary short circuits.

The capacitors are designed to be mounted in free air and are not suitable for submersion in liquid.

Vibration

10Hz to 55Hz at 0.75mm or 10g for 3x2hrs duration. Except 220mm long cans 10Hz to 55Hz at 0.35mm or 5g for 3x0.5hrs duration.

Insulating resistance

≥ 100 Mohms at 100V d.c., across insulating sleeve.

Voltage Proof

$\geq 2500V$ d.c., across insulating sleeve.

Safety vent

A safety vent for over pressure is featured on terminal deck. This is in the form of a rubber plug designed to relieve build up of internal pressure due to over stress or catastrophic failure.

Statements of suitability for certain applications are based on our knowledge of typical operating conditions for such applications, but are not intended to constitute – and we specifically disclaim – any warranty concerning suitability for a specific customer application or use. This Information is intended for use only by customers who have the requisite experience and capability to determine the correct products for their application. Any technical advice inferred from this Information or otherwise provided by us with reference to the use of our products is given gratis, and we assume no obligation or liability for the advice given or results obtained.