

PEH 532 105°C

RoHS
Compliant

- Snap-In
- Long Life Grade
- PCB Mounting
- Low ESR and ESL
- High ripple current

APPLICATION

Typical applications for PEH 532 would be SMPS, drives, welding equipment, UPS and other power electronic applications where high current ratings and compact size are important.

BASIC DESIGN

PEH 532 is a Long Life electrolytic capacitor designed to offer high ripple current capability and low mounting cost. The low ESR is a result of very low resistive paper/electrolyte system.

The low ESR together with the TDC thermal concept gives the PEH 532 a high ripple current capability.

SPECIFICATION

Standards	IEC 60384-4 Long Life Grade 40/105/56, in accordance with CECC 30 301-809
Capacitance range	68–27000 μ F
Capacitance tolerance	–20 to +20%
Rated voltage	35–450 VDC
Temperature range	–40 to +105°C
Leakage current, I_{RL} (μA)	$0.003 (\mu\text{A}) \times C_R (\mu\text{F}) \times U_R (\text{V})$
Operational life time	2000 hours at +105°C
Shelf life	4 years at 0 Volt and +40°C
Diameter range	22–35 mm

Pin configuration

Diameter range 22–35 mm: 2–3 pins

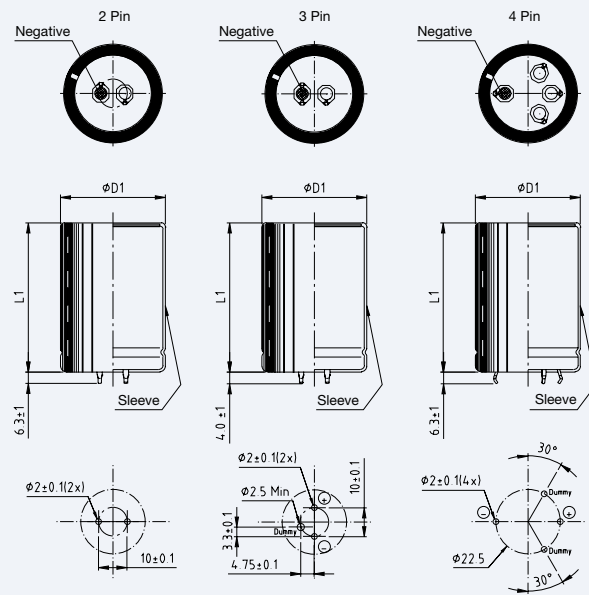

Dimensions table PEH 532 (mm)

D x L	Case code	D1 ±0.5	L1 ±1.0	Weight approx (g)
22 x 25	AB	22.5	26	13
22 x 30	AC	22.5	31	14
22 x 35	AD	22.5	36	15
22 x 40	AE	22.5	41	17
22 x 45	AF	22.5	46	19
22 x 50	AG	22.5	51	21
25 x 25	BB	25.5	26	19
25 x 30	BC	25.5	31	21
25 x 35	BD	25.5	36	24
25 x 40	BE	25.5	41	27
25 x 45	BF	25.5	46	30
25 x 50	BG	25.5	51	33
30 x 25	CB	30.5	26	24
30 x 30	CC	30.5	31	29
30 x 35	CD	30.5	36	34
30 x 40	DE	30.5	41	39
30 x 45	CF	30.5	46	45
30 x 50	CG	30.5	51	51
35 x 25	DB	35.5	26	32

D x L	Case code	D1 ±0.5	L1 ±1.0	Weight approx (g)
35 x 30	DC	35.5	31	40
35 x 35	DD	35.5	36	48
35 x 40	DE	35.5	41	56
35 x 45	DF	35.5	46	64
35 x 50	DG	35.5	51	72
35 x 55	DH	35.5	56	85

Pin Configuration

Description	2 pin	2 pin	3 pin	4 pin	4 pin
Pin length	6.3±1	4.0±1	4.0±1	6.3±1	4.0±1
Code	2	2S	3	4	4S
DIA. mm -0+1					
22	•	•	•		
25	•	•	•		
30	•	•	•		
35	•	•	•	•	•

ARTICLE TABLE PEH 532 (105°C)

C_R	D x L	Case code	I_{RAC}^* 105°C 100 Hz A	I_{RAC}^* 40°C 20 kHz A	ESR* 20°C 100 Hz mΩ	ESR* 20°C 100 kHz mΩ	Article code	Pin configuration
μF	mm							
35 VDC (U_R)								
3300	22 x 30	AC	1.9	5.1	110	93	PEH532JAC4330M2	
3900	22 x 30	AC	2.0	5.4	97	83	PEH532JAC4390M2	
4700	22 x 35	AD	2.3	6.2	80	67	PEH532JAD4470M2	
4700	25 x 30	BC	2.1	5.8	86	74	PEH532JBC4470M2	
5600	22 x 40	AE	2.6	7.1	67	56	PEH532JAE4560M2	
5600	25 x 30	BC	2.2	5.9	78	68	PEH532JBC4560M2	
6800	22 x 40	AE	2.8	7.5	58	50	PEH532JAE4680M2	
6800	25 x 35	BD	2.6	7.0	63	54	PEH532JBD4680M2	
6800	30 x 30	CC	3.1	8.4	54	46	PEH532JCC4680M2	
8200	22 x 50	AG	3.3	8.8	47	40	PEH532JAG4820M2	
8200	25 x 40	BE	2.9	8.0	52	45	PEH532JBE4820M2	
8200	30 x 30	CC	3.3	8.8	47	40	PEH532JCC4820M2	
10000	25 x 45	BF	3.3	9.0	43	38	PEH532JBF5100M2	
10000	30 x 35	CD	3.8	10.3	38	32	PEH532JCD5100M2	
10000	35 x 30	DC	3.6	9.6	42	36	PEH532JDC5100M2	
12000	25 x 50	BG	3.6	9.9	37	32	PEH532JBG5120M2	
12000	30 x 40	CE	4.4	11.7	32	27	PEH532JCE5120M2	
12000	35 x 30	DC	3.6	9.7	38	33	PEH532JDC5120M2	
15000	30 x 45	CF	5.0	13.3	26	22	PEH532JCF5150M2	
15000	35 x 35	DD	4.2	11.5	30	26	PEH532JDD5150M2	
18000	35 x 40	DE	4.9	13.2	25	22	PEH532JDE5180M2	
22000	35 x 45	DF	5.4	14.8	21	18	PEH532JDF5220M2	
27000	35 x 50	DG	5.9	16.3	18	16	PEH532JDG5270M2	
63 VDC (U_R)								
1200	22 x 25	AB	1.3	3.7	160	120	PEH532MAB4120M2	
1500	22 x 30	AC	1.6	4.4	120	90	PEH532MAC4150M2	
1800	22 x 30	AC	1.7	4.7	110	79	PEH532MAC4180M2	
2200	22 x 35	AD	2.0	5.5	88	64	PEH532MAD4220M2	
2200	25 x 30	BC	1.9	5.2	95	71	PEH532MBC4220M2	
2700	22 x 40	AE	2.3	6.3	72	52	PEH532MAE4270M2	
2700	25 x 35	BD	2.2	6.1	76	56	PEH532MBD4270M2	
3300	22 x 50	AG	2.7	7.4	58	42	PEH532MAG4330M2	
3300	25 x 40	BE	2.5	7.0	62	46	PEH532MBE4330M2	
3300	30 x 30	CC	2.7	7.4	58	42	PEH532MCC4330M2	
3900	25 x 45	BF	2.8	7.8	53	40	PEH532MBF4390M2	
3900	30 x 35	CD	3.1	8.5	48	35	PEH532MCD4390M2	
4700	25 x 50	BG	3.1	8.7	45	34	PEH532MBG4470M2	
4700	30 x 40	CE	3.6	9.7	40	29	PEH532MCE4470M2	
4700	35 x 30	DC	3.1	8.5	46	34	PEH532MDC4470M2	
5600	30 x 40	CE	3.8	10.3	35	26	PEH532MCE4560M2	
5600	35 x 35	DD	3.7	10.1	37	28	PEH532MDD4560M2	
6800	30 x 45	CF	4.3	11.7	29	22	PEH532MCF4680M2	
6800	35 x 40	DE	4.2	11.5	31	23	PEH532MDE4680M2	
8200	35 x 45	DF	4.7	13.0	26	19	PEH532MDF4820M2	
10000	35 x 50	DG	5.2	14.4	22	17	PEH532MDG5100M2	
100 VDC (U_R)								
560	22 x 25	AB	0.96	2.6	380	290	PEH532PAB3560M2	
680	22 x 30	AC	1.1	3.1	300	240	PEH532PAC3680M2	
680	25 x 25	BB	1.1	2.9	320	250	PEH532PBB3680M2	
820	22 x 35	AD	1.3	3.5	250	190	PEH532PAD3820M2	
820	25 x 30	BC	1.3	3.5	260	200	PEH532PBC3820M2	
1000	22 x 40	AE	1.5	4.0	210	160	PEH532PAE4100M2	
1000	25 x 30	BC	1.4	3.8	220	170	PEH532PBC4100M2	
1200	22 x 40	AE	1.6	4.4	170	140	PEH532PAE4120M2	
1200	25 x 35	BD	1.6	4.4	180	140	PEH532PBD4120M2	
1500	22 x 45	AF	1.9	5.0	140	110	PEH532PAF4150M2	
1500	25 x 40	BE	1.9	5.0	140	110	PEH532PBE4150M2	

* Maximum values

ARTICLE TABLE PEH 532 (105°C)

C_R	D x L	Case code	I_{RAC}^* 105°C 100 Hz A	I_{RAC}^* 40°C 20 kHz A	ESR* 20°C 100 Hz mΩ	ESR* 20°C 100 kHz mΩ	Article code	Pin configuration	
μF	mm								
100 VDC (U_R)									
1800	25 x 45	BF	2.1	5.7	120	95	PEH532PBF4180M2	↓	
1800	30 x 35	CD	2.2	6.0	120	90	PEH532PCD4180M2		
2200	25 x 50	BG	2.4	6.4	99	78	PEH532PBG4220M2		
2200	30 x 40	CE	2.6	6.9	95	73	PEH532PCE4220M2		
2200	35 x 30	DC	2.4	6.4	100	79	PEH532PDC4220M2		
2700	30 x 45	CF	2.9	7.8	78	60	PEH532PCF4270M2		
2700	35 x 35	DD	2.8	7.5	81	64	PEH532PDD4270M2		
3300	30 x 50	CG	3.3	8.9	64	50	PEH532PCG4330M2		
3300	35 x 40	DE	3.2	8.6	66	52	PEH532PDE4330M2		
3900	35 x 45	DF	3.6	9.7	56	44	PEH532PDF4390M2		
4700	35 x 50	DG	4.0	10.9	47	37	PEH532PDG4470M2		
200 VDC (U_R)									
270	22 x 30	AC	0.77	2.1	510	270	PEH532RAC3270M2		
270	25 x 25	BB	0.75	2.1	530	290	PEH532RBB3270M2		
330	22 x 35	AD	0.89	2.5	420	220	PEH532RAD3330M2		
330	25 x 30	BC	0.89	2.5	420	230	PEH532RBC3330M2		
390	22 x 35	AD	0.96	2.7	360	190	PEH532RAD3390M2		
390	25 x 30	BC	0.95	2.7	370	200	PEH532RBC3390M2		
470	22 x 40	AE	1.1	3.1	300	160	PEH532RAE3470M2		
470	25 x 35	BD	1.1	3.1	300	170	PEH532RBD3470M2		
470	30 x 30	CC	1.2	3.3	290	160	PEH532RCC3470M2		
560	22 x 45	AF	1.2	3.5	250	140	PEH532RAF3560M2		
560	25 x 40	BE	1.2	3.5	250	140	PEH532RBE3560M2		
680	22 x 50	AG	1.4	3.9	210	110	PEH532RAG3680M2		
680	25 x 45	BF	1.4	4.0	210	110	PEH532RBF3680M2		
680	30 x 35	CD	1.5	4.1	200	110	PEH532RCD3680M2		
820	25 x 50	BG	1.6	4.5	170	96	PEH532RBG3820M2		
820	30 x 35	CD	1.6	4.5	170	93	PEH532RCD3820M2		
1000	30 x 40	CE	1.8	5.2	140	76	PEH532RCE4100M2		
1000	35 x 35	DD	1.9	5.2	140	79	PEH532RDD4100M2		
1200	30 x 45	CF	2.1	5.8	120	64	PEH532RCF4120M2		
1200	35 x 40	DE	2.1	6.0	120	66	PEH532RDE4120M2		
1500	35 x 45	DF	2.5	6.9	96	53	PEH532RDF4150M2		
1800	35 x 50	DG	2.8	7.7	81	45	PEH532RDG4180M2		
2200	35 x 55	DH	3.1	8.7	67	38	PEH532RDH4220M2		
250 VDC (U_R)									
220	22 x 30	AC	0.73	2.1	520	260	PEH532SAC3220M2		
220	25 x 25	BB	0.71	2.0	540	270	PEH532SBB3220M2		
270	22 x 35	AD	0.85	2.4	420	210	PEH532SAD3270M2		
270	25 x 30	BC	0.85	2.4	430	220	PEH532SBC3270M2		
330	22 x 40	AE	0.97	2.7	350	170	PEH532SAE3330M2		
330	25 x 30	BC	0.92	2.6	360	180	PEH532SBC3330M2		
330	30 x 25	CB	0.98	2.7	350	170	PEH532SCB3330M2		
390	22 x 45	AF	1.1	3.1	290	140	PEH532SAF3390M2		
390	25 x 35	BD	1.1	3.0	300	150	PEH532SBD3390M2		
470	22 x 50	AG	1.2	3.5	250	120	PEH532SAG3470M2		
470	25 x 40	BE	1.2	3.4	250	130	PEH532SBE3470M2		
470	30 x 30	CC	1.2	3.4	250	120	PEH532SCC3470M2		
560	22 x 50	AG	1.3	3.8	210	110	PEH532SAG3560M2		
560	25 x 45	BF	1.4	3.8	210	110	PEH532SBF3560M2		
680	25 x 50	BG	1.5	4.3	180	90	PEH532SBG3680M2		
680	30 x 40	CE	1.6	4.5	170	84	PEH532SCE3680M2		
680	35 x 30	DC	1.5	4.3	180	91	PEH532SDC3680M2		
820	30 x 45	CF	1.8	5.1	140	70	PEH532SCF3820M2		
820	35 x 35	DD	1.8	5.0	150	75	PEH532SDD3820M2		
1000	30 x 50	CG	2.1	5.8	120	58	PEH532SCG4100M2		
1000	35 x 40	DE	2.1	5.8	120	61	PEH532SDE4100M2		
1200	35 x 45	DF	2.3	6.5	100	51	PEH532SDF4120M2		
1500	35 x 50	DG	2.7	7.5	81	42	PEH532SDG4150M2		

* Maximum values

ARTICLE TABLE PEH 532 (105°C)

C_R	D x L	Case code	I_{RAC}^* 105°C 100 Hz A	I_{RAC}^* 40°C 20 kHz A	ESR* 20°C 100 Hz mΩ	ESR* 20°C 100 kHz mΩ	Article code	Pin configuration
μF	mm							
350 VDC (U_R)								
82	22 x 25	AB	0.46	1.3	1600	980	PEH532UAB2820M2	
100	22 x 30	AC	0.53	1.5	1300	800	PEH532UAC3100M2	
150	22 x 35	AD	0.68	1.9	860	540	PEH532UAD3150M2	
150	25 x 30	BC	0.69	1.9	870	550	PEH532UBC3150M2	
180	22 x 40	AE	0.77	2.2	720	450	PEH532UAE3180M2	
220	22 x 45	AF	0.88	2.5	590	370	PEH532UAF3220M2	
220	25 x 35	BD	0.87	2.4	600	380	PEH532UBD3220M2	
220	30 x 30	CC	0.92	2.5	590	370	PEH532UCC3220M2	
270	22 x 50	AG	0.99	2.8	480	300	PEH532UAG3270M2	
270	25 x 40	BE	0.99	2.8	490	310	PEH532UBE3270M2	
330	25 x 50	BG	1.2	3.2	400	250	PEH532UBG3330M2	
330	30 x 40	CE	1.2	3.4	390	250	PEH532UCE3330M2	
330	35 x 30	DC	1.2	3.3	400	250	PEH532UDC3330M2	
390	25 x 50	BG	1.3	3.5	340	220	PEH532UBG3390M2	
390	30 x 40	CE	1.3	3.7	330	210	PEH532UCE3390M2	
470	30 x 45	CF	1.5	4.2	280	180	PEH532UCF3470M2	
470	35 x 35	DD	1.5	4.1	280	180	PEH532UDD3470M2	
560	30 x 50	CG	1.7	4.7	230	150	PEH532UCG3560M2	
560	35 x 40	DE	1.7	4.7	240	150	PEH532UDE3560M2	
680	35 x 45	DF	1.9	5.3	190	120	PEH532UDF3680M2	
400 VDC (U_R)								
82	22 x 30	AC	0.51	1.4	1300	810	PEH532VAC2820M2	
100	22 x 30	AC	0.56	1.6	1100	670	PEH532VAC3100M2	
100	25 x 25	BB	0.56	1.6	1100	690	PEH532VBB3100M2	
120	22 x 35	AD	0.64	1.8	920	560	PEH532VAD3120M2	
120	25 x 30	BC	0.65	1.8	930	570	PEH532VBC3120M2	
120	30 x 25	CB	0.68	1.9	920	560	PEH532VCB3120M2	
150	22 x 40	AE	0.75	2.1	740	450	PEH532VAE3150M2	
150	25 x 35	BD	0.76	2.1	740	450	PEH532VBD3150M2	
150	30 x 25	CB	0.76	2.1	740	460	PEH532VCB3150M2	
180	22 x 45	AF	0.84	2.4	620	380	PEH532VAF3180M2	
180	30 x 30	CC	0.88	2.4	620	380	PEH532VCC3180M2	
220	22 x 50	AG	0.95	2.7	510	310	PEH532VAG3220M2	
220	25 x 40	BE	0.95	2.7	510	320	PEH532VBE3220M2	
220	30 x 35	CD	1.0	2.8	500	310	PEH532VCD3220M2	
220	35 x 25	DB	0.97	2.7	510	320	PEH532VDB3220M2	
270	25 x 45	BF	1.1	3.0	420	260	PEH532VBF3270M2	
270	30 x 35	CD	1.1	3.1	410	250	PEH532VCD3270M2	
330	30 x 40	CE	1.3	3.6	340	210	PEH532VCE3330M2	
330	35 x 35	DD	1.3	3.7	340	210	PEH532VDD3330M2	
390	30 x 50	CG	1.5	4.1	280	170	PEH532VCG3390M2	
390	35 x 40	DE	1.5	4.1	290	180	PEH532VDE3390M2	
470	35 x 45	DF	1.7	4.7	240	150	PEH532VDF3470M2	
560	35 x 50	DG	1.9	5.3	200	120	PEH532VDG3560M2	
450 VDC (U_R)								
68	22 x 30	AC	0.50	1.4	1300	790	PEH532YAC2680M2	
68	25 x 25	BB	0.50	1.4	1400	800	PEH532YBB2680M2	
82	22 x 30	AC	0.55	1.5	1100	670	PEH532YAC2820M2	
82	25 x 25	BB	0.55	1.5	1100	680	PEH532YBB2820M2	
100	22 x 35	AD	0.63	1.8	910	540	PEH532YAD3100M2	
100	25 x 30	BC	0.64	1.8	920	540	PEH532YBC3100M2	
120	22 x 40	AE	0.72	2.0	760	450	PEH532YAE3120M2	
120	25 x 30	BC	0.70	1.9	780	470	PEH532YBC3120M2	
120	30 x 25	CB	0.73	2.0	770	460	PEH532YCB3120M2	
150	22 x 45	AF	0.83	2.3	620	370	PEH532YAF3150M2	
150	25 x 35	BD	0.82	2.3	620	370	PEH532YBD3150M2	
150	30 x 30	CC	0.86	2.4	620	360	PEH532YCC3150M2	

* Maximum values

ARTICLE TABLE PEH 532 (105°C)

C_R	D x L	Case code	I_{RAC}^* 105°C 100 Hz A	I_{RAC}^* 40°C 20 kHz A	ESR* 20°C 100 Hz mΩ	ESR* 20°C 100 kHz mΩ	Article code	Pin configuration
μF	mm							
450 VDC (U_R)								
180	22 x 50	AG	0.93	2.6	520	310	PEH532YAG3180M2	↓
180	25 x 40	BE	0.93	2.6	520	310	PEH532YBE3180M2	
180	30 x 30	CC	0.94	2.6	520	310	PEH532YCC3180M2	
220	25 x 45	BF	1.1	3.0	430	260	PEH532YBF3220M2	
220	30 x 35	CD	1.1	3.0	420	250	PEH532YCD3220M2	
220	35 x 30	DC	1.1	3.1	420	250	PEH532YDC3220M2	
270	30 x 40	CE	1.3	3.5	340	200	PEH532YCE3270M2	
270	35 x 35	DD	1.3	3.6	350	210	PEH532YDD3270M2	
330	30 x 50	CG	1.5	4.1	280	160	PEH532YCG3330M2	
330	35 x 40	DE	1.5	4.1	280	170	PEH532YDE3330M2	
390	35 x 40	DE	1.6	4.5	240	140	PEH532YDE3390M2	
470	35 x 50	DG	1.9	5.2	200	120	PEH532YDG3470M2	

* Maximum values

MECHANICAL DATA

The capacitor may be mounted in any position. The PEH 532 is supplied with PVC insulation sleeve, thickness 0.3 mm. Voltage proof of the insulation sleeve = 2.5 kVDC (1 min). The minus pole is marked on the case surface.

ORDERING INFORMATION

For further ordering information please see page 8.

Pos 1-20

P	E	H	5	3	2	M	A	B	4	1	2	0	M	2						
1	2	3	4	5	6	7	8	9	10	11	12	13	14	15	16	17	18	19	20	

Pos. 14: Capacitance tolerance M = -20 to +20%

Pos. 15: Pin configuration

Quantities and weights for PEH532

CASE CODE	AB	AC	AD	AE	AF	AG	BB	BC	BD	BE	BF	BG	CB	CC	CD	CE	CF
Weight approx (g)	13	14	15	17	19	21	19	21	24	27	30	33	24	29	34	39	45
Standard box quantity	200	100	100	100	100	100	200	100	100	100	100	100	200	100	100	100	100

Quantities and weights for PEH532

CASE CODE	CG	DB	DC	DD	DE	DF	DG	DH
Weight approx (g)	51	32	40	48	56	64	72	85
Standard box quantity	200	100	100	100	100	100	100	100

TYPICAL DATA PEH 532

Fig. 1

$C_T = C(f=100 \text{ Hz}, T_h) / C(f=100 \text{ Hz}, T_h = 20^\circ\text{C})$ vs T_h

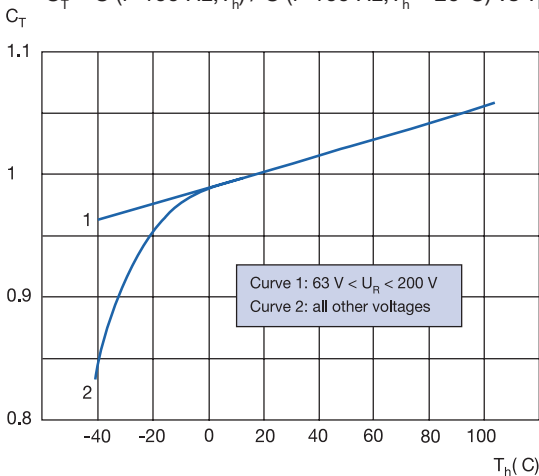

Fig. 2

$K_T = \text{ESR}(f, T_h) / \text{ESR}(f, T_h = 20^\circ\text{C})$ vs $T_h, U_R < 200 \text{ V}$

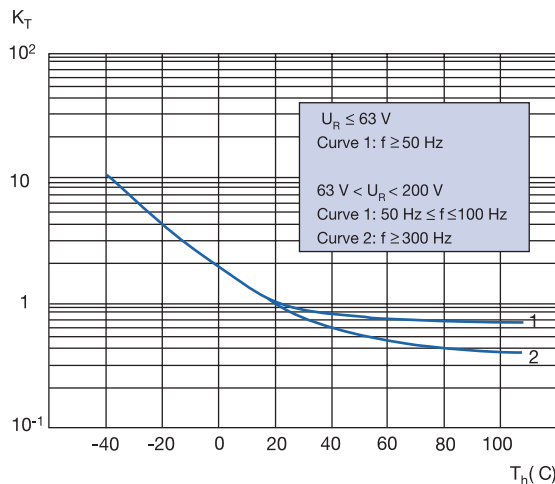

Fig. 4

$k_f = \text{ESR}(f, T_h = 20^\circ\text{C}) / \text{ESR}(f = 100 \text{ Hz}, T_h = 20^\circ\text{C})$ vs f

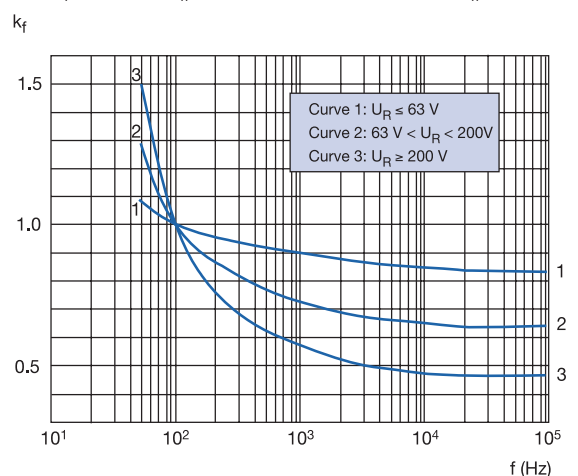
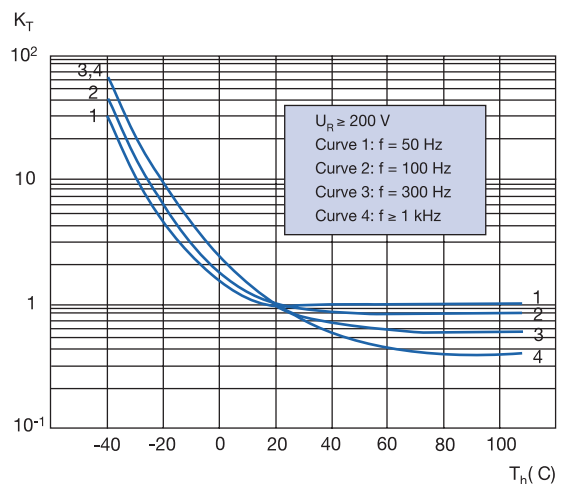

Fig. 5

$K_T = \text{ESR}(f, T_h) / \text{ESR}(f, T_h = 20^\circ\text{C})$ vs $T_h, U_R \geq 200 \text{ V}$



THERMAL RESISTANCE FOR DIFFERENT CASE SIZES, AS A FUNCTION OF CASE AIR SPEED V
At ambient temperature $T_a = 40^\circ\text{C}$

Case		Air speed v											
D x L		v=0,5m/s		v=1,0m/s		v=2,0m/s		v=3,0m/s		v=4,0m/s		v=5,0m/s	
mm		R_{thca}	R_{th}	R_{thca}	R_{th}	R_{thca}	R_{th}	R_{thca}	R_{th}	R_{thca}	R_{th}	R_{thca}	R_{th}
		$^\circ\text{C/W}$		$^\circ\text{C/W}$		$^\circ\text{C/W}$		$^\circ\text{C/W}$		$^\circ\text{C/W}$		$^\circ\text{C/W}$	
22 x 25	AB	24.3	25.1	19.1	20.0	14.8	15.7	13.2	14.1	11.4	12.3	10.3	11.1
22 x 30	AC	21.3	22.5	16.8	18.0	13.2	14.4	11.7	12.9	10.2	11.4	9.2	10.4
22 x 35	AD	19.1	20.5	15.1	16.6	11.9	13.4	10.7	12.1	9.4	10.8	8.5	9.9
22 x 40	AE	17.4	19.0	13.9	15.5	11.0	12.7	9.9	11.5	8.7	10.4	7.9	9.5
22 x 45	AF	16.1	17.6	12.9	14.4	10.4	11.8	9.3	10.8	8.3	9.7	7.5	9.0
22 x 50	AG	15.1	16.8	12.2	14.0	9.8	11.6	8.9	10.6	7.9	9.7	7.2	9.0
25 x 25	BB	21.9	22.8	17.2	18.1	13.4	14.3	11.8	12.6	10.2	11.1	9.2	10.0
25 x 30	BC	19.3	20.2	15.3	16.1	12.0	12.8	10.5	11.3	9.2	10.0	8.2	9.1
25 x 35	BD	17.2	18.2	13.7	14.7	10.8	11.8	9.6	10.6	8.4	9.4	7.6	8.6
25 x 40	BE	15.8	16.9	12.6	13.7	10.0	11.2	8.9	10.0	7.8	8.9	7.1	8.2
25 x 45	BF	14.7	16.2	11.8	13.3	9.4	10.9	8.4	9.9	7.4	8.9	6.8	8.3
25 x 50	BG	13.7	15.2	11.1	12.6	8.9	10.5	8.0	9.5	7.1	8.6	6.5	8.0
30 x 25	CB	18.9	19.5	14.9	15.5	11.7	12.3	10.0	10.6	8.7	9.3	7.8	8.4
30 x 30	CC	16.4	17.1	13.1	13.8	10.2	10.9	8.8	9.5	7.7	8.4	6.9	7.6
30 x 35	CD	14.8	15.6	11.8	12.6	9.3	10.1	8.0	8.9	7.0	7.9	6.3	7.2
30 x 40	CE	13.5	14.3	10.8	11.6	8.6	9.4	7.4	8.2	6.5	7.3	5.9	6.7
30 x 45	CF	12.5	13.3	10.0	10.9	8.0	8.9	7.0	7.8	6.2	7.0	5.6	6.5
30 x 50	CG	11.9	12.9	9.7	10.7	7.8	8.8	6.8	7.8	6.1	7.1	5.5	6.6
35 x 25	DB	16.5	17.0	13.1	13.6	10.5	11.0	8.6	9.1	7.5	8.0	6.7	7.2
35 x 30	DC	14.3	14.7	11.4	11.8	9.2	9.6	7.6	8.0	6.6	7.0	5.9	6.3
35 x 35	DD	12.9	13.4	10.3	10.8	8.3	8.8	6.9	7.4	6.0	6.5	5.4	5.9
35 x 40	DE	11.8	12.5	9.5	10.1	7.7	8.3	6.4	7.1	5.6	6.3	5.1	5.7
35 x 45	DF	10.9	11.6	8.8	9.5	7.1	7.9	6.0	6.7	5.3	6.0	4.8	5.5
35 x 50	DG	10.5	11.3	8.5	9.3	7.0	7.8	5.9	6.7	5.3	6.0	4.8	5.6
35 x 55	DH	9.6	10.3	7.8	8.5	6.4	7.1	5.4	6.1	4.8	5.5	4.4	5.1
35 x 60	DI	9.1	10.2	7.4	8.5	6.2	7.2	5.2	6.3	4.7	5.7	4.3	5.3
40 x 60	EI	8.2	9.0	6.7	7.6	5.5	6.3	4.6	5.5	4.1	5.0	3.8	4.7
40 x 70	EK	7.5	8.5	6.2	7.2	5.1	6.1	4.4	5.4	3.9	4.9	3.6	4.6
40 x 80	EM	7.0	8.3	5.9	7.2	4.9	6.2	4.2	5.5	3.8	5.1	3.5	4.8
40 x 100	EQ	6.4	8.2	5.4	7.2	4.6	6.3	4.1	5.8	3.7	5.4	3.4	5.2

(R_{thca} = Thermal resistance between case and ambient)

Statements of suitability for certain applications are based on our knowledge of typical operating conditions for such applications, but are not intended to constitute – and we specifically disclaim – any warranty concerning suitability for a specific customer application or use. This Information is intended for use only by customers who have the requisite experience and capability to determine the correct products for their application. Any technical advice inferred from this Information or otherwise provided by us with reference to the use of our products is given gratis, and we assume no obligation or liability for the advice given or results obtained.