

PEH 534 105°C

RoHS
Compliant

- Snap-In
- Long Life Grade
- PCB Mounting
- Low ESR and ESL
- High ripple current

APPLICATION

Typical applications for PEH 534 would be SMPS, drives, welding equipment, UPS and other power electronic applications where high current ratings and compact size are important.

BASIC DESIGN

PEH 534 is a Long Life electrolytic capacitor designed to offer high ripple current capability and low mounting cost. The low ESR is a result of very low resistive paper/electrolyte system.

The low ESR together with the TDC thermal concept gives the PEH 534 a high ripple current capability.

SPECIFICATION

Standards	IEC 60384-4 Long Life Grade 40/105/56, in accordance with CECC 30 301-809
Capacitance range	150–22000 μ F
Capacitance tolerance	–20 to +20%
Rated voltage	35–450 VDC
Temperature range	–40 to +105°C
Leakage current, I_{RL} (μA)	$0.003 (\mu\text{A}) \times C_R (\mu\text{F}) \times U_R (\text{V})$
Operational life time	4000 hours at +105°C
Shelf life	4 years at 0 Volt and +40°C
Diameter range	25–35 mm

Pin configuration	
Diameter range	25–35 mm: 2-3 pins

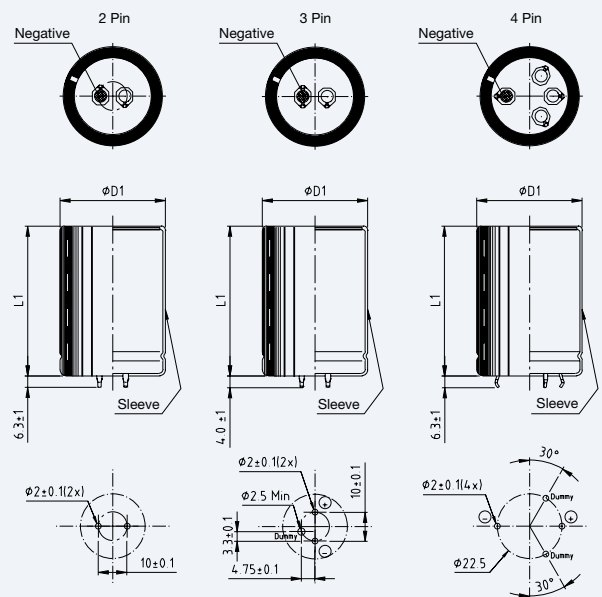

Dimensions table PEH 534 (mm)

D x L	Case code	D1 ±0.5	L1 ±1.0	Weight approx (g)
25 x 30	BC	25.5	31	21
25 x 35	BD	25.5	36	24
25 x 40	BE	25.5	41	27
25 x 45	BF	25.5	46	30
25 x 50	BG	25.5	51	33
30 x 25	CB	30.5	26	24
30 x 30	CC	30.5	31	29
30 x 35	CD	30.5	36	34
30 x 40	CE	30.5	41	39
30 x 45	CF	30.5	46	45
30 x 50	CG	30.5	51	51
35 x 25	DB	35.5	26	32
35 x 30	DC	35.5	31	40
35 x 35	DD	35.5	36	48
35 x 40	DE	35.5	41	56
35 x 45	DF	35.5	46	64
35 x 50	DG	35.5	51	72

Pin Configuration

Description	2 pin	2 pin	3 pin	4 pin	4 pin
Pin length	6.3±1	4.0±1	4.0±1	6.3±1	4.0±1
Code	2	2S	3	4	4S
DIA. mm -0+1					
25	•	•	•		
30	•	•	•		
35	•	•	•	•	•

ARTICLE TABLE PEH 534 (105°C)

C_R	D x L	Case code	I_{RAC}^* 105°C 100 Hz A	I_{RAC}^* 40°C 20 kHz A	ESR* 20°C 100 Hz mΩ	ESR* 20°C 100 kHz mΩ	Article code	Pin configuration
μF	mm							↓
35 VDC (U_R)								
5600	25 x 30	BC	2.3	7.6	54	43	PEH534JBC4560M2	
6800	25 x 35	BD	2.7	9.0	43	34	PEH534JBD4680M2	
6800	30 x 25	CB	2.9	9.8	40	31	PEH534JCB4680M2	
8200	25 x 40	BE	3.1	10.2	36	28	PEH534JBE4820M2	
8200	30 x 30	CC	3.5	12.1	31	23	PEH534JCC4820M2	
8200	35 x 25	DB	3.1	10.0	37	29	PEH534JDB4820M2	
10000	25 x 45	BF	3.5	11.3	31	24	PEH534JBF5100M2	
10000	30 x 35	CD	4.1	14.3	25	18	PEH534JCD5100M2	
15000	30 x 45	CF	5.3	17.8	17	13	PEH534JCF5150M2	
15000	35 x 35	DD	4.5	14.4	21	17	PEH534JDD5150M2	
22000	35 x 50	DG	6.2	20.1	14	11	PEH534JDG5220M2	
63 VDC (U_R)								
2200	25 x 30	BC	1.9	6.9	92	43	PEH534MBC4220M2	
3300	25 x 40	BE	2.5	9.3	61	34	PEH534MBE4330M2	
3300	30 x 30	CC	2.7	10.6	56	31	PEH534MCC4330M2	
4700	30 x 40	CE	3.6	14.0	39	28	PEH534MCE4470M2	
4700	35 x 30	DC	3.1	11.2	44	23	PEH534MDC4470M2	
5600	30 x 45	CF	4.0	15.6	33	29	PEH534MCF4560M2	
5600	35 x 35	DD	3.7	13.3	36	24	PEH534MDD4560M2	
6800	30 x 50	CG	4.5	17.1	28	18	PEH534MCG4680M2	
6800	35 x 40	DE	4.2	15.2	30	13	PEH534MDE4680M2	
8200	35 x 45	DF	4.7	16.8	26	17	PEH534MDF4820M2	
10000	35 x 50	DG	5.2	18.4	22	11	PEH534MDG5100M2	
100 VDC (U_R)								
1500	25 x 40	BE	1.9	7.0	140	110	PEH534PBE4150M2	
1500	30 x 30	CC	2.0	7.4	130	100	PEH534PCC4150M2	
2200	30 x 40	CE	2.6	9.8	91	70	PEH534PCE4220M2	
2200	35 x 30	DC	2.4	8.8	96	75	PEH534PDC4220M2	
3300	30 x 50	CG	3.3	12.4	62	48	PEH534PCG4330M2	
3300	35 x 40	DE	3.3	11.7	64	50	PEH534PDE4330M2	
3900	35 x 45	DF	3.6	13.1	54	43	PEH534PDF4390M2	
4700	35 x 50	DG	4.1	14.5	46	36	PEH534PDG4470M2	
200 VDC (U_R)								
470	25 x 35	BD	1.1	7.1	290	160	PEH534RBD3470M2	
560	25 x 40	BE	1.3	8.0	250	130	PEH534RBE3560M2	
560	30 x 30	CC	1.3	8.9	240	130	PEH534RCC3560M2	
680	25 x 45	BF	1.4	8.9	200	110	PEH534RBF3680M2	
680	30 x 35	CD	1.5	10.4	200	100	PEH534RCD3680M2	
680	35 x 30	DC	1.5	9.8	200	110	PEH534RDC3680M2	
820	30 x 40	CE	1.7	11.8	160	87	PEH534RCE3820M2	
820	35 x 30	DC	1.6	9.8	170	93	PEH534RDC3820M2	
1000	30 x 50	CG	2.0	13.9	130	71	PEH534RCG4100M2	
1000	35 x 35	DD	1.9	11.6	140	75	PEH534RDD4100M2	
1500	35 x 45	DF	2.5	14.7	93	51	PEH534RDF4150M2	
250 VDC (U_R)								
390	25 x 40	BE	1.1	7.9	290	140	PEH534SBE3390M2	
390	30 x 30	CC	1.1	8.7	280	140	PEH534SCC3390M2	
470	25 x 45	BF	1.3	8.8	240	120	PEH534SBF3470M2	
470	30 x 35	CD	1.3	10.1	240	110	PEH534SCD3470M2	
470	35 x 30	DC	1.3	9.6	240	120	PEH534SDC3470M2	
560	25 x 50	BG	1.4	9.6	200	100	PEH534SBG3560M2	

* Maximum values

ARTICLE TABLE PEH 534 (105°C)

C_R	D x L	Case code	I_{RAC}^* 105°C 100 Hz A	I_{RAC}^* 40°C 20 kHz A	ESR* 20°C 100 Hz mΩ	ESR* 20°C 100 kHz mΩ	Article code	Pin configuration
μF	mm							
250 VDC (U_R)								
560	30 x 40	CE	1.5	11.4	200	95	PEH534SCE3560M2	↓
680	30 x 45	CF	1.7	12.8	160	79	PEH534SCF3680M2	
680	35 x 35	DD	1.7	11.5	170	83	PEH534SDD3680M2	
820	30 x 50	CG	1.9	14.2	140	66	PEH534SCG3820M2	
820	35 x 40	DE	1.9	13.1	140	69	PEH534SDE3820M2	
1000	35 x 45	DF	2.2	14.6	110	57	PEH534SDF4100M2	
350 VDC (U_R)								
220	25 x 40	BE	0.91	5.8	560	350	PEH534UBE3220M2	
220	30 x 30	CC	0.93	6.0	550	340	PEH534UCC3220M2	
220	35 x 25	DB	0.94	5.8	560	350	PEH534UDB3220M2	
330	30 x 40	CE	1.2	8.0	370	230	PEH534UCE3330M2	
330	35 x 30	DC	1.2	7.4	370	230	PEH534UDC3330M2	
390	30 x 45	CF	1.4	9.0	310	190	PEH534UCF3390M2	
390	35 x 35	DD	1.4	8.6	320	200	PEH534UDD3390M2	
470	35 x 40	DE	1.6	9.7	260	160	PEH534UDE3470M2	
560	35 x 45	DF	1.8	10.9	220	140	PEH534UDF3560M2	
400 VDC (U_R)								
150	25 x 35	BD	0.78	5.1	680	410	PEH534VBD3150M2	
150	30 x 25	CB	0.78	5.2	680	400	PEH534VCB3150M2	
220	25 x 45	BF	1.0	6.5	470	280	PEH534VBF3220M2	
220	30 x 35	CD	1.0	7.1	460	270	PEH534VCD3220M2	
220	35 x 30	DC	1.1	7.0	460	280	PEH534VDC3220M2	
330	30 x 45	CF	1.4	9.2	310	180	PEH534VCF3330M2	
330	35 x 35	DD	1.4	8.7	310	190	PEH534VDD3330M2	
390	30 x 50	CG	1.5	10.2	260	160	PEH534VCG3390M2	
390	35 x 40	DE	1.5	9.8	260	160	PEH534VDE3390M2	
470	35 x 45	DF	1.8	11.1	220	130	PEH534VDF3470M2	
560	35 x 50	DG	2.0	12.3	180	110	PEH534VDG3560M2	
450 VDC (U_R)								
150	25 x 40	BE	0.88	5.8	570	330	PEH534YBE3150M2	
150	30 x 30	CC	0.89	6.1	560	330	PEH534YCC3150M2	
150	35 x 25	DB	0.90	5.9	570	330	PEH534YDB3150M2	
220	30 x 40	CE	1.2	8.1	380	220	PEH534YCE3220M2	
220	35 x 30	DC	1.2	7.5	390	230	PEH534YDC3220M2	
330	30 x 50	CG	1.5	10.3	260	150	PEH534YCG3330M2	
330	35 x 40	DE	1.5	9.9	260	150	PEH534YDE3330M2	
390	35 x 45	DF	1.7	11.3	220	130	PEH534YDF3390M2	
470	35 x 50	DG	1.9	12.4	180	110	PEH534YDG3470M2	

* Maximum values

MECHANICAL DATA

The capacitor may be mounted in any position. The PEH 534 is supplied with PVC insulation sleeve, thickness 0.3 mm. Voltage proof of the insulation sleeve = 2.5 kVDC (1 min). The minus pole is marked on the case surface.

ORDERING INFORMATION

For further ordering information please see page 8.

Pos 1-20

P	E	H	5	3	4	J	B	C	4	5	6	0	M	2					
1	2	3	4	5	6	7	8	9	10	11	12	13	14	15	16	17	18	19	20

Pos. 14: Capacitance tolerance M = -20 to +20%

Pos. 15: Pin configuration

Quantities and weights for PEH534

CASE CODE	BC	BD	BE	BF	BG	CB	CC	CD	CE	CF	CG	DB	DC	DD	DE	DF	DG
Weight approx (g)	21	24	27	30	33	24	29	34	39	45	51	32	40	48	56	64	72
Standard box quantity	100	100	100	100	100	200	100	100	100	100	100	200	100	100	100	100	100

TYPICAL DATA PEH 534

Fig. 1

$C_T = C(f=100 \text{ Hz}, T_h) / C(f=100 \text{ Hz}, T_h = 20^\circ\text{C})$ vs T_h

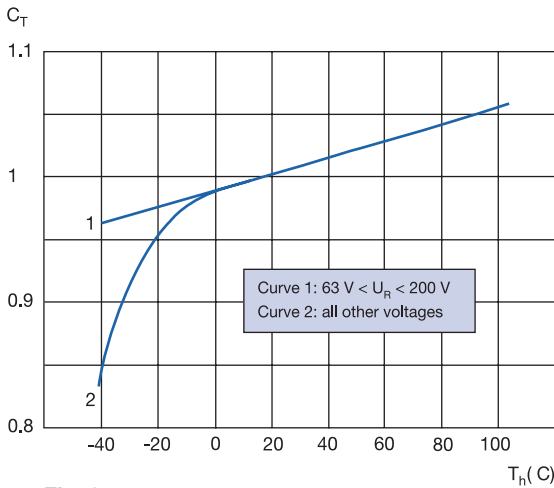

Fig. 4

$k_f = \text{ESR}(f, T_h = 20^\circ\text{C}) / \text{ESR}(f = 100 \text{ Hz}, T_h = 20^\circ\text{C})$ vs f

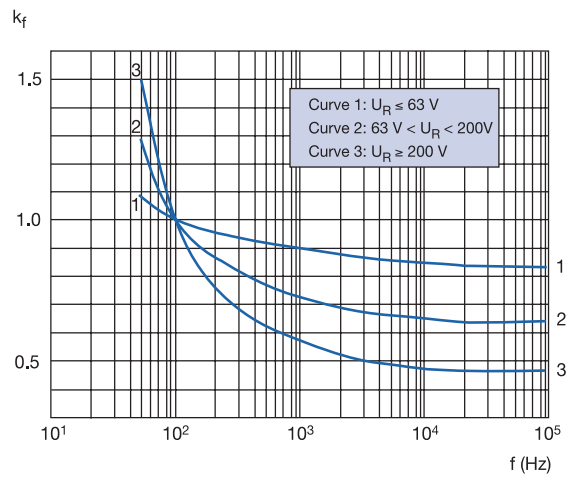

Fig. 2

$K_T = \text{ESR}(f, T_h) / \text{ESR}(f, T_h = 20^\circ\text{C})$ vs T_h , $U_R < 200 \text{ V}$

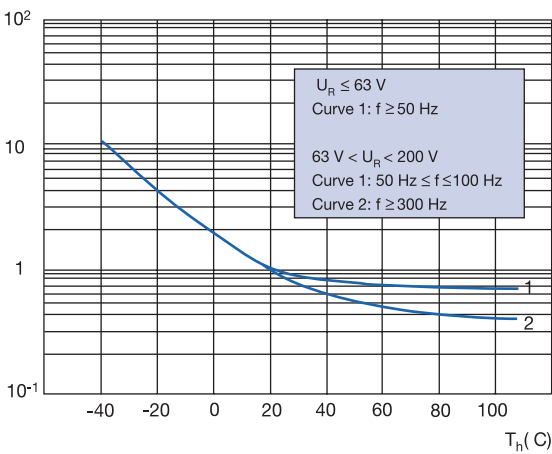
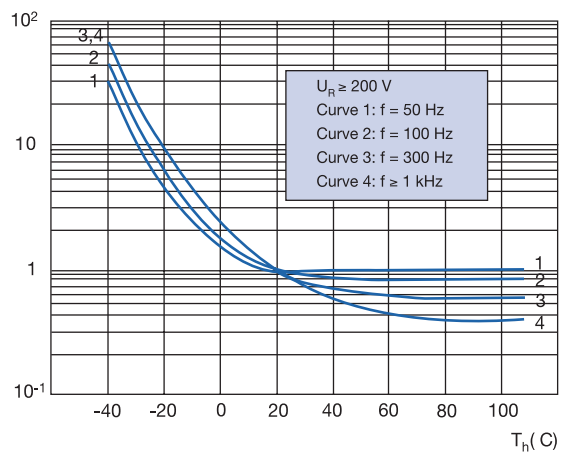

Fig. 5

$K_T = \text{ESR}(f, T_h) / \text{ESR}(f, T_h = 20^\circ\text{C})$ vs T_h , $U_R \geq 200 \text{ V}$



THERMAL RESISTANCE FOR DIFFERENT CASE SIZES, AS A FUNCTION OF CASE AIR SPEED V
At ambient temperature $T_a = 40^\circ\text{C}$

Case		Air speed v											
		v=0,5m/s		v=1,0m/s		v=2,0m/s		v=3,0m/s		v=4,0m/s		v=5,0m/s	
D x L	mm	R_{thca}	R_{th}	R_{thca}	R_{th}	R_{thca}	R_{th}	R_{thca}	R_{th}	R_{thca}	R_{th}	R_{thca}	R_{th}
		$^\circ\text{C/W}$		$^\circ\text{C/W}$		$^\circ\text{C/W}$		$^\circ\text{C/W}$		$^\circ\text{C/W}$		$^\circ\text{C/W}$	
22 x 25	AB	24.3	25.1	19.1	20.0	14.8	15.7	13.2	14.1	11.4	12.3	10.3	11.1
22 x 30	AC	21.3	22.5	16.8	18.0	13.2	14.4	11.7	12.9	10.2	11.4	9.2	10.4
22 x 35	AD	19.1	20.5	15.1	16.6	11.9	13.4	10.7	12.1	9.4	10.8	8.5	9.9
22 x 40	AE	17.4	19.0	13.9	15.5	11.0	12.7	9.9	11.5	8.7	10.4	7.9	9.5
22 x 45	AF	16.1	17.6	12.9	14.4	10.4	11.8	9.3	10.8	8.3	9.7	7.5	9.0
22 x 50	AG	15.1	16.8	12.2	14.0	9.8	11.6	8.9	10.6	7.9	9.7	7.2	9.0
25 x 25	BB	21.9	22.8	17.2	18.1	13.4	14.3	11.8	12.6	10.2	11.1	9.2	10.0
25 x 30	BC	19.3	20.2	15.3	16.1	12.0	12.8	10.5	11.3	9.2	10.0	8.2	9.1
25 x 35	BD	17.2	18.2	13.7	14.7	10.8	11.8	9.6	10.6	8.4	9.4	7.6	8.6
25 x 40	BE	15.8	16.9	12.6	13.7	10.0	11.2	8.9	10.0	7.8	8.9	7.1	8.2
25 x 45	BF	14.7	16.2	11.8	13.3	9.4	10.9	8.4	9.9	7.4	8.9	6.8	8.3
25 x 50	BG	13.7	15.2	11.1	12.6	8.9	10.5	8.0	9.5	7.1	8.6	6.5	8.0
30 x 25	CB	18.9	19.5	14.9	15.5	11.7	12.3	10.0	10.6	8.7	9.3	7.8	8.4
30 x 30	CC	16.4	17.1	13.1	13.8	10.2	10.9	8.8	9.5	7.7	8.4	6.9	7.6
30 x 35	CD	14.8	15.6	11.8	12.6	9.3	10.1	8.0	8.9	7.0	7.9	6.3	7.2
30 x 40	CE	13.5	14.3	10.8	11.6	8.6	9.4	7.4	8.2	6.5	7.3	5.9	6.7
30 x 45	CF	12.5	13.3	10.0	10.9	8.0	8.9	7.0	7.8	6.2	7.0	5.6	6.5
30 x 50	CG	11.9	12.9	9.7	10.7	7.8	8.8	6.8	7.8	6.1	7.1	5.5	6.6
35 x 25	DB	16.5	17.0	13.1	13.6	10.5	11.0	8.6	9.1	7.5	8.0	6.7	7.2
35 x 30	DC	14.3	14.7	11.4	11.8	9.2	9.6	7.6	8.0	6.6	7.0	5.9	6.3
35 x 35	DD	12.9	13.4	10.3	10.8	8.3	8.8	6.9	7.4	6.0	6.5	5.4	5.9
35 x 40	DE	11.8	12.5	9.5	10.1	7.7	8.3	6.4	7.1	5.6	6.3	5.1	5.7
35 x 45	DF	10.9	11.6	8.8	9.5	7.1	7.9	6.0	6.7	5.3	6.0	4.8	5.5
35 x 50	DG	10.5	11.3	8.5	9.3	7.0	7.8	5.9	6.7	5.3	6.0	4.8	5.6
35 x 55	DH	9.6	10.3	7.8	8.5	6.4	7.1	5.4	6.1	4.8	5.5	4.4	5.1
35 x 60	DI	9.1	10.2	7.4	8.5	6.2	7.2	5.2	6.3	4.7	5.7	4.3	5.3
40 x 60	EI	8.2	9.0	6.7	7.6	5.5	6.3	4.6	5.5	4.1	5.0	3.8	4.7
40 x 70	EK	7.5	8.5	6.2	7.2	5.1	6.1	4.4	5.4	3.9	4.9	3.6	4.6
40 x 80	EM	7.0	8.3	5.9	7.2	4.9	6.2	4.2	5.5	3.8	5.1	3.5	4.8
40 x 100	EQ	6.4	8.2	5.4	7.2	4.6	6.3	4.1	5.8	3.7	5.4	3.4	5.2

(R_{thca} = Thermal resistance between case and ambient)

Statements of suitability for certain applications are based on our knowledge of typical operating conditions for such applications, but are not intended to constitute – and we specifically disclaim – any warranty concerning suitability for a specific customer application or use. This Information is intended for use only by customers who have the requisite experience and capability to determine the correct products for their application. Any technical advice inferred from this Information or otherwise provided by us with reference to the use of our products is given gratis, and we assume no obligation or liability for the advice given or results obtained.