

PEH 536 105°C

RoHS
Compliant

- Snap-In
- Ultra Long Life Grade
- PCB Mounting
- Low ESR and ESL
- High ripple current

APPLICATION

Typical applications for PEH 536 would be SMPS, drives, welding equipment, UPS and other power electronic applications where high current ratings and compact size are important.

BASIC DESIGN

PEH 536 is a Long Life electrolytic capacitor designed to offer high ripple current capability and low mounting cost. The low ESR is a result of very low resistive paper/electrolyte system.

The low ESR together with the TDC thermal concept gives the PEH 536 a high ripple current capability.

SPECIFICATION

Standards	IEC 60384-4 Long Life Grade 40/105/56, in accordance with CECC 30 301-809
Capacitance range	47-18000 μ F
Capacitance tolerance	-20 to +20%
Rated voltage	35-450 VDC
Temperature range	-40 to +105°C
Leakage current, I_{RL} (μA)	$0.003 (\mu\text{A}) \times C_R (\mu\text{F}) \times U_R (\text{V})$
Operational life time	6000 hours at +105°C
Shelf life	4 years at 0 Volt and +40°C
Diameter range	22-40 mm

Pin configuration	
Diameter range	22-35 mm: 2-3 pins 40 mm: 4 pins

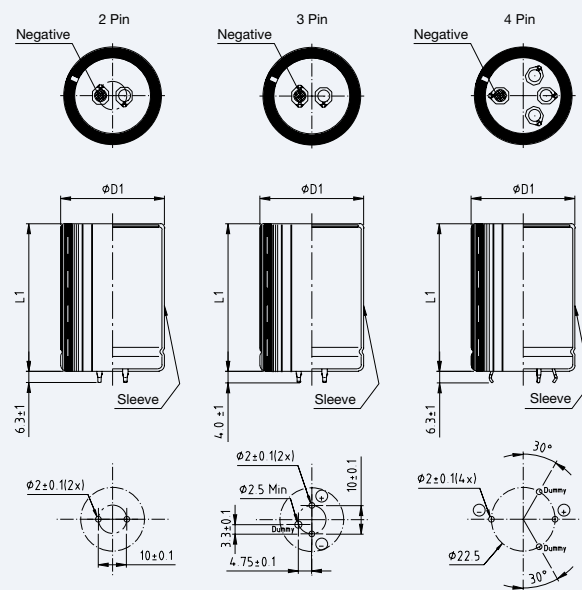

Dimensions table PEH 536 (mm)

D x L	Case code	D1 ±0.5	L1 ±1.0	Weight approx (g)
22 x 30	AC	22.5	31	14
22 x 35	AD	22.5	36	15
22 x 40	AE	22.5	41	17
22 x 45	AF	22.5	46	19
22 x 50	AG	22.5	51	21
25 x 25	BB	25.5	26	19
25 x 30	BC	25.5	31	21
25 x 35	BD	25.5	36	24
25 x 40	BE	25.5	41	27
25 x 45	BF	25.5	46	30
25 x 50	BG	25.5	51	33
30 x 25	CB	30.5	26	24
30 x 30	CC	30.5	31	29
30 x 35	CD	30.5	36	34
30 x 40	CE	30.5	41	39
30 x 45	CF	30.5	46	45
30 x 50	CG	30.5	51	51
35 x 25	DB	35.5	26	32
35 x 30	DC	35.5	31	40
35 x 35	DD	35.5	36	48
35 x 40	DE	35.5	41	56
35 x 45	DF	35.5	46	64
35 x 50	DG	35.5	51	72
35 x 55	DH	35.5	56	85

D x L	Case code	D1 ±0.5	L1 ±1.0	Weight approx (g)
35 x 60	DI	35.5	61	88
40 x 60	EI	40.5	61	115
40 x 70	EK	40.5	71	135
40 x 80	EM	40.5	81	155
40 x 100	EQ	40.5	101	175

Pin Configuration

Description	2 pin	2 pin	3 pin	4 pin	4 pin
Pin length	6.3±1	4.0±1	4.0±1	6.3±1	4.0±1
Code	2	2S	3	4	4S
DIA. mm -0+1					
22	•	•	•		
25	•	•	•		
30	•	•	•		
35	•	•	•	•	•
40	•	•	•	•	•

ARTICLE TABLE PEH 536 (105°C)

C_R	D x L	Case code	I_{RAC}^* 105°C 100 Hz A	I_{RAC}^* 40°C 20 kHz A	ESR* 20°C 100 Hz mΩ	ESR* 20°C 100 kHz mΩ	Article code	Pin configuration
μF	mm							
35 VDC (U_R)								
3900	22 x 35	AD	2.4	9.0	54	39	PEH536JAD4390M2	
3900	25 x 30	BC	2.2	7.8	60	45	PEH536JBC4390M2	
4700	22 x 40	AE	2.8	0.2	45	33	PEH536JAE4470M2	
5600	25 x 35	BD	2.7	9.1	44	34	PEH536JBD4560M2	
5600	30 x 30	CC	2.4	7.8	53	43	PEH536JCC4560M2	
5600	35 x 25	DB	2.0	5.9	78	68	PEH536JDB4560M2	
6800	25 x 40	BE	3.1	10.4	37	28	PEH536JBE4680M2	
6800	30 x 35	CD	2.9	9.4	42	33	PEH536JCD4680M2	
8200	25 x 45	BF	3.4	11.6	31	24	PEH536JBF4820M2	
8200	30 x 35	CD	2.8	8.9	42	35	PEH536JCD4820M2	
8200	35 x 30	DC	3.7	12.6	30	23	PEH536JDC4820M2	
10000	25 x 50	BG	3.7	12.3	27	21	PEH536JBG5100M2	
10000	30 x 40	CE	4.6	16.6	22	16	PEH536JCE5100M2	
12000	30 x 45	CF	5.1	18.1	19	14	PEH536JCF5120M2	
12000	35 x 35	DD	4.4	14.5	22	17	PEH536JDD5120M2	
15000	35 x 40	DE	5.0	16.5	18	14	PEH536JDE5150M2	
18000	35 x 50	DG	6.1	20.4	14	11	PEH536JDG5180M2	
63 VDC (U_R)								
1800	22 x 35	AD	1.9	7.3	100	74	PEH536MAD4180M2	
1800	25 x 30	BC	2.0	8.2	97	68	PEH536MBC4180M2	
1800	30 x 25	CB	2.0	7.8	100	72	PEH536MCB4180M2	
2200	25 x 35	BD	2.1	7.8	88	65	PEH536MBD4220M2	
2200	30 x 30	CC	2.3	9.4	81	57	PEH536MCC4220M2	
2200	35 x 25	DB	2.3	8.6	86	62	PEH536MDB4220M2	
2700	22 x 50	AG	2.5	9.8	68	49	PEH536MAG4270M2	
2700	25 x 40	BE	2.4	8.9	73	53	PEH536MBE4270M2	
2700	30 x 35	CD	2.7	10.9	66	46	PEH536MCD4270M2	
3300	25 x 50	BG	2.8	10.7	58	43	PEH536MBG4330M2	
3300	30 x 35	CD	2.9	11.5	55	40	PEH536MCD4330M2	
3900	30 x 40	CE	3.3	13.0	47	34	PEH536MCE4390M2	
3900	35 x 30	DC	3.0	10.9	52	38	PEH536MDC4390M2	
4700	30 x 45	CF	3.7	14.6	39	28	PEH536MCF4470M2	
4700	35 x 35	DD	3.5	12.9	42	31	PEH536MDD4470M2	
6800	35 x 45	DF	4.5	16.4	30	22	PEH536MDF4680M2	
8200	35 x 50	DG	5.0	17.9	25	19	PEH536MDG4820M2	
100 VDC (U_R)								
560	22 x 30	AC	1.1	4.3	320	240	PEH536PAC3560M2	
560	25 x 25	BB	1.1	4.0	330	250	PEH536PBB3560M2	
680	22 x 35	AD	1.2	5.0	260	190	PEH536PAD3680M2	
680	25 x 30	BC	1.2	4.8	270	200	PEH536PBC3680M2	
820	22 x 40	AE	1.4	5.6	220	160	PEH536PAE3820M2	
820	25 x 30	BC	1.3	5.1	230	170	PEH536PBC3820M2	
820	30 x 25	CB	1.4	5.6	220	160	PEH536PCB3820M2	
1000	25 x 35	BD	1.6	6.0	180	140	PEH536PBD4100M2	
1000	30 x 30	CC	1.7	6.6	180	130	PEH536PCC4100M2	
1200	25 x 40	BE	1.8	6.8	150	120	PEH536PBE4120M2	
1200	30 x 35	CD	1.9	7.7	150	110	PEH536PCD4120M2	
1500	25 x 50	BG	2.1	8.1	120	92	PEH536PBG4150M2	
1500	30 x 40	CE	2.2	8.9	120	88	PEH536PCE4150M2	
2200	30 x 50	CG	2.8	11.2	81	61	PEH536PCG4220M2	
2200	35 x 40	DE	2.8	10.9	83	62	PEH536PDE4220M2	
2700	35 x 45	DF	3.2	12.3	68	51	PEH536PDF4270M2	
3300	35 x 50	DG	3.6	13.8	56	43	PEH536PDG4330M2	
4700	35 x 55	DH	4.3	15.8	42	32	PEH536PDH4470M2	

* Maximum values

ARTICLE TABLE PEH 536 (105°C)

C_R	D x L	Case code	I_{RAC}^* 105°C 100 Hz A	I_{RAC}^* 40°C 20 kHz A	ESR* 20°C 100 Hz mΩ	ESR* 20°C 100 kHz mΩ	Article code	Pin configuration
μF	mm							
200 VDC (U_R)								
220	22 x 30	AC	0.71	5.4	550	270	PEH536RAC3220M2	
270	25 x 30	BC	0.82	5.9	460	220	PEH536RBC3270M2	
330	22 x 40	AE	0.93	7.2	370	180	PEH536RAE3330M2	
330	25 x 35	BD	0.95	6.9	370	190	PEH536RBD3330M2	
470	22 x 50	AG	1.2	8.8	260	130	PEH536RAG3470M2	
470	25 x 40	BE	1.2	8.1	270	130	PEH536RBE3470M2	
560	25 x 45	BF	1.3	9.1	220	110	PEH536RBF3560M2	
560	30 x 35	CD	1.4	10.4	220	110	PEH536RCD3560M2	
680	25 x 50	BG	1.5	10.0	180	93	PEH536RBG3680M2	
680	30 x 40	CE	1.6	11.8	180	88	PEH536RCE3680M2	
680	35 x 35	DD	1.6	11.5	180	90	PEH536RDD3680M2	
820	30 x 45	CF	1.8	13.3	150	73	PEH536RCF3820M2	
820	35 x 35	DD	1.8	11.8	150	77	PEH536RDD3820M2	
1000	30 x 50	CG	2.0	14.8	120	61	PEH536RCG4100M2	
1000	35 x 40	DE	2.0	13.5	130	63	PEH536RDE4100M2	
1200	35 x 50	DG	2.3	16.2	100	52	PEH536RDG4120M2	
250 VDC (U_R)								
150	22 x 30	AC	0.62	5.3	660	280	PEH536SAC3150M2	
220	22 x 40	AE	0.81	7.0	450	190	PEH536SAE3220M2	
220	25 x 30	BC	0.79	6.0	460	200	PEH536SBC3220M2	
270	25 x 35	BD	0.91	7.1	370	160	PEH536SBD3270M2	
330	25 x 40	BE	1.0	8.1	300	130	PEH536SBE3330M2	
330	30 x 30	CC	1.1	8.8	300	130	PEH536SCC3330M2	
390	25 x 45	BF	1.2	9.0	260	110	PEH536SBF3390M2	
470	25 x 50	BG	1.3	9.9	210	96	PEH536SBG3470M2	
470	30 x 40	CE	1.4	11.7	210	91	PEH536SCE3470M2	
560	30 x 45	CF	1.6	13.1	180	76	PEH536SCF3560M2	
680	30 x 50	CG	1.8	14.5	150	63	PEH536SCG3680M2	
680	35 x 40	DE	1.8	13.4	150	66	PEH536SDE3680M2	
820	35 x 45	DF	2.0	15.0	120	55	PEH536SDF3820M2	
1000	35 x 50	DG	2.3	16.5	100	46	PEH536SDG4100M2	
350 VDC (U_R)								
100	22 x 30	AC	0.56	3.9	1000	600	PEH536UAC3100M2	
100	25 x 25	BB	0.56	3.7	1100	620	PEH536UBB3100M2	
120	22 x 35	AD	0.64	4.5	870	500	PEH536UAD3120M2	
150	22 x 40	AE	0.74	5.2	700	400	PEH536UAE3150M2	
150	25 x 30	BC	0.72	4.7	710	410	PEH536UBC3150M2	
180	22 x 45	AF	0.84	5.8	580	340	PEH536UAF3180M2	
220	22 x 50	AG	0.95	6.5	480	280	PEH536UAG3220M2	
220	25 x 40	BE	0.95	6.2	480	280	PEH536UBE3220M2	
270	25 x 50	BG	1.1	7.4	390	230	PEH536UBG3270M2	
270	30 x 40	CE	1.2	8.1	390	220	PEH536UCE3270M2	
330	30 x 45	CF	1.3	9.2	320	180	PEH536UCF3330M2	
330	35 x 35	DD	1.3	8.7	320	190	PEH536UDD3330M2	
470	35 x 40	DE	1.6	10.5	230	130	PEH536UDE3470M2	
560	35 x 45	DF	1.8	11.8	190	110	PEH536UDF3560M2	
560	35 x 50	DG	1.9	12.4	190	110	PEH536UDG3560M2	
680	35 x 60	DI	2.2	14.3	160	91	PEH536UDI3680M2	
1000	40 x 80	EM	2.9	18.5	110	63	PEH536UEM4100M4	

* Maximum values

ARTICLE TABLE PEH 536 (105°C)

C_R	D x L	Case code	I_{RAC}^* 105°C 100 Hz A	I_{RAC}^* 40°C 20 kHz A	ESR* 20°C 100 Hz mΩ	ESR* 20°C 100 kHz mΩ	Article code	Pin configuration
μF	mm							
400 VDC (U_R)								
68	22 x 30	AC	0.50	3.6	1300	710	PEH536VAC2680M2	
68	25 x 25	BB	0.50	3.5	1300	720	PEH536VBB2680M2	
82	22 x 35	AD	0.57	4.2	1100	590	PEH536VAD2820M2	
100	22 x 35	AD	0.63	4.6	870	480	PEH536VAD3100M2	
100	25 x 30	BC	0.64	4.4	880	490	PEH536VBC3100M2	
120	22 x 40	AE	0.71	5.2	720	400	PEH536VAE3120M2	
150	22 x 50	AG	0.83	6.1	580	320	PEH536VAG3150M2	
150	25 x 40	BE	0.84	5.9	580	330	PEH536VBE3150M2	
150	30 x 30	CC	0.86	6.2	580	320	PEH536VCC3150M2	
180	30 x 35	CD	0.98	7.1	480	270	PEH536VCD3180M2	
180	35 x 30	DC	1.0	7.1	480	270	PEH536VDC3180M2	
220	25 x 50	BG	1.1	7.4	400	220	PEH536VBG3220M2	
220	30 x 40	CE	1.1	8.2	390	220	PEH536VCE3220M2	
270	30 x 45	CF	1.3	9.3	320	180	PEH536VCF3270M2	
330	30 x 50	CG	1.5	10.5	260	150	PEH536VCG3330M2	
330	35 x 40	DE	1.5	10.1	270	150	PEH536VDE3330M2	
390	35 x 45	DF	1.7	11.3	230	130	PEH536VDF3390M2	
470	35 x 50	DG	1.9	12.6	190	110	PEH536VDG3470M2	
560	35 x 55	DH	2.1	13.9	160	89	PEH536VDH3560M2	
680	40 x 60	EI	2.5	15.9	130	74	PEH536VEI3680M4	
1000	40 x 80	EM	3.1	19.7	90	51	PEH536VEM4100M4	
1500	40 x 100	EQ	3.9	22.9	61	35	PEH536VEQ4150M4	
450 VDC (U_R)								
47	22 x 30	AC	0.44	3.4	1500	840	PEH536YAC2470M2	
68	22 x 40	AE	0.57	4.4	1100	580	PEH536YAE2680M2	
68	25 x 30	BC	0.57	4.1	1100	580	PEH536YBC2680M2	
100	22 x 45	AF	0.72	5.4	720	390	PEH536YAF3100M2	
100	25 x 35	BD	0.72	5.2	730	400	PEH536YBD3100M2	
120	22 x 50	AG	0.81	6.0	600	330	PEH536YAG3120M2	
150	25 x 45	BF	0.94	6.7	490	270	PEH536YBF3150M2	
150	30 x 35	CD	0.97	7.2	480	260	PEH536YCD3150M2	
180	30 x 40	CE	1.1	8.2	400	220	PEH536YCE3180M2	
220	30 x 45	CF	1.3	9.3	330	180	PEH536YCF3220M2	
220	35 x 40	DE	1.3	9.4	330	180	PEH536YDE3220M2	
270	30 x 50	CG	1.4	10.4	270	150	PEH536YCG3270M2	
270	35 x 45	DF	1.5	10.7	270	150	PEH536YDF3270M2	
330	35 x 50	DG	1.7	11.9	220	120	PEH536YDG3330M2	
390	35 x 55	DH	1.9	13.2	190	100	PEH536YDH3390M2	
470	35 x 60	DI	2.1	14.5	160	86	PEH536YDI3470M2	
560	40 x 60	EI	2.4	16.0	130	73	PEH536YEI3560M4	
680	40 x 70	EK	2.7	17.9	110	61	PEH536YEK3680M4	
1000	40 x 100	EQ	3.4	21.9	75	42	PEH536YEQ4100M4	

* Maximum values.

MECHANICAL DATA

The capacitor may be mounted in any position. The PEH 536 is supplied with PVC insulation sleeve, thickness 0.3 mm. Voltage proof of the insulation sleeve = 2.5 kVDC (1 min). The minus pole is marked on the case surface.

ORDERING INFORMATION

For further ordering information please see page 8.
Pos 1-20

P	E	H	5	3	6	J	A	B	4	3	9	0	M	2					
1	2	3	4	5	6	7	8	9	10	11	12	13	14	15	16	17	18	19	20

Pos. 14: Capacitance tolerance M = -20 to +20%

Pos. 15: Pin configuration

Quantities and weights for PEH536

CASE CODE	AC	AD	AE	AF	AG	BB	BC	BD	BE	BF	BG	CB	CC	CD	CE	CF	CG	DB	DC
Weight approx (g)	14	15	17	19	21	19	21	24	27	30	33	24	29	34	39	45	51	32	40
Standard box quantity	100	100	100	100	100	200	100	100	100	100	100	200	100	100	100	100	100	200	100

Quantities and weights for PEH536

CASE CODE	DD	DE	DF	DG	DH	DI	EI	EK	EM	EQ
Weight approx (g)	48	56	64	72	85	88	115	135	155	175
Standard box quantity	100	100	100	100	100	100	25	25	25	25

TYPICAL DATA PEH 536

Fig. 1

$C_T = C(f=100 \text{ Hz}, T_h) / C(f=100 \text{ Hz}, T_h = 20^\circ\text{C})$ vs T_h

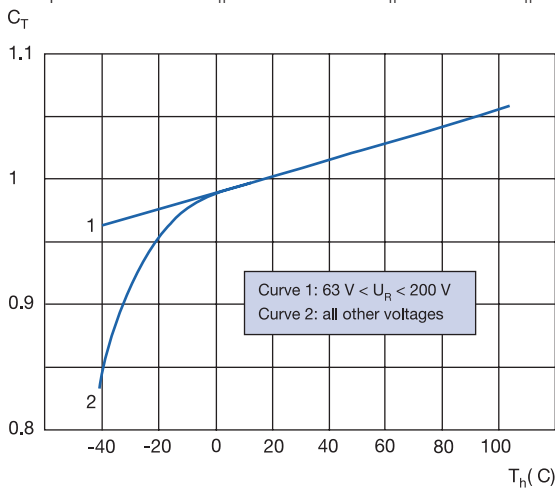

Fig. 4

$k_f = \text{ESR}(f, T_h = 20^\circ\text{C}) / \text{ESR}(f = 100 \text{ Hz}, T_h = 20^\circ\text{C})$ vs f

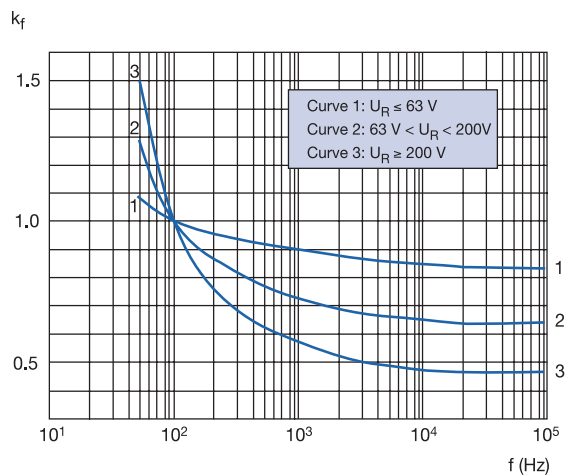

Fig. 2

$K_T = k_T = \text{ESR}(f, T_h) / \text{ESR}(f, T_h = 20^\circ\text{C})$ vs $T_h, U_R < 200 \text{ V}$

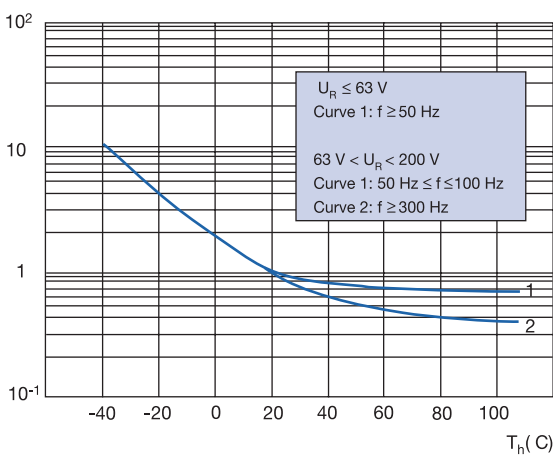
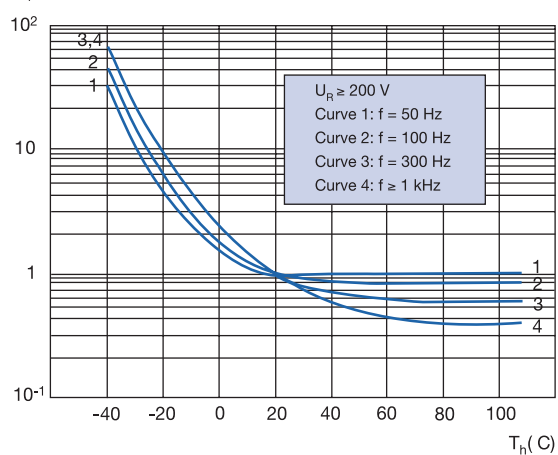

Fig. 5

$K_T = k_T = \text{ESR}(f, T_h) / \text{ESR}(f, T_h = 20^\circ\text{C})$ vs $T_h, U_R \geq 200 \text{ V}$



THERMAL RESISTANCE FOR DIFFERENT CASE SIZES, AS A FUNCTION OF CASE AIR SPEED V

 At ambient temperature $T_a = 40^\circ\text{C}$

Case		Air speed v											
		v=0,5m/s		v=1,0m/s		v=2,0m/s		v=3,0m/s		v=4,0m/s		v=5,0m/s	
D x L	mm	R_{thca}	R_{th}	R_{thca}	R_{th}	R_{thca}	R_{th}	R_{thca}	R_{th}	R_{thca}	R_{th}	R_{thca}	R_{th}
		$^\circ\text{C/W}$		$^\circ\text{C/W}$		$^\circ\text{C/W}$		$^\circ\text{C/W}$		$^\circ\text{C/W}$		$^\circ\text{C/W}$	
22 x 25	AB	24.3	25.1	19.1	20.0	14.8	15.7	13.2	14.1	11.4	12.3	10.3	11.1
22 x 30	AC	21.3	22.5	16.8	18.0	13.2	14.4	11.7	12.9	10.2	11.4	9.2	10.4
22 x 35	AD	19.1	20.5	15.1	16.6	11.9	13.4	10.7	12.1	9.4	10.8	8.5	9.9
22 x 40	AE	17.4	19.0	13.9	15.5	11.0	12.7	9.9	11.5	8.7	10.4	7.9	9.5
22 x 45	AF	16.1	17.6	12.9	14.4	10.4	11.8	9.3	10.8	8.3	9.7	7.5	9.0
22 x 50	AG	15.1	16.8	12.2	14.0	9.8	11.6	8.9	10.6	7.9	9.7	7.2	9.0
25 x 25	BB	21.9	22.8	17.2	18.1	13.4	14.3	11.8	12.6	10.2	11.1	9.2	10.0
25 x 30	BC	19.3	20.2	15.3	16.1	12.0	12.8	10.5	11.3	9.2	10.0	8.2	9.1
25 x 35	BD	17.2	18.2	13.7	14.7	10.8	11.8	9.6	10.6	8.4	9.4	7.6	8.6
25 x 40	BE	15.8	16.9	12.6	13.7	10.0	11.2	8.9	10.0	7.8	8.9	7.1	8.2
25 x 45	BF	14.7	16.2	11.8	13.3	9.4	10.9	8.4	9.9	7.4	8.9	6.8	8.3
25 x 50	BG	13.7	15.2	11.1	12.6	8.9	10.5	8.0	9.5	7.1	8.6	6.5	8.0
30 x 25	CB	18.9	19.5	14.9	15.5	11.7	12.3	10.0	10.6	8.7	9.3	7.8	8.4
30 x 30	CC	16.4	17.1	13.1	13.8	10.2	10.9	8.8	9.5	7.7	8.4	6.9	7.6
30 x 35	CD	14.8	15.6	11.8	12.6	9.3	10.1	8.0	8.9	7.0	7.9	6.3	7.2
30 x 40	CE	13.5	14.3	10.8	11.6	8.6	9.4	7.4	8.2	6.5	7.3	5.9	6.7
30 x 45	CF	12.5	13.3	10.0	10.9	8.0	8.9	7.0	7.8	6.2	7.0	5.6	6.5
30 x 50	CG	11.9	12.9	9.7	10.7	7.8	8.8	6.8	7.8	6.1	7.1	5.5	6.6
35 x 25	DB	16.5	17.0	13.1	13.6	10.5	11.0	8.6	9.1	7.5	8.0	6.7	7.2
35 x 30	DC	14.3	14.7	11.4	11.8	9.2	9.6	7.6	8.0	6.6	7.0	5.9	6.3
35 x 35	DD	12.9	13.4	10.3	10.8	8.3	8.8	6.9	7.4	6.0	6.5	5.4	5.9
35 x 40	DE	11.8	12.5	9.5	10.1	7.7	8.3	6.4	7.1	5.6	6.3	5.1	5.7
35 x 45	DF	10.9	11.6	8.8	9.5	7.1	7.9	6.0	6.7	5.3	6.0	4.8	5.5
35 x 50	DG	10.5	11.3	8.5	9.3	7.0	7.8	5.9	6.7	5.3	6.0	4.8	5.6
35 x 55	DH	9.6	10.3	7.8	8.5	6.4	7.1	5.4	6.1	4.8	5.5	4.4	5.1
35 x 60	DI	9.1	10.2	7.4	8.5	6.2	7.2	5.2	6.3	4.7	5.7	4.3	5.3
40 x 60	EI	8.2	9.0	6.7	7.6	5.5	6.3	4.6	5.5	4.1	5.0	3.8	4.7
40 x 70	EK	7.5	8.5	6.2	7.2	5.1	6.1	4.4	5.4	3.9	4.9	3.6	4.6
40 x 80	EM	7.0	8.3	5.9	7.2	4.9	6.2	4.2	5.5	3.8	5.1	3.5	4.8
40 x 100	EQ	6.4	8.2	5.4	7.2	4.6	6.3	4.1	5.8	3.7	5.4	3.4	5.2

 $(R_{thca} = \text{Thermal resistance between case and ambient})$

Statements of suitability for certain applications are based on our knowledge of typical operating conditions for such applications, but are not intended to constitute – and we specifically disclaim – any warranty concerning suitability for a specific customer application or use. This Information is intended for use only by customers who have the requisite experience and capability to determine the correct products for their application. Any technical advice inferred from this Information or otherwise provided by us with reference to the use of our products is given gratis, and we assume no obligation or liability for the advice given or results obtained.