

Standard Products

ACT4436 Dual Transceiver

for MIL-STD-1553 A/B, MIL-STD-1760 & SAE-AS15531

www.aeroflex.com/Avionics

December 21, 2004

FEATURES

- Small size, light weight and low power dissipation dual transceiver
- +5V / ±15V DC power supply operation
- Outstanding MIL-STD-1553 / SAE-AS15531 performance
- Monolithic construction
- Input and output TTL compatible design
- Designed for commercial, industrial and aerospace applications
- MIL-PRF-38534 compliant devices available
- Aeroflex-Plainview is a Class H & K MIL-PRF-38534 manufacturer
- DSCC Standard Microcircuit Drawing (SMD): 5962-89447

GENERAL DESCRIPTION

The Aeroflex-Plainview ACT4436 is the next generation monolithic transceiver design which provides full compliance with MIL-STD-1553A/B, MIL-STD-1760 and meets SAE-AS15531 requirements in the smallest package with lower pin count than the ACT4487D, for those designs with less board space. The series performs the front-end analog function of inputting and outputting data through a transformer to the MIL-STD-1553 data bus.

Design of these transceivers reflects particular attention to active filter performance. This results in low bit and word error rate with superior waveform purity and minimal zero crossover distortion. Efficient transmitter electrical and thermal design provides low internal power dissipation and heat rise at high as well as low duty cycles.

Each channel of the dual transceiver is completely separate from the other and fully independent. This includes power leads as well as signal lines. Hence, each channel may be connected to a different data bus with no interaction.

TRANSMITTER

The transmitter section accepts bi-phase TTL data at the input and when coupled to the data bus with a 1.4:1 ratio transformer the data bus signal is typically 7.5 Volts P-P at Point A (See Figure 5). When both DATA and $\overline{\text{DATA}}$ inputs are held low or high, the transmitter output becomes a high impedance and is “removed” from the line. In addition, an overriding “INHIBIT” input provides for the removal of the transmitter output from the line. A logic “1” applied to the “INHIBIT” takes priority over the condition of the data inputs and disables the transmitter (See Figure 1 Transmitter Logic Waveform). The Transmitter may be safely operated for an indefinite period with the bus (Point A) short circuited at 100% duty cycle.

RECEIVER

The Receiver section accepts bi-phase differential data at the input and produces two TTL signals at the output. The outputs are DATA and $\overline{\text{DATA}}$, and represent positive and negative excursions of the input beyond a pre-determined threshold (See Figure 2 Receiver Logic Waveform).

The pre-set internal thresholds will detect data bus signals exceeding 1.20 Volts P-P and reject signals less than 0.6 Volts P-P when used with a transformer (See Figure 5 for transformer data and typical connections).

A low level at the Strobe input inhibits the DATA and $\overline{\text{DATA}}$ outputs. If unused, a 2K pull-up to +5 Volts is recommended.



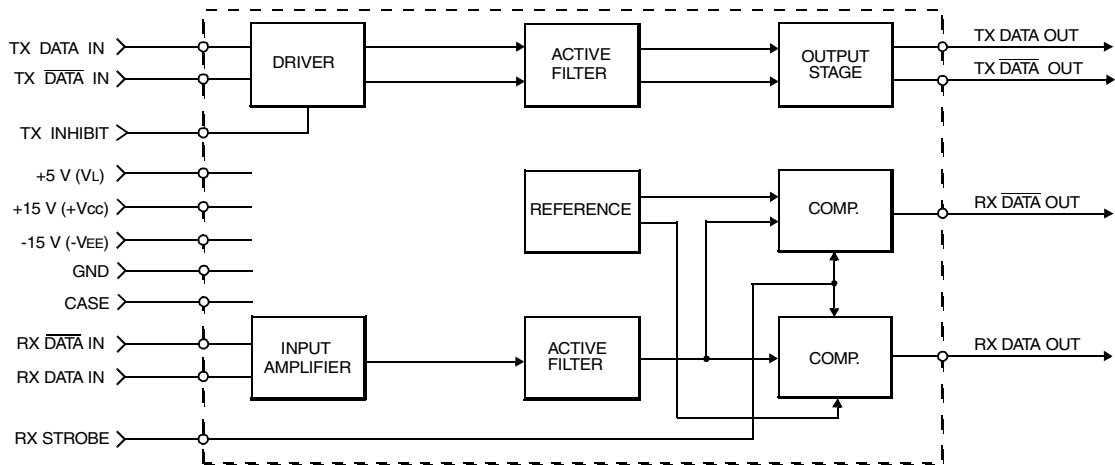

BLOCK DIAGRAM (WITHOUT TRANSFORMER)

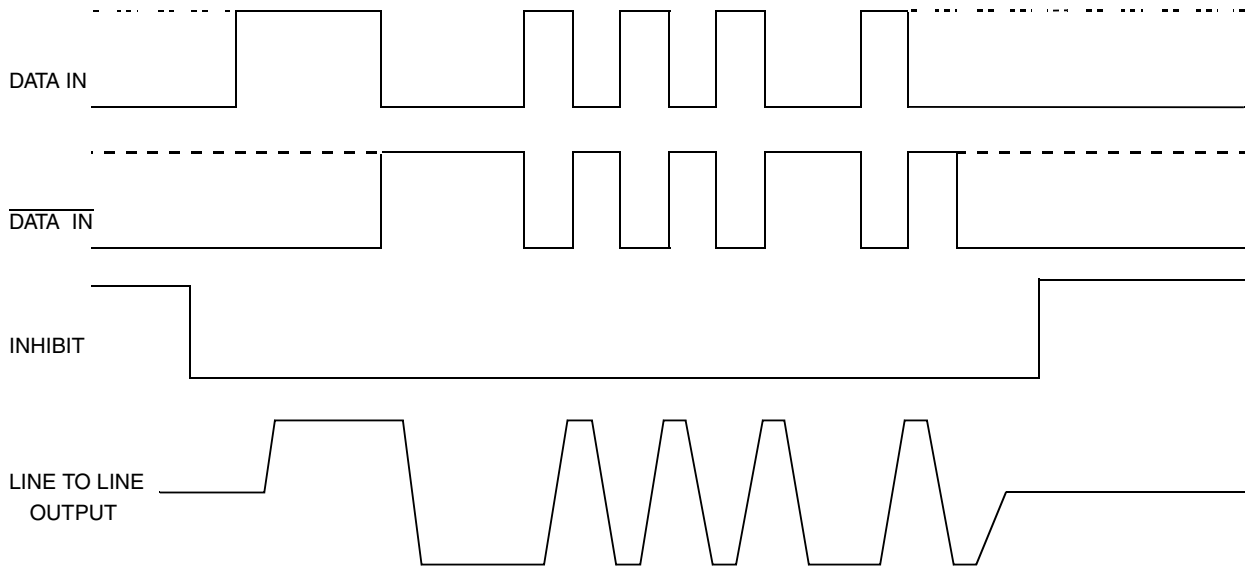

Note: DATA and $\overline{\text{DATA}}$ inputs must be complementary waveforms or 50% duty cycle average, with no delays between them, and must be in the same state during off times (both high or low).

FIGURE 1 – TRANSMITTER LOGIC WAVEFORMS IDEALIZED

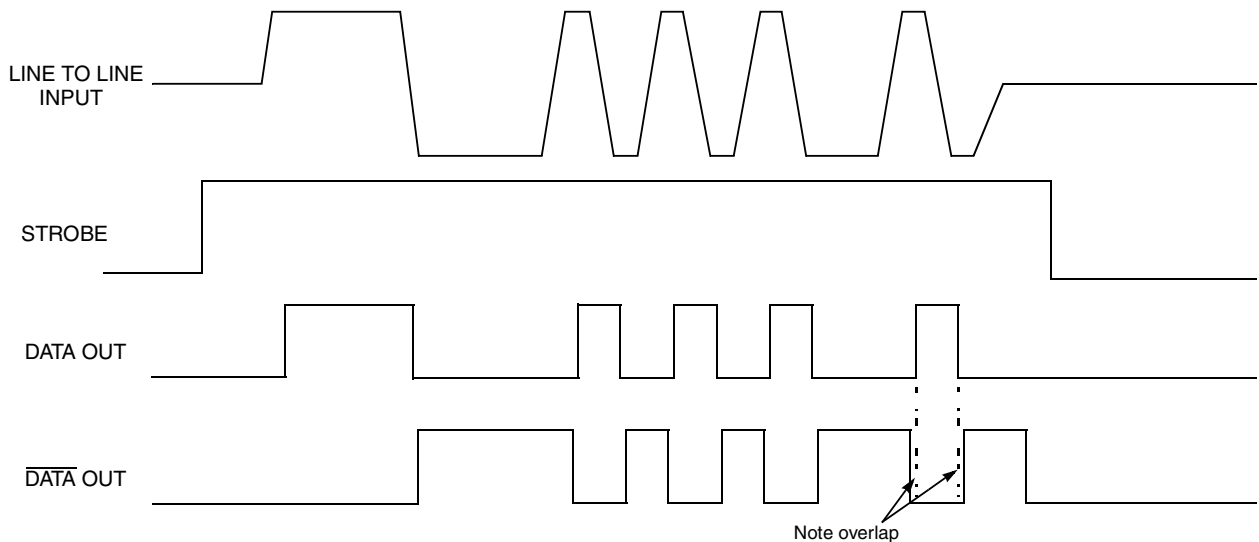

Note: Outputs shown are for ACT4436D and are Inverted for the ACT4436DI.

FIGURE 2 – RECEIVER LOGIC WAVEFORMS IDEALIZED

ABSOLUTE MAXIMUM RATINGS

Operating case temperature	-55°C to +125°C
Storage case temperature	-65°C to +150°C
Power supply voltage VCC VEE VL	-0.3 VDC to +18 VDC +0.3 VDC to -18 VDC -0.3 VDC to +7.0 VDC
Logic input voltage	-0.3VDC to +5.5VDC
Receiver differential input	±40 Vp-p
Receiver input voltage (common mode)	±10V
Driver peak output current	200 mA
Total package power dissipation over the full operating case temperature range	2.5 Watts (Note: Normal operation conditions require one transmitter on and the other off at any given time)
Maximum junction to case temperature	10°C
Thermal resistance – Junction to case	4°C/W

ELECTRICAL CHARACTERISTICS – DRIVER SECTION

INPUT CHARACTERISTICS, TX DATA IN OR TX DATA IN (Notes 2 & 3 Apply)

Parameter	Condition	Symbol	Min	Typ	Max	Unit
"0" Input Current	V _{IN} = 0.4V	I _{ILD}	-	-0.2	-0.2	mA
"1" Input Current	V _{IN} = 2.7V	I _{IHD}	-	1	40	µA
"0" Input Voltage		V _{ILD}	-	-	0.7	V
"1" Input Voltage		V _{IHD}	2.0	-	-	V

INHIBIT CHARACTERISTICS

"0" Input Current	V _{IN} = 0.4V	I _{ILI}	-	-0.1	-0.2	mA
"1" Input Current	V _{IN} = 2.7V	I _{IHI}	-	1.0	40	µA
"0" Input Voltage		V _{ILI}	-	-	0.7	V
"1" Input Voltage		V _{IHI}	2	-	-	V
Delay from TX inhibit, (0→1) to inhibited output		t _{DXOFF}	-	175	200	nS
Delay from TX inhibit, (1→0) to active output		t _{DXON}	-	90	200	nS
Differential Output Noise, inhibit mode		V _{NOI}	-	2	10	mVp-p
Differential Output Impedance (inhibited) Note 1 See Figure 5	Point B	Z _{OI}	2K	-	-	Ω
	Point C	Z _{OI}	1K	-	-	Ω

OUTPUT CHARACTERISTICS

Differential output level	Figure 5 Point A	V _O	6	7.5	9	Vp-p
Rise and fall times (10% to 90% of p-p output)		t _r	100	160	200	nS
Output offset. See Figure 3. 2.5 µS after midpoint crossing of the parity bit of the last word of a 660µS message.		V _{OS}	-	-	±90	mVpeak
Delay from 50% point of TX DATA or TX DATA input to zero crossing of differential signal		t _{DTX}	-	100	200	nS

ELECTRICAL CHARACTERISTICS – RECEIVER SECTION

Parameter	Condition	Symbol	Min	Typ	Max	Unit
Differential Voltage Range (See Figure 5, Point B)	TXFMR 1.4:1	V_{IDR}	-	14	20	V _{pk}
Common Mode Rejection Ratio (Note 3)		CMRR	45	-	-	dB
"1" State – Rx Data or Rx $\overline{\text{Data}}$ Output	$I_{OH} = -0.4 \text{ mA}$	V_{OH}	2.5	3.7	-	V
"0" State – Rx Data or Rx $\overline{\text{Data}}$ Output	$I_{OI} = 4 \text{ mA}$	V_{OL}	-	0.35	0.5	V
Delay (average) from Differential Input Zero Crossings to RX DATA and RX $\overline{\text{Data}}$ Output 50% points		t_{DRX}	-	270	400	nS
Input Threshold Voltage (referred to the bus)	100KHz–1MHz	V_{TH}	0.60	0.75	1.15	V _{p-p}

STROBE CHARACTERISTICS (LOGIC "0" INHIBITS OUTPUT)

"0" Input Current	$V_S = 0.4V$	I_{IL}	-	-0.2	-0.4	mA
"1" Input Current	$V_S = 2.7V$	I_{IH}	-	1	+40	μA
"0" Input Voltage		V_{IL}	-	-	0.7	V
"1" Input Voltage		V_{IH}	2.0	-	-	V
Strobe Delay (Turn-on or Turn-off)		t_{SD}	-	50	100	nS

POWER DATA

POWER SUPPLY CURRENTS – PER CHANNEL

Transmitter Standby	Note 4	I_{CC}	-	0	1	mA
		I_{EE}	-	12	16	
		I_L	-	18	30	
25% Duty Cycle		I_{CC}	-	45	50	
	I_{EE}	-	12	20		
	I_L	-	18	30		
50% Duty Cycle	I_{CC}	-	90	100		
	I_{EE}	-	12	20		
	I_L	-	18	30		
100% Duty Cycle	I_{CC}	-	180	200		
	I_{EE}	-	12	20		
	I_L	-	18	30		

POWER SUPPLY VOLTAGE

$\pm 15V$ Operating Power Supply Voltage Range	V_{CC}	+14.25	+15.00	+15.75	V
	V_{EE}	-14.25	-15.00	-15.75	
+5V Operating Power Supply Voltage Range	V_L	+4.50	+5.00	+5.50	V

NOTES:

- Power on or off, measured from 75KHz to 1MHz at Point A and transformer self impedance of 3K Ω minimum at 1MHz.
- Power Supplies: $\pm 15VDC \pm 0.75V$ & $+5VDC \pm 0.5V$, bypassed by by 10 μF (Tantalum recommended) Capacitor minimum. All measurements & specifications apply over the temperature range of -55°C to +125°C (case temperature) unless otherwise specified.
- When measured as shown in Figure 5 with $\pm 10Vp$, line to ground, DC to 2MHz.
- Typical power is measured with V_{bus} at Point A = 7.5 V_{p-p}.

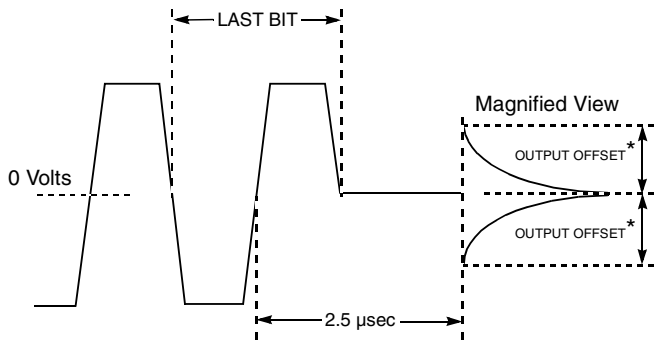

*Offset measured at Point A in Figure 5

FIGURE 3 – TRANSMITTER (TX) OUTPUT OFFSET

Transformer Coupled Stub

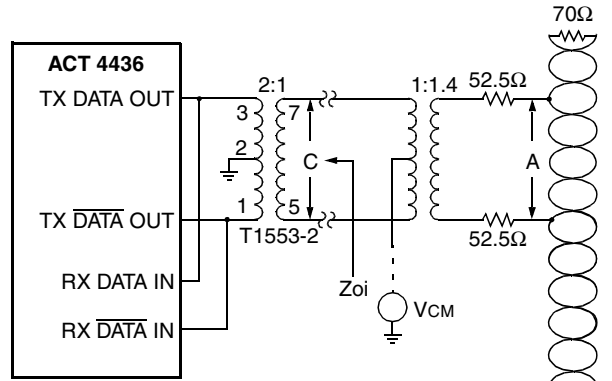

Direct Coupled Stub

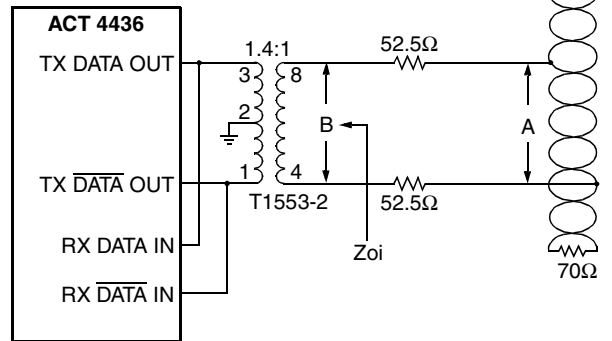

Transformer Model use Technitrol Part# 1553-2 or equivalent

FIGURE 5 – TYPICAL 1553 BUS CONNECTIONS

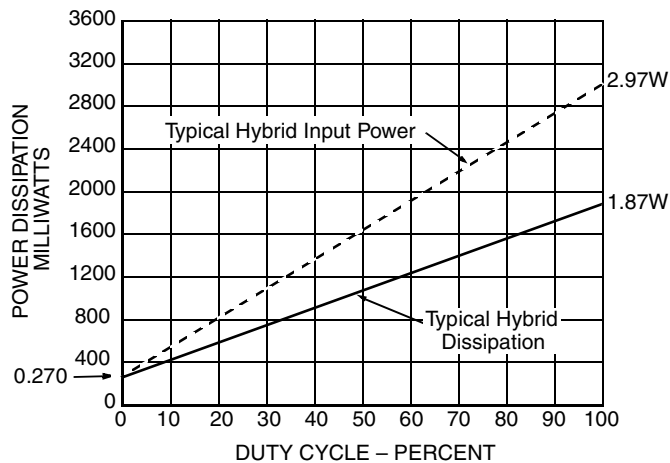

Note: $V_{CC} = +15V$, $V_{EE} = -15V$, $V_L = +5V$, Transformer ratio 1.4:1, V_{BUS} (Point A) at 7.5V_{P-P}.

FIGURE 4 – POWER DISSIPATION VS. DUTY CYCLE
 (Total, hybrid with one channel transmitting and the other not powered – 100% Duty Cycle)

PIN NUMBERS & FUNCTIONS

Pin #	Function	Channel
1	TX DATA OUT / RX DATA IN	A
2	TX $\overline{\text{DATA}}$ OUT / RX $\overline{\text{DATA}}$ IN	A
3	GROUND	A
4	RX STROBE	A
5	RX $\overline{\text{DATA}}$ OUT	A
6	RX DATA OUT	A
7	CASE	
8	TX DATA OUT / RX DATA IN	B
9	TX $\overline{\text{DATA}}$ OU / RX $\overline{\text{DATA}}$ IN	B
10	GROUND	B
11	RX STROBE	B
12	RX $\overline{\text{DATA}}$ OUT	B
13	RX DATA OUT	B
14	NC	
15	GROUND	B
16	-VEE	B
17	VL	B
18	TX INHIBIT	B
19	TX $\overline{\text{DATA}}$ IN	B
20	TX DATA IN	B
21	+VCC	B
22	GROUND	A
23	-VEE	A
24	VL	A
25	TX INHIBIT	A
26	TX $\overline{\text{DATA}}$ IN	A
27	TX DATA IN	A
28	+VCC	A

CONFIGURATIONS AND ORDERING INFORMATION

Model No.	DSCC No.	Receiver Data level	Case	Configuration
ACT4436-D	5962-TBA	Normally Low	Plug In	Dual
ACT4436-DI	5962-8944708HUA/C	Normally High		
ACT4436-DF	5962-TBA	Normally Low	Flat Package	
ACT4436-DFI	5962-8944708HZA/C	Normally High		

PACKAGE CONFIGURATION OUTLINES

Plug In Package Outline

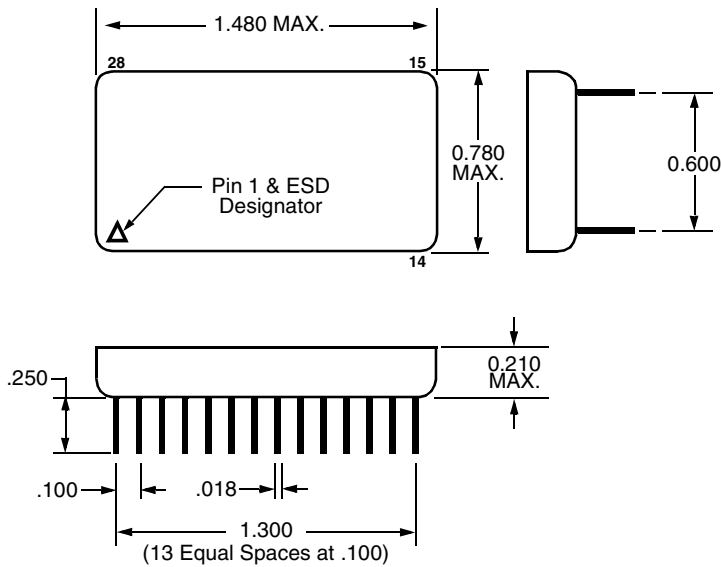

Flat Package Outline

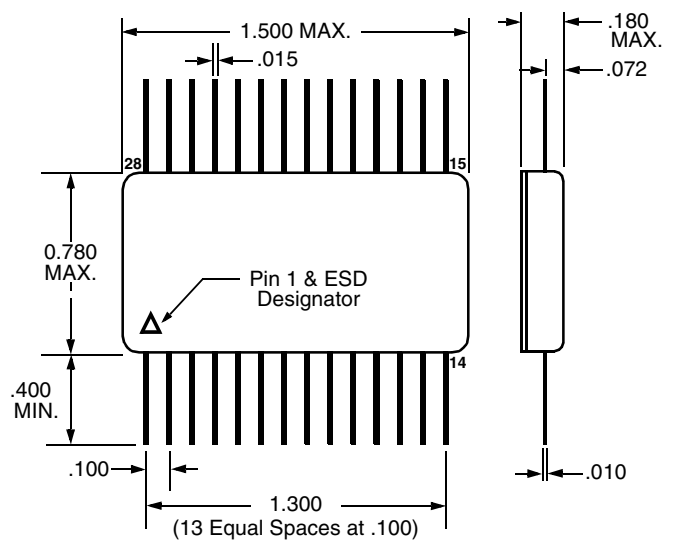

PLAINVIEW, NEW YORK
Toll Free: 800-THE-1553
Fax: 516-694-6715

INTERNATIONAL
Tel: 805-778-9229
Fax: 805-778-1980

NORTHEAST
Tel: 603-888-3975
Fax: 603-888-4585

SE AND MID-ATLANTIC
Tel: 321-951-4164
Fax: 321-951-4254

WEST COAST
Tel: 949-362-2260
Fax: 949-362-2266

CENTRAL
Tel: 719-594-8017
Fax: 719-594-8468

www.aeroflex.com info-ams@aeroflex.com



Aeroflex Microelectronic Solutions reserves the right to change at any time without notice the specifications, design, function, or form of its products described herein. All parameters must be validated for each customer's application by engineering. No liability is assumed as a result of use of this product. No patent licenses are implied.



Our passion for performance is defined by three attributes represented by these three icons: solution-minded, performance-driven and customer-focused