

Standard Products

ACT4479D Dual Transceiver for H009 Specification

www.aeroflex.com/Avionics

October 1, 2008



FEATURES

- Dual transceiver meets McDonnell Douglas H009 data bus specifications
- Low standby power
- Low power dissipation at full output power
- Operates with $\pm 12V$ to ± 15 and $+5V$ power supplies
- Monolithic construction using linear ASICs
- Packaging – Low profile metal hermetic
 - 0.78"W x 1.5"L x 0.180"H
- Designed for commercial, industrial and aerospace applications
- Aeroflex is a Class H & K MIL-PRF-38534 Manufacturer

DESCRIPTION

The Aeroflex Plainview transceiver model ACT4479D is a new generation monolithic transceiver which provides compliance with H009 data bus requirements with the lowest standby power consumption available using three DC power supplies operation. The dual channel ACT4479D performs the front-end analog function of inputting and outputting data through a transformer to a H009 data bus.

Design of these transceivers reflects particular attention to active filter performance. This results in low bit and word error rate with superior waveform purity and minimal zero crossover distortion. The active filter design provides the required H009 low harmonic distortion waveform without increasing the pulse delay characteristics significantly. Efficient transmitter electrical and thermal design provides low internal power dissipation and heat rise at high and well as low duty cycles. The receiver input threshold is set internally.

TRANSMITTER

The Transmitter section accepts complementary TTL data at the input, and when coupled to the data bus with a 1:1 transformer, isolated on the transceiver side with two 34 Ohm bus terminating resistors, with the bus terminated by a 175 Ohm resistor, the data bus signal produced is 20VP-P nominal at A-A' (See Figure 5). When both DATA and $\overline{\text{DATA}}$ inputs are held low or high, the transmitter output remains a low impedance and signal is "removed" from the line. In addition, an overriding "INHIBIT" input returns the output to a high impedance state. A logic "1" applied to the "INHIBIT" takes priority over the condition of the data inputs and disables the transmitter (See Transmitter Logic Waveforms - Figure 1).

The transmitter utilizes an active filter to suppress harmonics above 1 MHz to meet H009 specifications. The transmitter may be safely operated for an indefinite period at 100% duty cycle into a data bus short circuit.

RECEIVER

The Receiver section accepts bi-phase differential data at the input and produces two TTL signals at the output. The outputs are DATA and $\overline{\text{DATA}}$, and represent positive and negative excursions of the input beyond a pre-determined threshold (See Receiver Logic Waveforms - Figure 2).

The internal threshold is nominally set to detect data bus signals exceeding 2.0VP-P when used with a 1:1 turns ratio transformer (See Figure 5 for transformer data and typical connection).

A low level at the Strobe input inhibits the DATA and $\overline{\text{DATA}}$ outputs (Pin is internally pulled up).

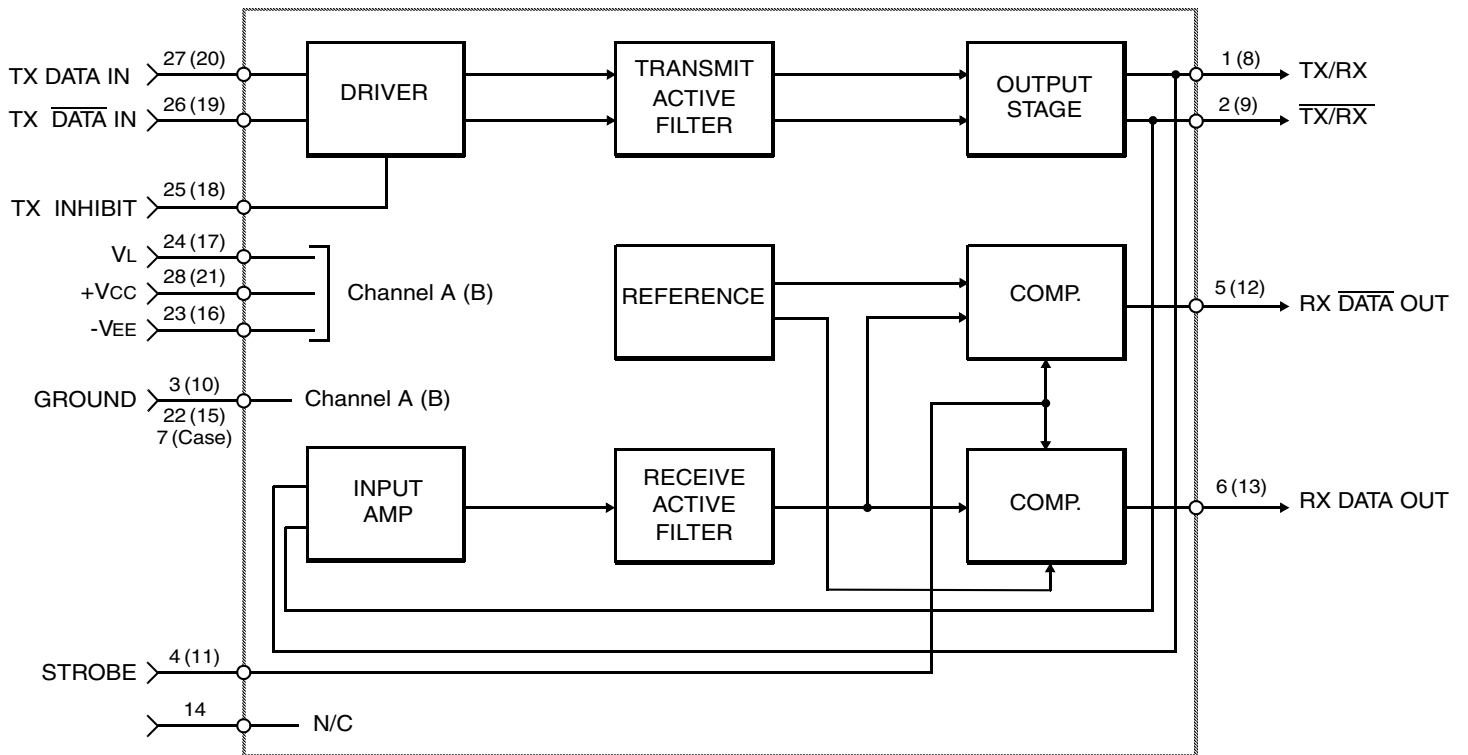

**BLOCK DIAGRAM
(WITHOUT TRANSFORMER, CHANNEL A SHOWN)
CHANNEL A (CHANNEL B)**

DATA	$\overline{\text{DATA}}$	INHIBIT	OUTPUT
X	X	H	High Z
H	H	L	Low Z (No signal)
L	L	L	
H	L	L	Low Z (Signal)
L	H	L	

FIGURE 1A – TX OUTPUT TRUTH TABLE

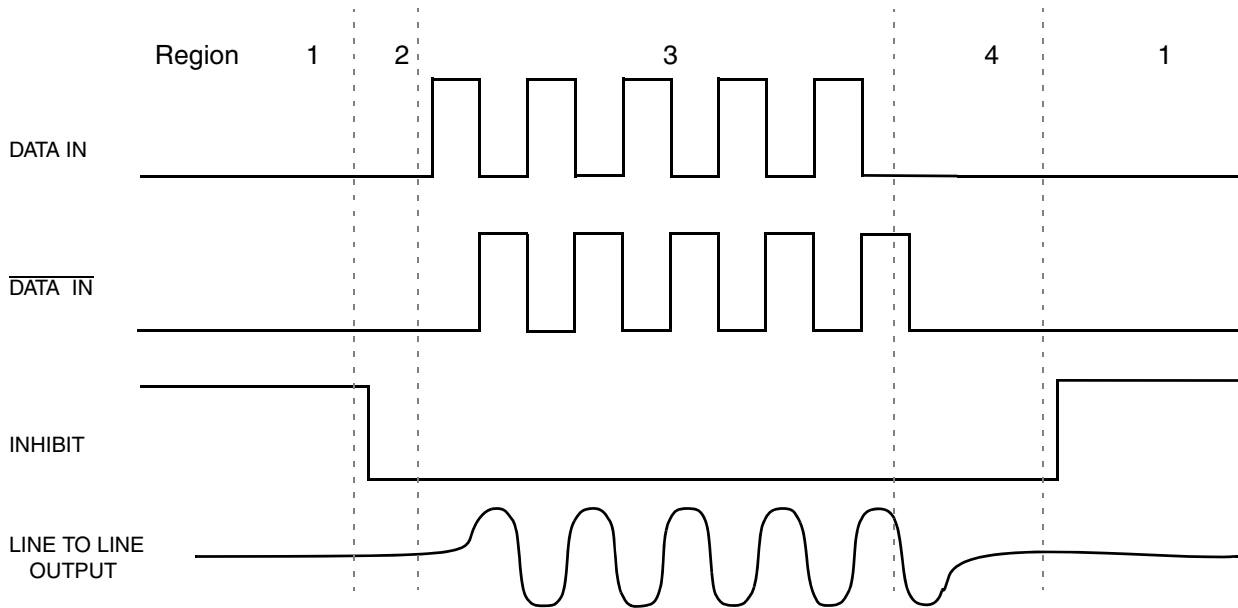

- Notes: 1. Data and $\overline{\text{DATA}}$ inputs must be complementary waveforms or 50% duty cycle average, with no delays between them, and in the same state during the off time (both high and low).
 2. **Region 1;** no output signal, High Z state, (Receive Mode), **Region 2;** No Output signal, Low Z state, **Region 3;** Transmitter signal on, low Z (Transmitter mode), **Region 4;** No Output signal, Low Z state, (Terminate Mode).

FIGURE 1B – TRANSMITTER LOGIC WAVEFORMS

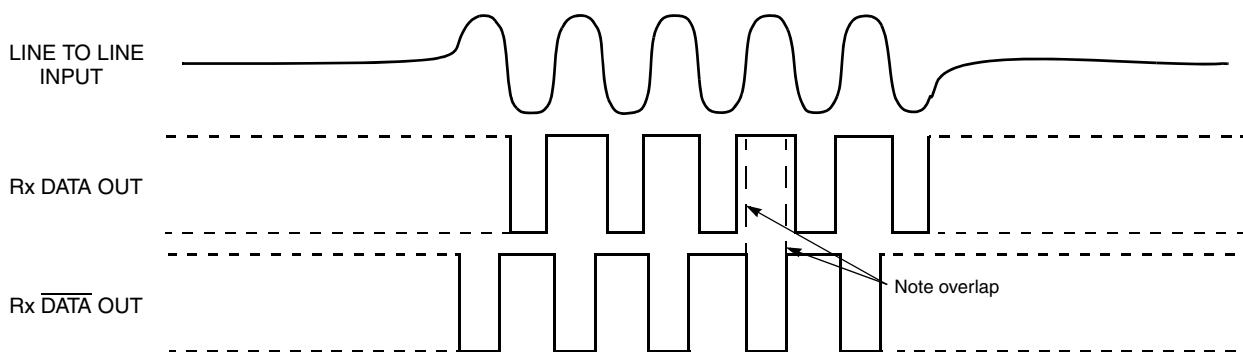

FIGURE 2 – RECEIVER LOGIC WAVEFORMS

ABSOLUTE MAXIMUM RATINGS

Operating Case Temperature	-55°C to +125°C	
Storage Case Temperature	-65°C to +150°C	
Power Supply Voltages	±18 V	+7 V
Logic Input Voltage	-0.3 V to +5.5 V	
Receiver Differential Input	±40 V	
Receiver Input Voltage (Common Mode)	±10V	
Driver Peak Output Current	150 mA	
Total Package Power Dissipation over the Full Operating Case Temperature Range	3.6 Watts	
Maximum Junction to Case Temperature (100% duty cycle)	18°C	
Junction-Case, Thermal Resistance	5°C/W	

ELECTRICAL CHARACTERISTICS – DRIVER SECTION 1/ 2/

INPUT CHARACTERISTICS, TX DATA IN OR TX $\overline{\text{DATA}}$ IN

Parameter	Condition	Symbol	Min	Typ	Max	Unit
"0" Input Current	$V_{IN} = 0.4V$	I_{ILD}	-	-0.2	-0.4	mA
"1" Input Current	$V_{IN} = 2.7V$	I_{IHD}	-	1	40	μA
"0" Input Voltage	-	V_{ILD}	-	-	0.7	V
"1" Input Voltage	-	V_{IHD}	2.0	-	-	V

INHIBIT CHARACTERISTICS

"0" Input Current	$V_{IN} = 0.4V$	I_{ILI}	-	-0.2	-0.4	mA
"1" Input Current	$V_{IN} = 2.7V$	I_{IHI}	-	1.0	40	μA
"0" Input Voltage	-	V_{ILI}	-	-	0.7	V
"1" Input Voltage	-	V_{IHI}	2	-	-	V
Delay from TX inhibit, (0→1) to inhibited output	-	t_{DXOFF}	-	300	500	nS
Delay from TX inhibit, (1→0) to active output	-	t_{DXON}	-	200	400	nS
Differential Output Noise, inhibit mode	-	V_{NOI}	-	2	10	mVp-p
Differential Output Impedance (inhibited)	4/	Z_{OI}	10K	-	-	Ω

OUTPUT CHARACTERISTICS

Differential output level (175Ω)	Point A - A'	V_O	16	20	24	V p-p
Rise and Fall Times (10% to 90% of p-p output)	-	t_R & t_F	200	260	300	nS
Output Offset, Figure4 5/	Point A - A'	V_{OS}	-	-	±260	mV peak
Delay from 50% point of TX DATA or TX $\overline{\text{DATA}}$ input to zero crossing of differential signal (Note 1)	-	$t_{D\text{TX}}$	-	280	400	nS

ELECTRICAL CHARACTERISTICS – RECEIVER SECTION 1/ 2/

Parameter	Condition	Symbol	Min	Typ	Max	Unit
Differential Voltage Range 3/	Point A-A'	V_{IDR}	-	-	20	V _{PEAK}
Common Mode Rejection Ratio 3/	-	CMRR	45	-	-	dB

STROBE CHARACTERISTICS (Logic '0' Inhibits Output) (NOTE: If not used, a 1K pullup to 5V is recommended)

"0" Input Current	$V_S = 0.4V$	I_{IL}	-	-0.2	-0.4	mA
"1" Input Current	$V_S = 2.7V$	I_{IH}	-	1	+40	μA
"0" Input Voltage	-	V_{IL}	-	-	0.7	V
"1" Input Voltage	-	V_{IH}	2.0	-	-	V
Strobe Delay (turn-on or turn-off)	-	$t_{SD(ON/OFF)}$	-	90	150	nS

THRESHOLD CHARACTERISTICS (Sinewave Input)

Internal Threshold Voltage, Point A-A' Figure 5	1MHz	V_{TH}	1.5	2.0	3.0	V _{P-P}
---	------	----------	-----	-----	-----	------------------

OUTPUT CHARACTERISTICS, RX DATA AND RX DATA

"1" State	$I_{OH} = -0.4mA$	V_{OH}	2.5	3.6	-	V
"0" State	$I_{OL} = 4mA$	V_{OL}	-	0.35	0.5	V
Delay, (average) from differential input zero crossings to RX DATA and RX DATA output	6/ 50% points	t_{DRX}	-	300	450	nS

POWER SUPPLY CURRENT PER CHANNEL 1/ 2/

$V_{CC} = +12V$ to $+15V$, $V_{EE} = -12V$ to $-15V$, $V_L = +5V$

Duty Cycle	Condition	Symbol	Typ	Max	Unit
Transmitter Standby	Point A - A' $Z_O = 175\Omega$, $V_O = 21VP-P$ Figure 5	I_{CC}	6	10	mA
		I_{EE}	15	25	
		I_L	22	30	
25%		I_{CC}	25	35	
		I_{EE}	36	45	
		I_L	22	30	
50%		I_{CC}	34	45	
		I_{EE}	45	55	
		I_L	22	30	
100%		I_{CC}	49	60	
		I_{EE}	60	70	
		I_L	22	30	

Notes:

- $V_{CC} = +15V$ to $\pm 0.75V$, $V_{EE} = -15V$ to $\pm 0.75V$, $V_{IL} = +5V$ to $\pm 0.5V$, $T_c = -55^\circ C$ to $+125^\circ C$, unless otherwise specified.
- All typical values are measured at $+25^\circ C$.
- Characteristics guaranteed by design, not production tested.
- Power ON/OFF, measured 1MHz at Point A-A' Figure 4.
- At point A-A' on Figure 4 or 5, 2.5 μS after midpoint crossing of the parity bit of the last word.
- This test is performed while the Transceiver is reading its own transmission. This condition is called "Wraparound". Standard TTL loads applied to RX DATA Outputs.

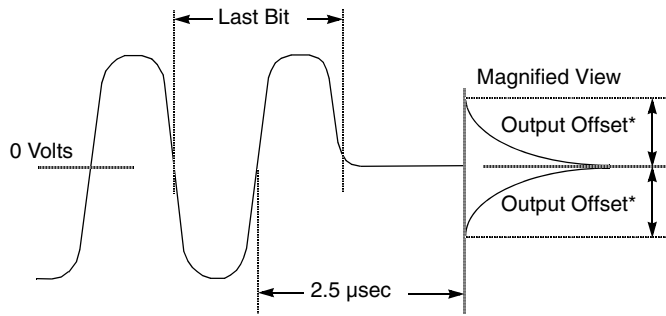

*Offset measured at point A-A' in Figure 5

FIGURE 4 – TRANSMITTER (TX) OUTPUT OFFSET

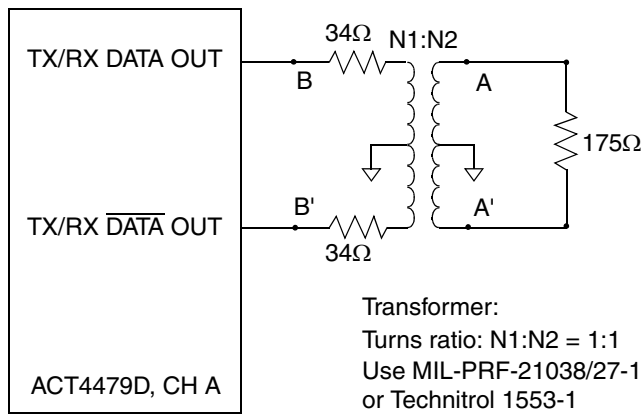
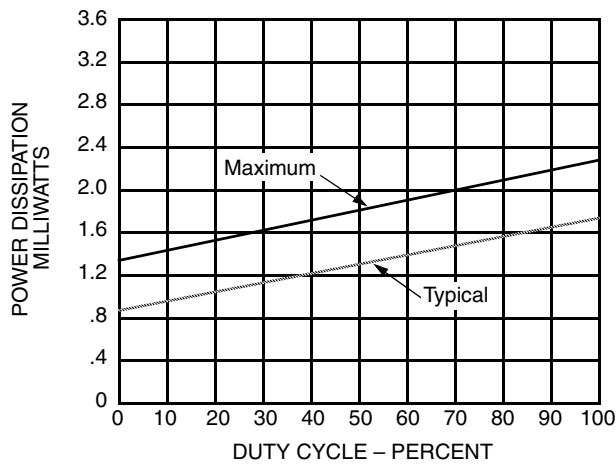

FIGURE 5 – TYPICAL TRANSFORMER CONNECTION



Note: V_{CC} = +15VDC, V_{EE} = -15VDC, V_{BUS} (Point A-A') at 21VP-P

FIGURE 6 – PACKAGE (PWR_{IN} - PWR_{LOAD}) POWER DISSIPATION vs DUTY CYCLE (Total Hybrid with one channel transmitting and the other in standby)

FIGURE 7 – LEAD NUMBERS & FUNCTIONS

Pin #	Function	Channel
1	TX DATA OUT/ RX DATA IN	A
2	TX $\overline{\text{DATA}}$ OUT/ RX $\overline{\text{DATA}}$ IN	A
3	GROUND	A
4	RX STROBE	A
5	RX $\overline{\text{DATA}}$ OUT	A
6	RX DATA OUT	A
7	CASE	-
8	TX DATA OUT/ RX DATA IN	B
9	TX $\overline{\text{DATA}}$ OUT/ RX $\overline{\text{DATA}}$ IN	B
10	GROUND	B
11	RX STROBE	B
12	RX $\overline{\text{DATA}}$ OUT	B
13	RX DATA OUT	B
14	NC	-
15	GROUND	B
16	-VEE	B
17	VL	B
18	TX INHIBIT	B
19	TX $\overline{\text{DATA}}$ IN	B
20	TX DATA IN	B
21	+VCC	B
22	GROUND	A
23	-VEE	A
24	VL	A
25	TX INHIBIT	A
26	TX $\overline{\text{DATA}}$ IN	A
27	TX DATA IN	A
28	+VCC	A

CONFIGURATIONS AND ORDERING INFORMATION

Model No.	Screening	DESC SMD	Receiver Data level	Case
ACT4479-D	Military Temperature, -55°C to +125°C Screened in accordance with MIL-PRF-38534, Class H	Pending	Normally Low	Plug-In
ACT4479-DI			Normally High	
ACT4479-DF			Normally Low	Flat Pack
ACT4479-DFI			Normally High	
ACT4479-D-7	Commercial flow, +25°C testing only	NA	Normally Low	Plug-In
ACT4479-DI-7			Normally High	
ACT4479-DF-7			Normally Low	Flat Pack
ACT4479-DFI-7			Normally High	

PACKAGE CONFIGURATION OUTLINE

Flat Package

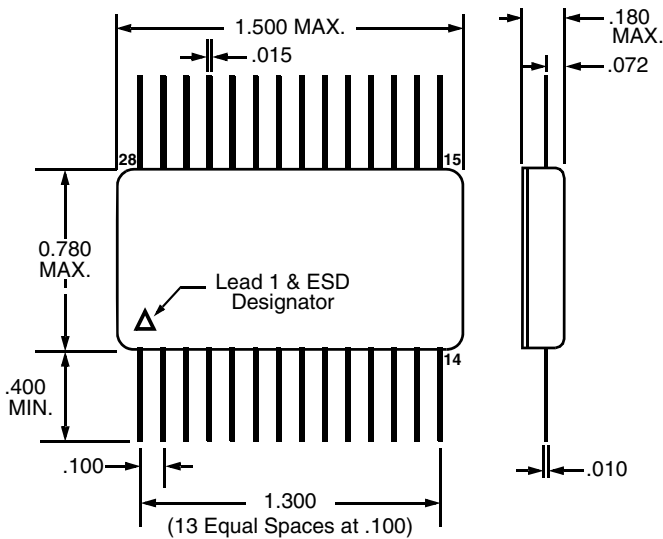

Plug-In Package

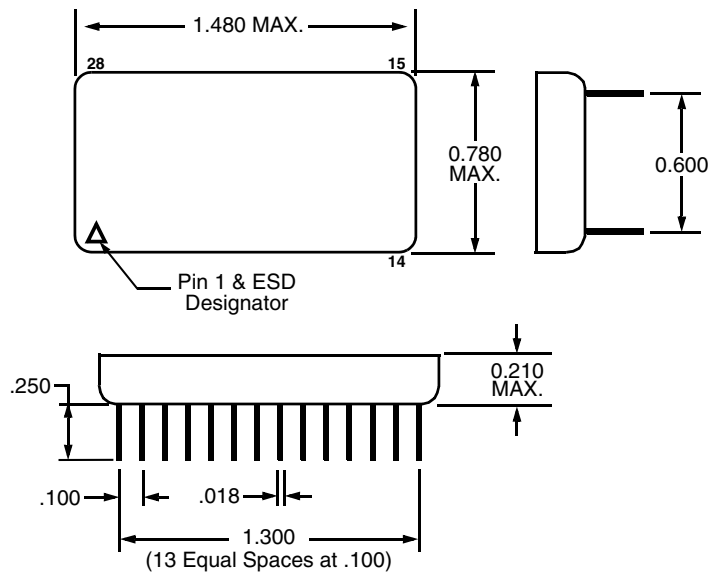

Notes

1. Dimensions shown are in inches
2. Pins are equally spaced at 0.100±0.002 tolerance, non-cumulative, each row

PLAINVIEW, NEW YORK
Toll Free: 800-THE-1553
Fax: 516-694-6715

INTERNATIONAL
Tel: 805-778-9229
Fax: 805-778-1980

NORTHEAST
Tel: 603-888-3975
Fax: 603-888-4585

SE AND MID-ATLANTIC
Tel: 321-951-4164
Fax: 321-951-4254

WEST COAST
Tel: 949-362-2260
Fax: 949-362-2266

CENTRAL
Tel: 719-594-8017
Fax: 719-594-8468

www.aeroflex.com info-ams@aeroflex.com



Aeroflex Microelectronic Solutions reserves the right to change at any time without notice the specifications, design, function, or form of its products described herein. All parameters must be validated for each customer's application by engineering. No liability is assumed as a result of use of this product. No patent licenses are implied.



Our passion for performance is defined by three attributes represented by these three icons: solution-minded, performance-driven and customer-focused