

UT63M1XX MIL-STD-1553A/B Bus Transceiver

Data Sheet



Sept. 1999

FEATURES

- ❑ Full conformance to MIL-STD-1553A and 1553B
- ❑ Completely monolithic bipolar technology
- ❑ Low power consumption
- ❑ Fit and functionally compatible to industry standard 631XX series
- ❑ Idle low encoding version
- ❑ Flexible power supply voltages: $V_{CC}=+5V$, $V_{EE}=-12V$ or $-15V$, and $V_{CCA}=+5V$ to $+12V$ or $+5V$ to $+15V$
- ❑ Full military operating temperature range, $-55^{\circ}C$ to $+125^{\circ}C$, screened to QML Q or QML V requirements
- ❑ Standard Military Drawing available

INTRODUCTION

The monolithic UT63M1XX Transceivers are complete transmitter and receiver pairs conforming fully to MIL-STD-1553A and 1553B. Encoder and decoder interfaces are idle low. UTMC's advanced bipolar technology allows the positive analog power to range from +5V to +12V or +5V to +15V, providing more flexibility in system power supply design.

The receiver section of the UT63M1XX series accepts biphasemodulated Manchester II bipolar data from a MIL-STD-1553 data bus and produces TTL-level signal data at its RXOUT and \overline{RXOUT} outputs. An external RXEN input enables or disables the receiver outputs.

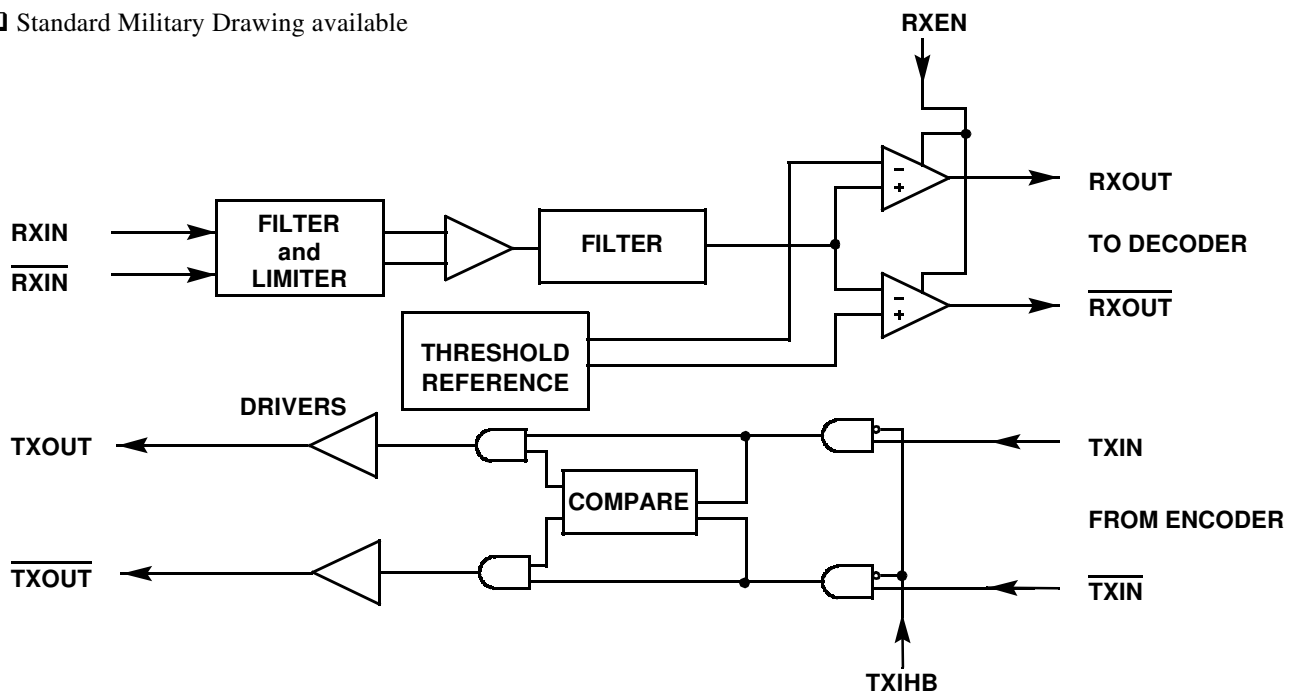

Figure 1. Functional Block Diagram

The transmitter section accepts biphasic TTL-level signal data at its TXIN and $\overline{\text{TXIN}}$ and produces MIL-STD-1553 data signals. The transmitter's output voltage is typically $42V_{pp}$, L-L. Activating the TXIHB input or setting both data inputs to the same logic level disables the transmitter.

The UT63M1XX series offers a monolithic transmitter and receiver packaged in either single channel (24-pin) or dual-channel (36-pin) configurations designed for use in any MIL-STD-1553 application.

Legend for TYPE field:

- TI = TTL input
- TO = TTL output
- DO = Differential output
- DI = Differential input
- () = Channel designator

TRANSMITTER

NAME	PACKAGE PIN		TYPE	DESCRIPTION
	SINGLE	DUAL		
TXOUT (A)	1	1	DO	Transmitter outputs: TXOUT and TXOUT are differential data signals.
TXOUT (B)	N/A	10	DO	
$\overline{\text{TXOUT}}$ (A)	2	2	DO	$\overline{\text{TXOUT}}$ is the complement of TXOUT.
$\overline{\text{TXOUT}}$ (B)	N/A	11	DO	
TXIHB (A)	21	34	TI	Transmitter inhibit: this is an active high input signal.
TXINB (B)	N/A	25	TI	
TXIN (A)	22	35	TI	Transmitter inputs: TXIN and TXIN are complementary TTL-level Manchester II encoder inputs.
TXIN (B)	N/A	26	TI	
$\overline{\text{TXIN}}$ (A)	23	36	TI	TXIN is the complement of TXIN input.
$\overline{\text{TXIN}}$ (B)	N/A	27	TI	

RECEIVER

NAME	PACKAGE PIN		TYPE	DESCRIPTION
	SINGLE	DUAL		
RXOUT (A)	7	5	TO	Receiver outputs: RXOUT and $\overline{\text{RXOUT}}$ are complementary Manchester II decoder outputs.
RXOUT (B)	N/A	14	TO	
RXOUT (A)	10	8	TO	$\overline{\text{RXOUT}}$ is the complement of RXOUT output
$\overline{\text{RXOUT}}$ (B)	N/A	17	TO	
RXEN (A)	8	6	TI	Receiver enable/disable: This is an active high input signal.
RXEN (B)	N/A	15	TI	
RXIN (A)	15	29	DI	Receiver inputs: RXIN and $\overline{\text{RXIN}}$ are biphas-modulated Manchester II bipolar inputs from MIL-STD-1553 data bus.
RXIN (B)	N/A	20	DI	
RXIN (A)	16	30	DI	$\overline{\text{RXIN}}$ is the complement of RXIN input.
$\overline{\text{RXIN}}$ (B)	N/A	21	DI	

POWER AND GROUND

NAME	PACKAGE PIN		TYPE	DESCRIPTION
	SINGLE	DUAL		
V _{CC} (A)	20	33	PWR	+5V _{DC} power ($\pm 10\%$)
V _{CC} (B)	N/A	24	PWR	
V _{CCA} (A)	13	28	PWR	+5 to +12V _{DC} power or +5 to +15V _{DC} power ($\pm 5\%$)
V _{CCA} (B)	N/A	19	PWR	
V _{EE} (A)	19	32	PWR	-12 or -15V _{DC} power ($\pm 5\%$) Recommended de-coupling capacitors 4.7 μ F and 1 μ F
V _{EE} (B)	N/A	23	PWR	
GND (A)	3, 9, 18	3, 7, 31	GND	Ground reference
GND (B)	N/A	12, 16, 22	GND	

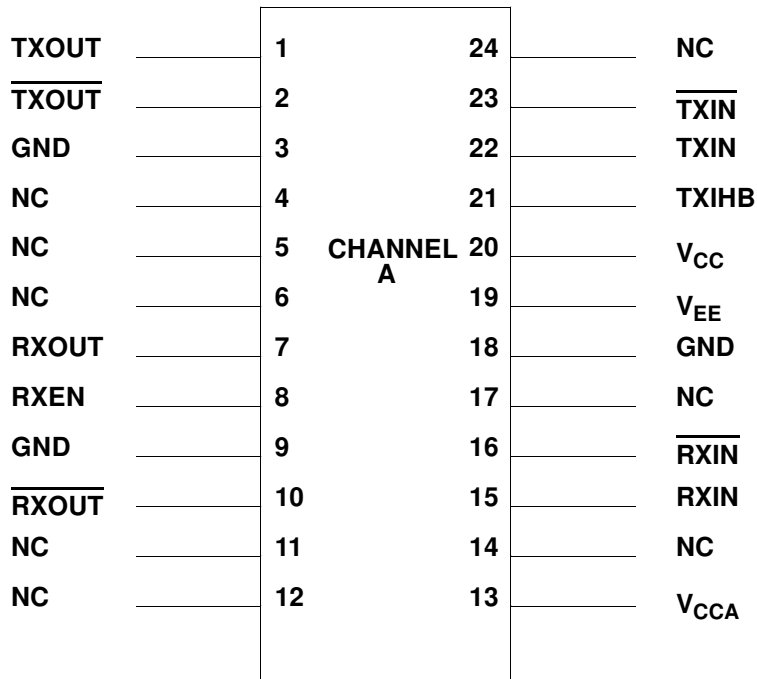

Figure 2a. Functional Pin Diagram--Single Channel

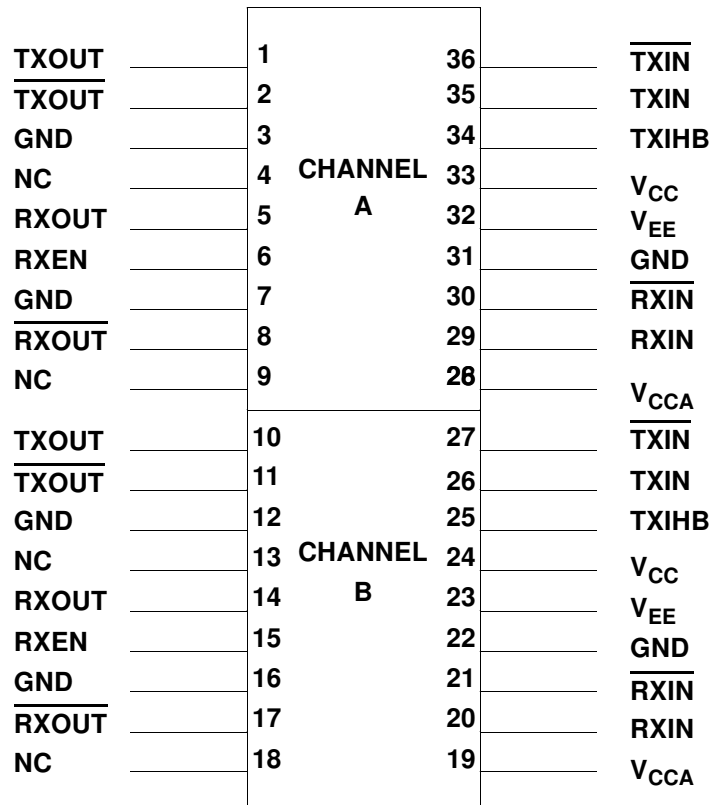

Figure 2b. Functional Pin Diagram--Dual Channel

TRANSMITTER

The transmitter section accepts Manchester II biphasе TTL data and converts this data into differential phase-modulated current drive. Transmitter current drivers are coupled to a MIL-STD-1553 data bus via a transformer driven from the TXOUT and $\overline{\text{TXOUT}}$ terminals. Transmitter output terminals' non-transmitting state is enabled by asserting TXIHB (logic 1), or by placing both TXIN and $\overline{\text{TXIN}}$ at the same logic level. Table 1, Transmit Operating Mode, lists the functions for the output data in reference to the state of TXIHB. Figure 3 shows typical transmitter waveforms.

RECEIVER

The receiver section accepts biphasе differential data from a MIL-STD-1553 data bus at its RXIN and $\overline{\text{RXIN}}$ inputs. The receiver converts input data to biphasе Manchester II TTL format and is available for decoding at the RXOUT and $\overline{\text{RXOUT}}$ terminals. The outputs RXOUT and $\overline{\text{RXOUT}}$ represent positive and negative excursions (respectively) of the inputs RXIN and $\overline{\text{RXIN}}$. Figure 4 shows typical receiver output waveforms.

Models UT63M105, UT63M107, UT63M125, and UT63M127 idle in the "0" state when disabled or receiving no signal.

POWER SUPPLY VOLTAGES

The UT63M1XX series meets device requirements over a wide range of power supply voltages. Table 2 shows the overall capabilities of all available devices. Each channel of the dual transceiver is electrically and physically separate from the other and fully independent, including all power and signal lines. Thus there will be no interaction between the channels.

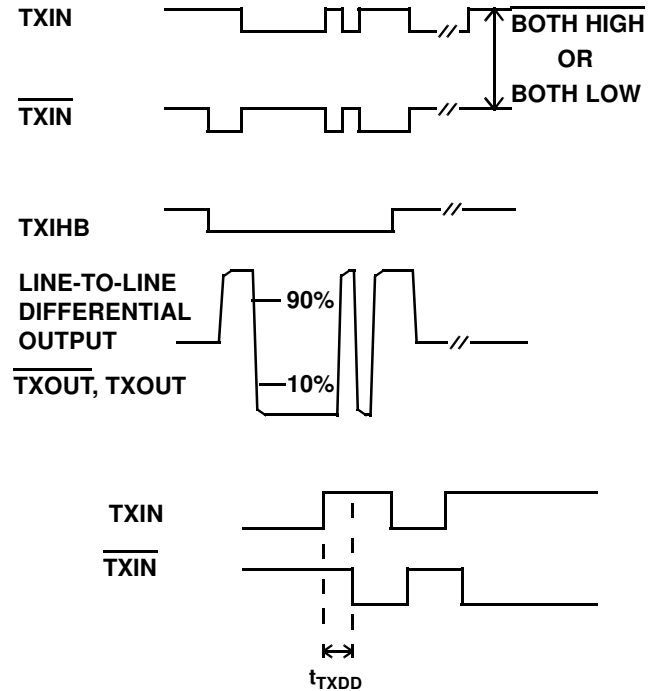

Figure 3. Typical Transmitter Waveforms

Table 1. Transmit Operating Mode

TXIN	$\overline{\text{TXIN}}$	TXIHB	TXOUT
x ¹	x	1	Off ²
0	0	x	Off ³
0	1	0	On
1	0	0	On
1	1	x	Off ³

Notes:

1. x = Don't care.
2. Transmitter output terminals are in the non-transmitting mode during Off time.
3. Transmitter output terminals are in the non-transmitting mode during Off time, independent of TXIHB status.

DATA BUS INTERFACE

The designer can connect the UT63M1XX to the data bus via a short-stub (direct-coupling) connection or a long-stub (transformer-coupling) connection. Use a short-stub connection when the distance from the isolation transformer to the data bus does not exceed a one-foot maximum. Use a long-stub connection when the distance from the isolation transformer exceeds the one-foot maximum and is less than twenty-five feet. Figure 5 shows various examples of bus coupling configurations. The UT63M1XX series transceivers are designed to function with MIL-STD-1553A and 1553B compatible transformers.

RECOMMENDED THERMAL PROTECTION

All packages, single and dual, should mount to or contact a heat removal rail located in the printed circuit board. To insure proper heat transfer between the package and the heat removal rail, use a thermally conductive material between the package and the heat removal rail. Use a material such as Mereco XLN-589 or equivalent to insure heat transfer between the package and heat removal rail.

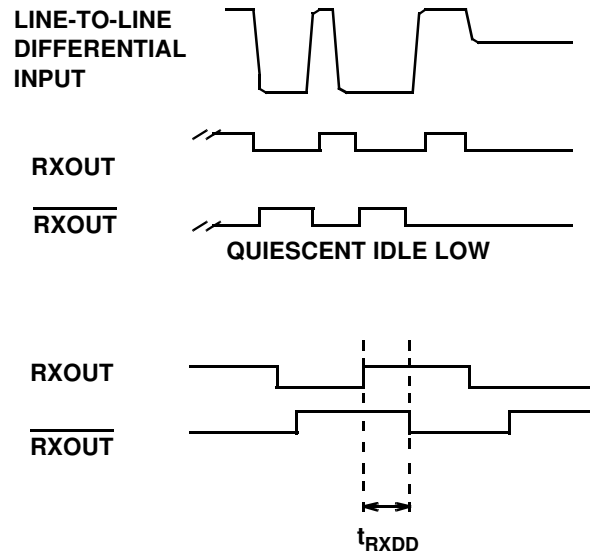
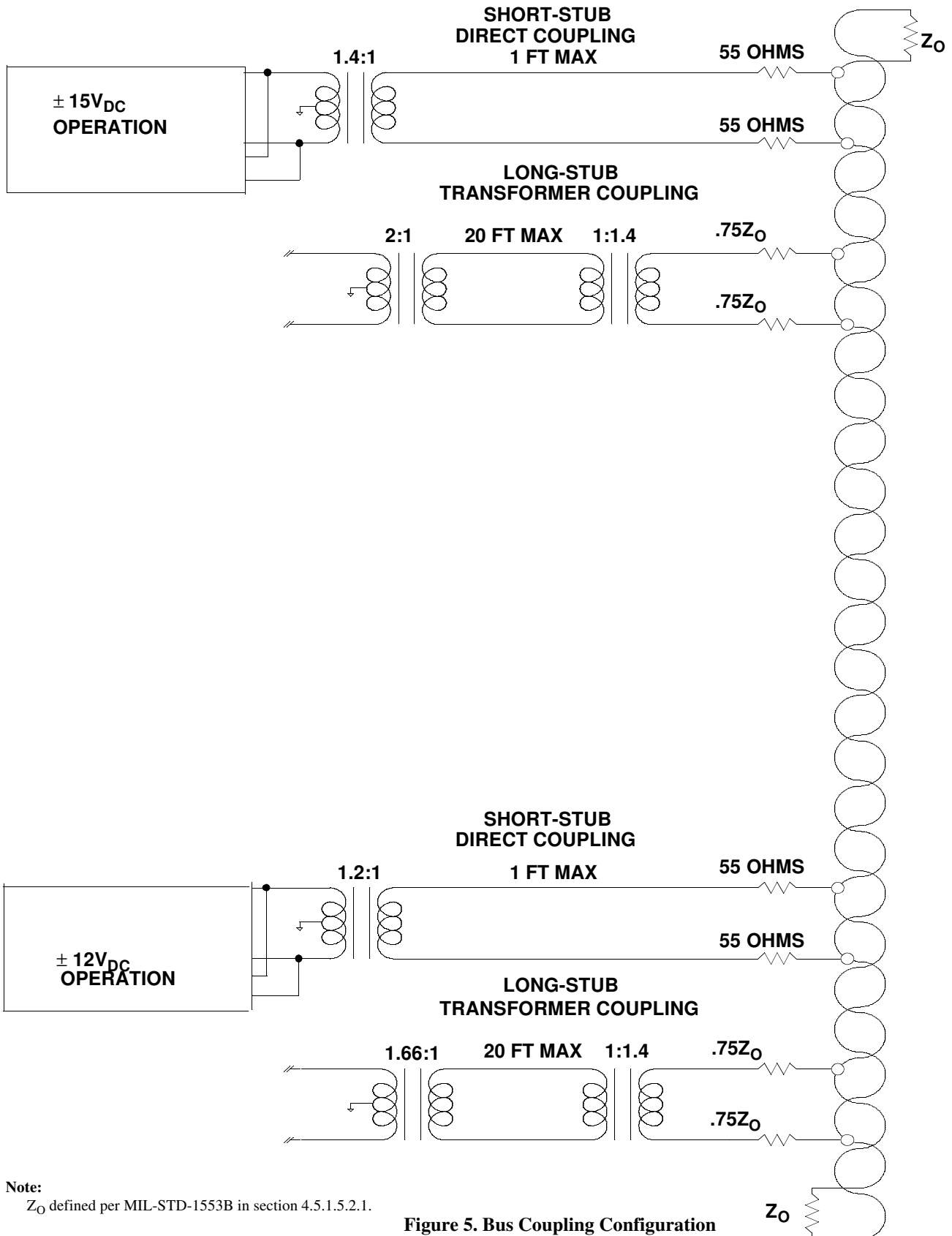

Figure 4. Typical Receiver Waveforms

Table 2. Transceiver Model Capabilities

MODEL	V _{CC}	V _{EE}	V _{CCA}	IDLE
UT63M105	+5V	-15V	+5 to +15V	Low
UT63M107	+5V	-12V	+5 to +12V	Low
UT63M125	+5V	-15V	+5 to +15V	Low
UT63M127	+5V	-12V	+5 to +12V	Low



Note:
 Z₀ defined per MIL-STD-1553B in section 4.5.1.5.2.1.

Figure 5. Bus Coupling Configuration

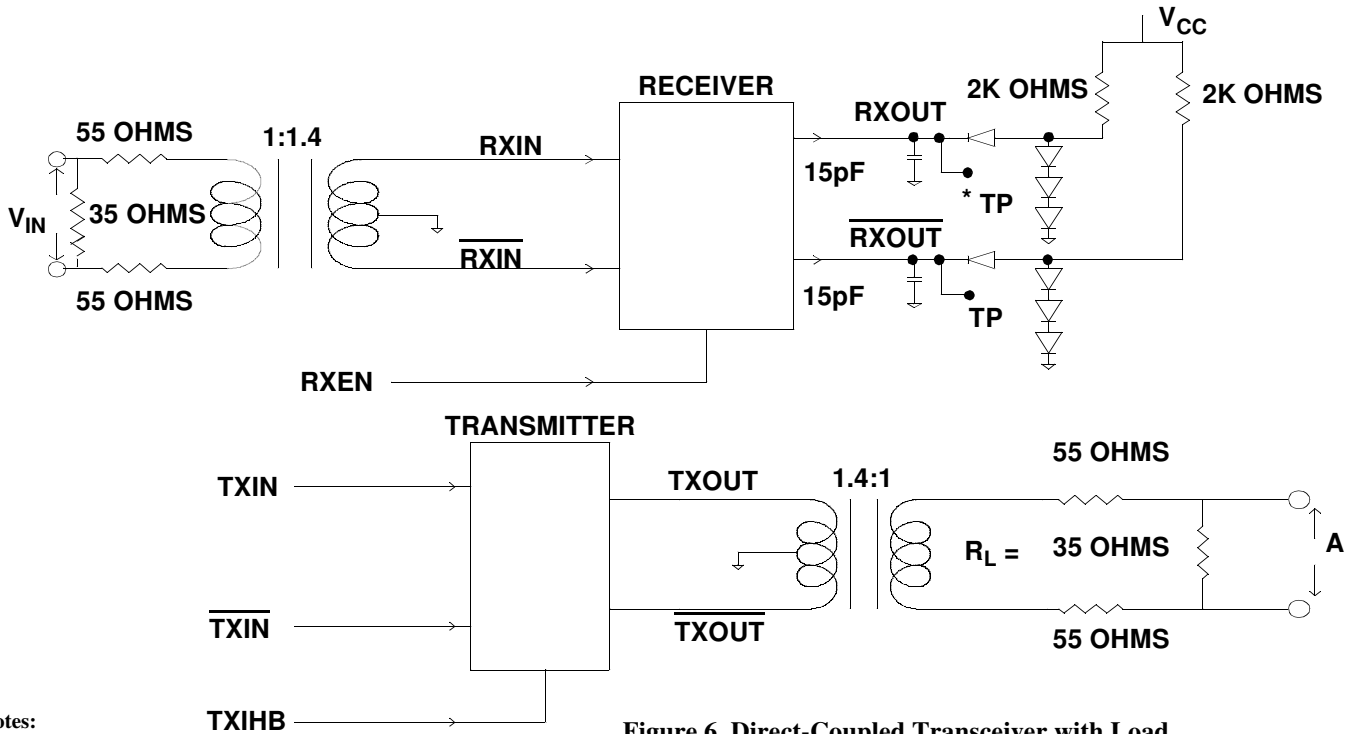

Figure 6. Direct-Coupled Transceiver with Load

Notes:

1. TP = Test point.
2. R_L removed for terminal input impedance test.
3. TX and RX tied together.

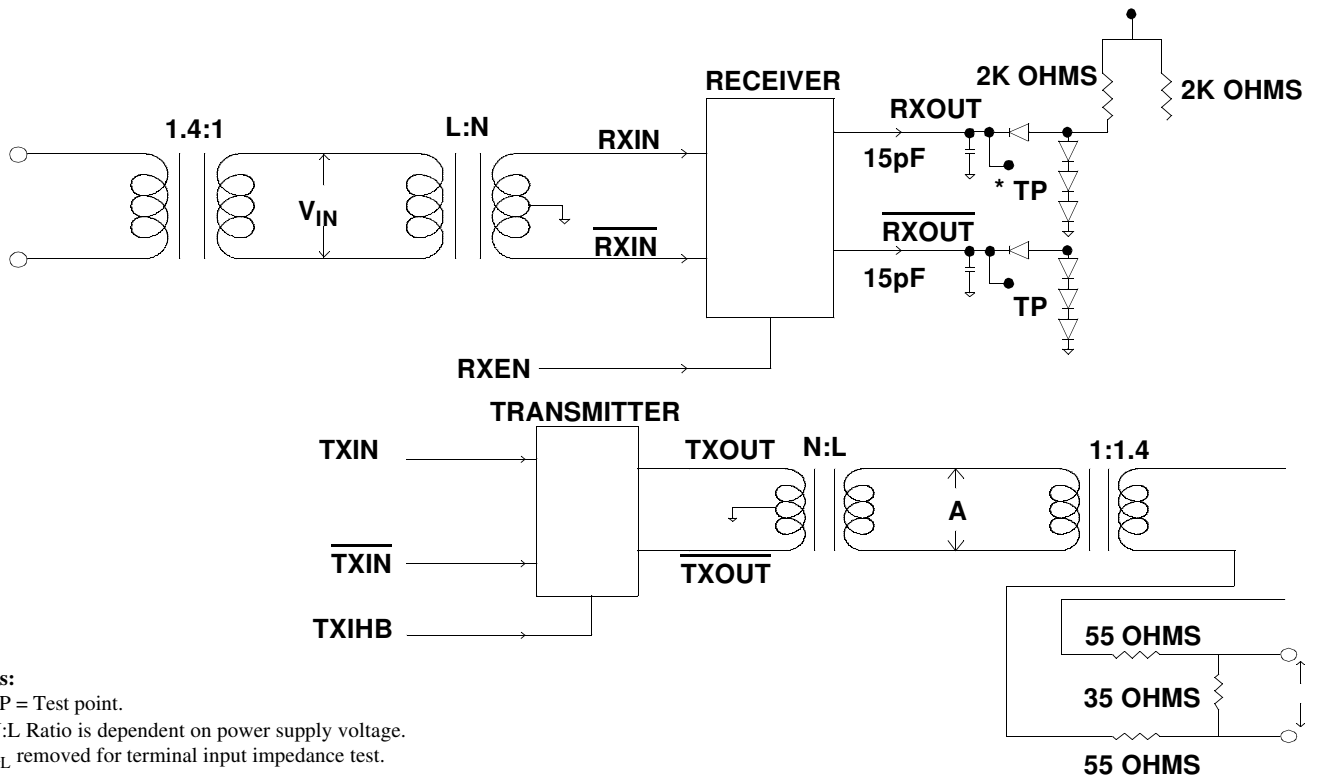
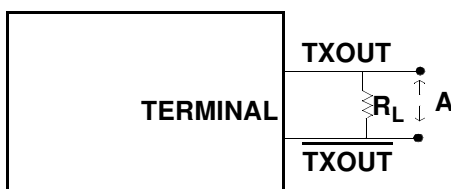

Figure 7. Transformer-Coupled Transceiver with Load

Notes:

1. TP = Test point.
2. N:L Ratio is dependent on power supply voltage.
3. R_L removed for terminal input impedance test.
4. TX and RX tied together.



Notes:

Transformer-Coupled Stub:

Terminal is defined as transceiver plus isolation transformer. Point A defined in figure 7.

Direct-Coupled Stub:

Terminal is defined as transceiver plus isolation transformer and fault resistors. Point A defined in figure 6.

Figure 8. Transceiver Test Circuit MIL-STD-1553B

ABSOLUTE MAXIMUM RATINGS¹

(Referenced to V_{SS})

SYMBOL	PARAMETER	LIMITS	UNIT
V_{CC}	Supply Voltage	7.0	V
V_{EE}	Supply Voltage	-22	V
V_{CCA}	Supply Voltage	+22	V
V_{IN}	Input Voltage Range (Receiver)	42	V_{PP} , L-L
V_{IN}	Logic Input Voltage	-0.3 to +5.5	V
I_O	Output Current (Transmitter)	190	mA
P_D	Power Dissipation (per Channel)	4	W
Q_{JC}	Thermal Impedance, Junction-to-Case	6 ²	°C/W
T_J	Operating Temperature, Junction	-55 to +150	°C
T_C	Operating Temperature, Case	-55 to +125	°C
T_{STG}	Storage Temperature	-65 to +150	°C

Notes:

1. Stress outside the listed absolute maximum rating may cause permanent damage to the devices. This is a stress rating only, and functional operation of the device at these or any other conditions beyond limits indicated in the operational sections of this specification is not recommended. Exposure to absolute maximum rating conditions for extended periods may affect device reliability.
2. Mounting per MIL-STD-883, Method 1012.

RECOMMENDED OPERATING CONDITIONS

PARAMETER	LIMITS	UNIT
Logic input voltage range	0 to +5.0	V
Receiver differential voltage	9.0	V_{P-P}
Driver peak output current	180	mA
Serial data rate	0.1 to 1	MHz
Case operating temperature range (T_C)	-55 to +125	°C

DC ELECTRICAL CHARACTERISTICS

$V_{CC} = +5V (\pm 10\%)$

$V_{CCA} = +5V \text{ to } +12V (\pm 5\%) \text{ or } +5V \text{ to } +15V (\pm 5\%)$

$V_{EE} = -12V \text{ or } -15V (\pm 5\%)$

$-55^{\circ}C < T_C < +125^{\circ}C$

SYMBOL	PARAMETER	MINIMUM	MAXIMUM	UNIT	CONDITION
V_{IL}	Input Low Voltage		0.8	V	RXEN, TXIHB, TXIN, $\overline{\text{TXIN}}$
V_{IH}	Input High Voltage	2.0		V	RXEN, TXIHB, TXIN, $\overline{\text{TXIN}}$
I_{IL}	Input Low Current	-1.6		mA	$V_{IL} = 0.4V$; RXEN, TXIHB, TXIN, $\overline{\text{TXIN}}$
I_{IH}	Input High Current		40	μA	$V_{IL} = 2.4V$; RXEN, TXIHB, TXIN, $\overline{\text{TXIN}}$
V_{OL}	Output Low Voltage		0.55	V	$I_{OL} = 4.0 \text{ mA}$; RXOUT, $\overline{\text{RXOUT}}$
V_{OH}	Output High Voltage	2.4		V	$I_{OH} = 0.4 \text{ mA}$; RXOUT, $\overline{\text{RXOUT}}$
I_{CC}	V_{CC} Supply Current		60 60 60	mA mA mA	$V_{EE} = -12V$ $V_{CC} = 5V$ $V_{CCA} = +5V \text{ to } +12V$ 0% duty cycle (non-transmitting) 50% duty cycle ($f = 1\text{MHz}$) 100% duty cycle ($f = 1\text{MHz}$)
			60 60 60	mA mA mA	$V_{EE} = -15V$ $V_{CC} = 5V$ $V_{CCA} = +5V \text{ to } +15V$ 0% duty cycle (non-transmitting) 50% duty cycle ($f = 1\text{MHz}$) 100% duty cycle ($f = 1\text{MHz}$)
I_{CCA}	V_{CCA} Supply Current		10 10 10	mA mA mA	$V_{EE} = -12V$ $V_{CC} = 5V$ $V_{CCA} = +5V \text{ to } +12V$ 0% duty cycle (non-transmitting) 50% duty cycle ($f = 1\text{MHz}$) 100% duty cycle ($f = 1\text{MHz}$)
			10 10 10	mA mA mA	$V_{EE} = -15V$ $V_{CC} = 5V$ $V_{CCA} = +5V \text{ to } +15V$ 0% duty cycle (non-transmitting) 50% duty cycle ($f = 1\text{MHz}$) 100% duty cycle ($f = 1\text{MHz}$)
I_{EE}	V_{EE} Supply Current		40 140 230	mA mA mA	$V_{EE} = -12V$ $V_{CC} = 5V$ $V_{CCA} = +5V \text{ to } +12V$ 0% duty cycle (non-transmitting) 50% duty cycle ($f = 1\text{MHz}$) 100% duty cycle ($f = 1\text{MHz}$)
			40 130 230	mA mA mA	$V_{EE} = -15V$ $V_{CC} = 5V$ $V_{CCA} = +5V \text{ to } +15V$ 0% duty cycle (non-transmitting) 50% duty cycle ($f = 1\text{MHz}$) 100% duty cycle ($f = 1\text{MHz}$)

DC ELECTRICAL CHARACTERISTICS¹

$V_{CC} = +5V (\pm 10\%)$

$V_{CCA} = +5V \text{ to } +12V (\pm 5\%)$ or $+5V \text{ to } +15V (\pm 5\%)$ ²

$V_{EE} = -12V \text{ or } -15V (\pm 5\%)$ ²

$-55^{\circ}\text{C} < T_C < +125^{\circ}\text{C}$

SYMBOL	PARAMETER	MINIMUM	MAXIMUM	UNIT	CONDITION	
P_{CD}	Power Dissipation				$V_{EE} = -12V$ $V_{CC} = 5V$	
				0.9	W	$V_{CCA} = +5V \text{ to } +12V$
				2.1	W	0% duty cycle (non-transmitting)
				3.3	W	50% duty cycle ($f = 1\text{MHz}$)
						100% duty cycle ($f = 1\text{MHz}$)
			1.0	W	$V_{CCA} = +5V \text{ to } +15V$	
			2.5	W	0% duty cycle (non-transmitting)	
			3.8	W	50% duty cycle ($f = 1\text{MHz}$)	
					100% duty cycle ($f = 1\text{MHz}$)	

Notes:

1. All tests guaranteed per test figure 6.
2. As specified in test conditions.

RECEIVER ELECTRICAL CHARACTERISTICS ¹

$V_{CC} = +5V (\pm 10\%)$

$V_{CCA} = +5V \text{ to } +12V (\pm 5\%) \text{ or } +5V \text{ to } +15V (\pm 5\%)$

$V_{EE} = -12V \text{ or } -15V (\pm 5\%)$

$-55^{\circ}C < T_C < +125^{\circ}C$

SYMBOL	PARAMETER	MINIMUM	MAXIMUM	UNIT	CONDITION
R_{IZ}^2	Differential (Receiver) Input Impedance	15		K Ohms	Input $f = 1\text{MHz}$ (no transformer in circuit)
C_{IN}^2	Input Capacitance		10	pF	RXEN; input $f = 1\text{MHz}$ @ 0V
V_{IC}^2	Common Mode Input Voltage	-10	+10	V	Direct-coupled stub: input $1.2V_{PP}$, 200ns rise/fall time $\pm 25\text{ns}$, $f = 1\text{MHz}$.
V_{TH}	Input Threshold Voltage (No Response) ²		0.20	$V_{PP,L-L}$	Transformer-coupled stub: input at $f = 1\text{MHz}$, rise/fall time 200ns at (Receiver output 0 \rightarrow 1 transition).
	Input Threshold Voltage (No Response)		0.28	$V_{PP,L-L}$	Direct-coupled stub: input at $f = 1\text{MHz}$, rise/fall time 200ns at (Receiver output 0 \rightarrow 1 transition).
	Input Threshold Voltage (Response) ²	0.86	14.0	$V_{PP,L-L}$	Transformer-coupled stub: input at $f = 1\text{MHz}$, rise/fall time 200ns output at (Receiver output 0 \rightarrow 1 transition).
	Input Threshold Voltage (Response)	1.20	20.0^2	$V_{PP,L-L}$	Direct-coupled stub: input at $f = 1\text{MHz}$, rise/fall time 200ns output at (Receiver output 0 \rightarrow 1 transition).
$CMMR^2$	Common Mode Rejection Ratio	Pass/Fail ³		N/A	

Notes:

1. All tests guaranteed per test figure 6.

2. Guaranteed by device characterization.

3. Pass/fail criteria per the test method described in MIL-HDBK-1553 Appendix A, RT Validation Test Plan, Section 5.1.2.2, Common Mode Rejection.

TRANSMITTER ELECTRICAL CHARACTERISTICS¹

$V_{CC} = +5V (\pm 10\%)$

$V_{CCA} = +5V \text{ to } +12V (\pm 5\%) \text{ or } +5V \text{ to } +15V (\pm 5\%)$

$V_{EE} = -12V \text{ or } -15V (\pm 5\%)$

$-55^\circ\text{C} < T_C < +125^\circ\text{C}$

SYMBOL	PARAMETER	MINIMUM	MAXIMUM	UNIT	CONITION
V_O	Output Voltage Swing per MIL-STD-1553B ² (See figure 9)	18	27	$V_{PP, L-L}$	Transformer-coupled stub, Figure 8, Point A: input $f = 1\text{MHz}$, $R_L = 70 \text{ ohms}$.
	per MIL-STD-1553B (See figure 9)	6	9	$V_{PP, L-L}$	Direct-coupled stub, Figure 8, Point A: input $f = 1\text{MHz}$, $R_L = 35 \text{ ohms}$.
	per MIL-STD-1553A ² (See figure 9)	6	20	$V_{PP, L-L}$	Figure 7, Point A: input $f = 1\text{MHz}$, $R_L = 35 \text{ ohms}$.
V_{NS}^2	Output Noise Voltage Differential (See figure 9)		14	mV-RMS, L-L	Transformer-coupled stub, Figure 8, Point A: input $f = \text{DC to } 10\text{MHz}$, $R_L = 70 \text{ ohms}$.
			5	mV-RMS, L-L	Direct-coupled stub, Figure 8, Point A: input $f = \text{DC to } 10\text{MHz}$, $R_L = 35 \text{ ohms}$.
V_{OS}^2	Output Symmetry (See figure 9)	-250	+250	mV _{PP, L-L}	Transformer-coupled stub, Figure 8, Point A: $R_L = 70 \text{ ohms}$, measurement taken $2.5\mu\text{s}$ after end of transmission
		-90	+90	mV _{PP, L-L}	Direct-coupled stub, Figure 8, Point A: $R_L = 35 \text{ ohms}$, measurement taken $2.5\mu\text{s}$ after end of transmission
V_{DIS}^2	Output voltage distortion (overshoot or ring) (See figure 9)	-900	+900	mV peak, L-L	Transformer-coupled stub, Figure 8, Point A: $R_L = 70 \text{ ohms}$.
		-300	+300	mV peak, L-L	Direct-coupled stub, Figure 8, Point A: $R_L = 35 \text{ ohms}$.
C_{IN}^2	Input Capacitance		10	pF	TXIHB, TXIN, TXIN; input $f = 1\text{MHz @ } 0 \text{ V}$
T_{IZ}^2	Terminal Input Impedance	1		Kohm	Transformer-coupled stub, Figure 7, Point A: input $f = 75\text{KHz to } 1\text{MHz}$ (power on or power off: non-transmitting, R_L removed from circuit).
		2		Kohm	Direct-coupled stub, Figure 6, Point A: input $f = 75\text{KHz to } 1\text{MHz}$ (power on or power off: non-transmitting, R_L removed from circuit).

Notes:

1. All tests guaranteed per test figure 6.
2. Guaranteed by device characterization.

AC ELECTRICAL CHARACTERISTICS ¹

$V_{CC} = +5V (\pm 10\%)$

$V_{CCA} = +5V \text{ to } +12V (\pm 5\%) \text{ or } +5V \text{ to } +15V (\pm 5\%)$

$V_{EE} = -12V \text{ or } -15V (\pm 5\%)$

$-55^{\circ}\text{C} < T_C < +125^{\circ}\text{C}$

SYMBOL	PARAMETER	MINIMUM	MAXIMUM	UNIT	CONDITION
t_R, t_F	Transmitter Output Rise/Fall Time (See figure 10)	100	300	ns	Input $f = 1\text{MHz}$ 50% duty cycle: direct-coupled $R_L = 35 \text{ ohms}$ output at 10% through 90% points $\overline{\text{TXOUT}}$, TXOUT . Figure 3.
t_{RXDD}	RXOUT Delay	-200	+200	ns	RXOUT to $\overline{\text{RXOUT}}$; Figure 4.
t_{TXDD}^3	TXIN Skew	-25	+25	ns	TXIN to $\overline{\text{TXIN}}$; Figure 4.
t_{RZCD}	Zero Crossing	-150	+150	ns	Direct-coupled stub; input $f = 1\text{MHz}$, $3V_{PP}$ (skew $\text{INPUT} \pm 150\text{ns}$), rise/fall time 200ns.
t_{TZCS}^2	Zero Crossing Stability (See figure 10)	-25	+25	ns	Input TXIN and $\overline{\text{TXIN}}$ should create transmitter output zero crossings at 500ns, 1000ns, 1500ns, and 2000ns. These zero crossings should not deviate more than $\pm 25\text{ns}$.
$t_{DXOFF}^{3,4}$	Transmitter Off; Delay from Inhibit Active		400	ns	TXIN and $\overline{\text{TXIN}}$ toggling @ 1MHz; TXIHB transitions from logic zero to one.
$t_{DXON}^{3,5}$	Transmitter On; Delay from Inhibit Inactive		250	ns	TXIN and $\overline{\text{TXIN}}$ toggling @ 1MHz; TXIHB transitions from logic one to zero.

Notes:

1. All tests guaranteed per test figure 6.
2. Guaranteed by device characterization.
3. Supplied as a design limit but not guaranteed or tested.
4. Delay time from transmit inhibit (1.5V) to transmit off (280mV).
5. Delay time from not transmit inhibit (1.5V) to transmit on (1.2V).

Table 3. Transformer Requirements Versus Power Supplies

COUPLING TECHNIQUE	$\pm 12V_{DC}$	$\pm 15V_{DC}$
DIRECT-COUPLED: Isolation Transformer Ratio	1.2:1	1.4:1
TRANSFORMER-COUPLED: Isolation Transformer Ratio	1.66:1	2:1
Coupling Transformer Ratio	1:1.4	1:1.4

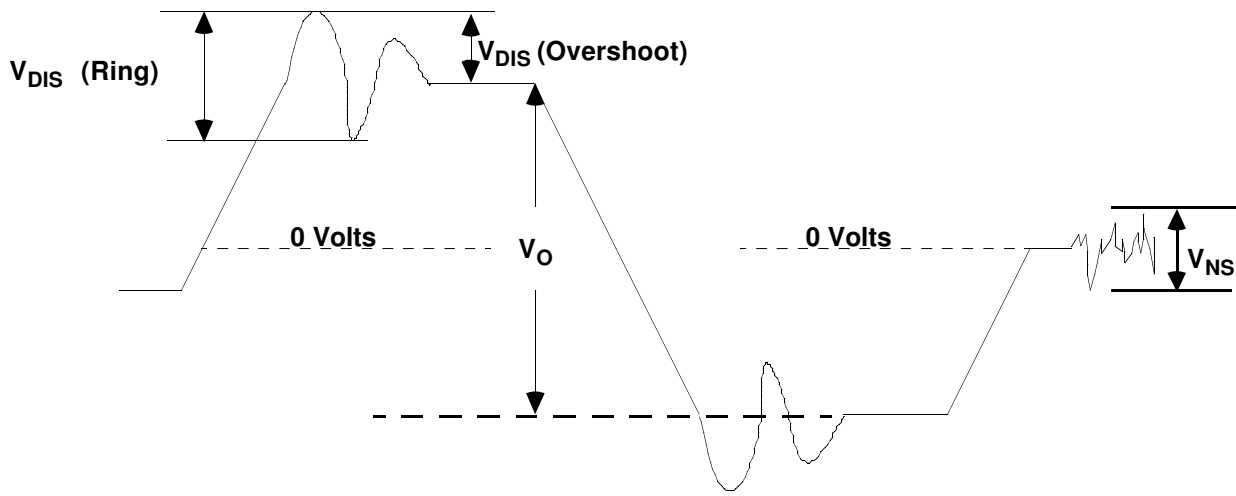

Figure 9. Transmitter Output Characteristics (V_{DIS} , V_{NS} , V_O)

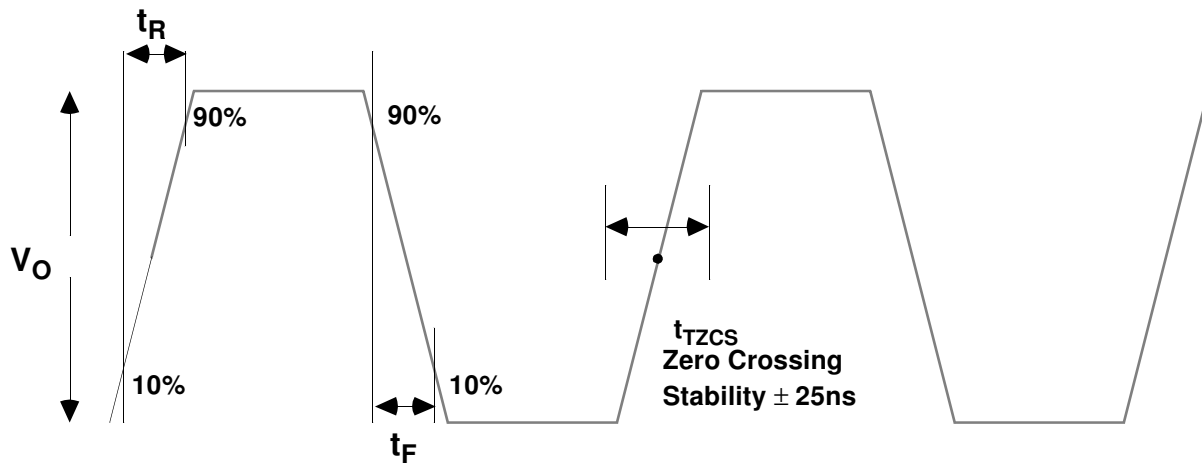

Figure 10. Transmitter Output Zero Crossing Stability (t_{TZCS} , t_R , t_F)

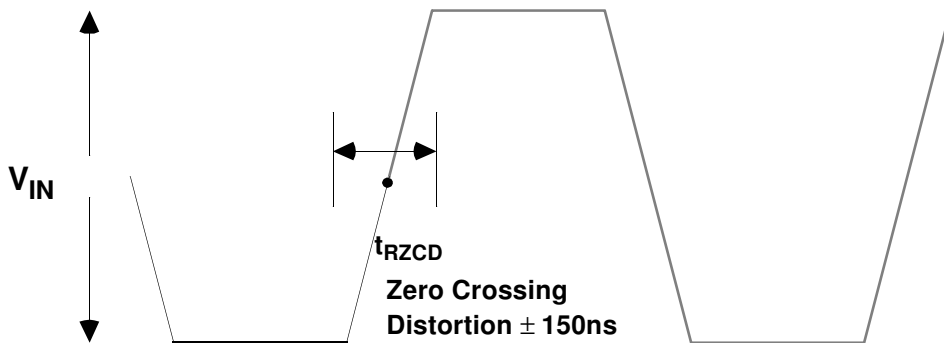
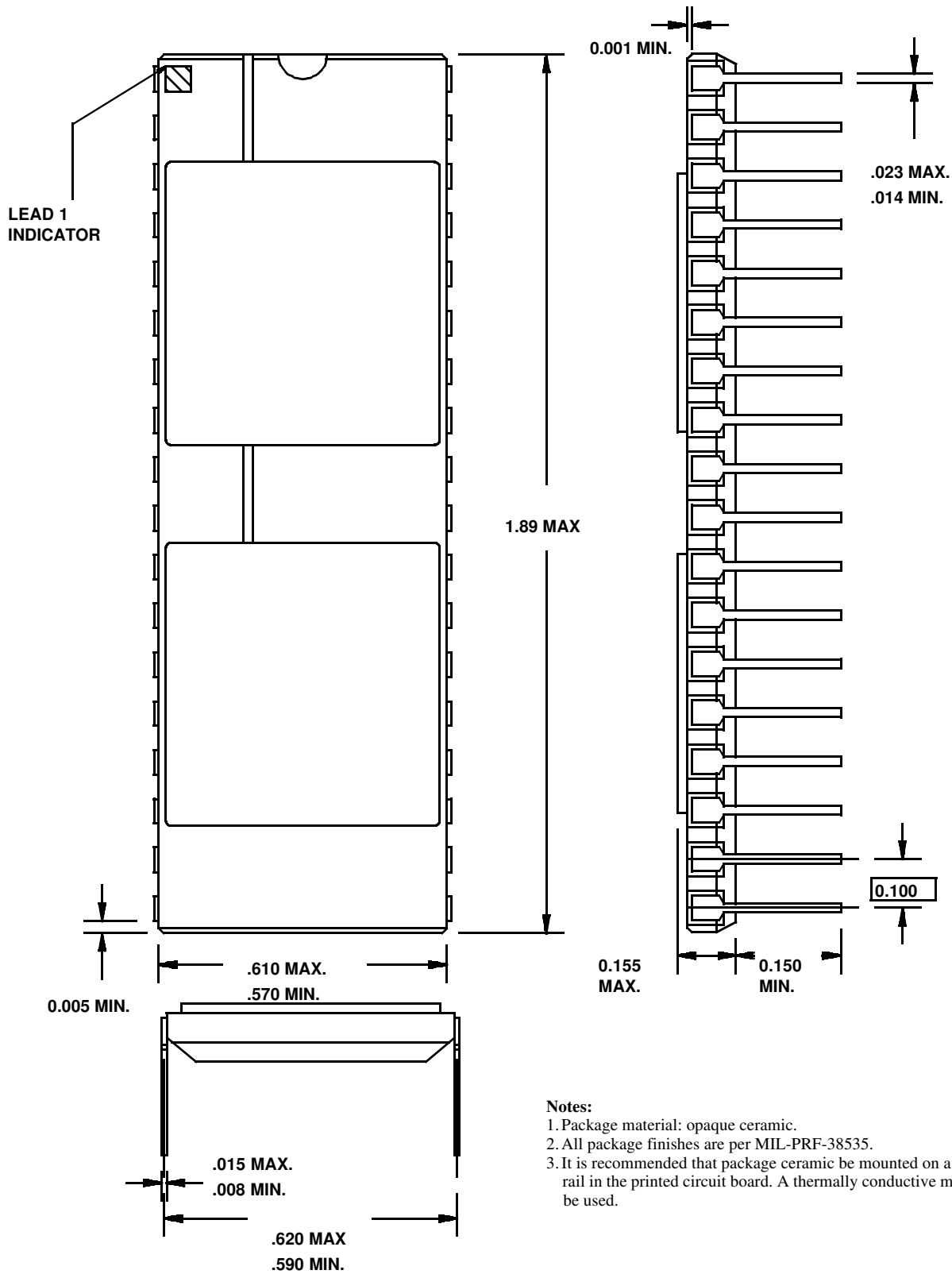

Figure 11. Receiver Input Zero Crossing Distortion (t_{RZCD})



(AT SEATING PLANE)

Figure 12. 36-Pin Side-Brazed DIP, Dual Cavity

Notes:

1. Package material: opaque ceramic.
2. All package finishes are per MIL-PRF-38535.
3. It is recommended that package ceramic be mounted on a heat removal rail in the printed circuit board. A thermally conductive material should be used.

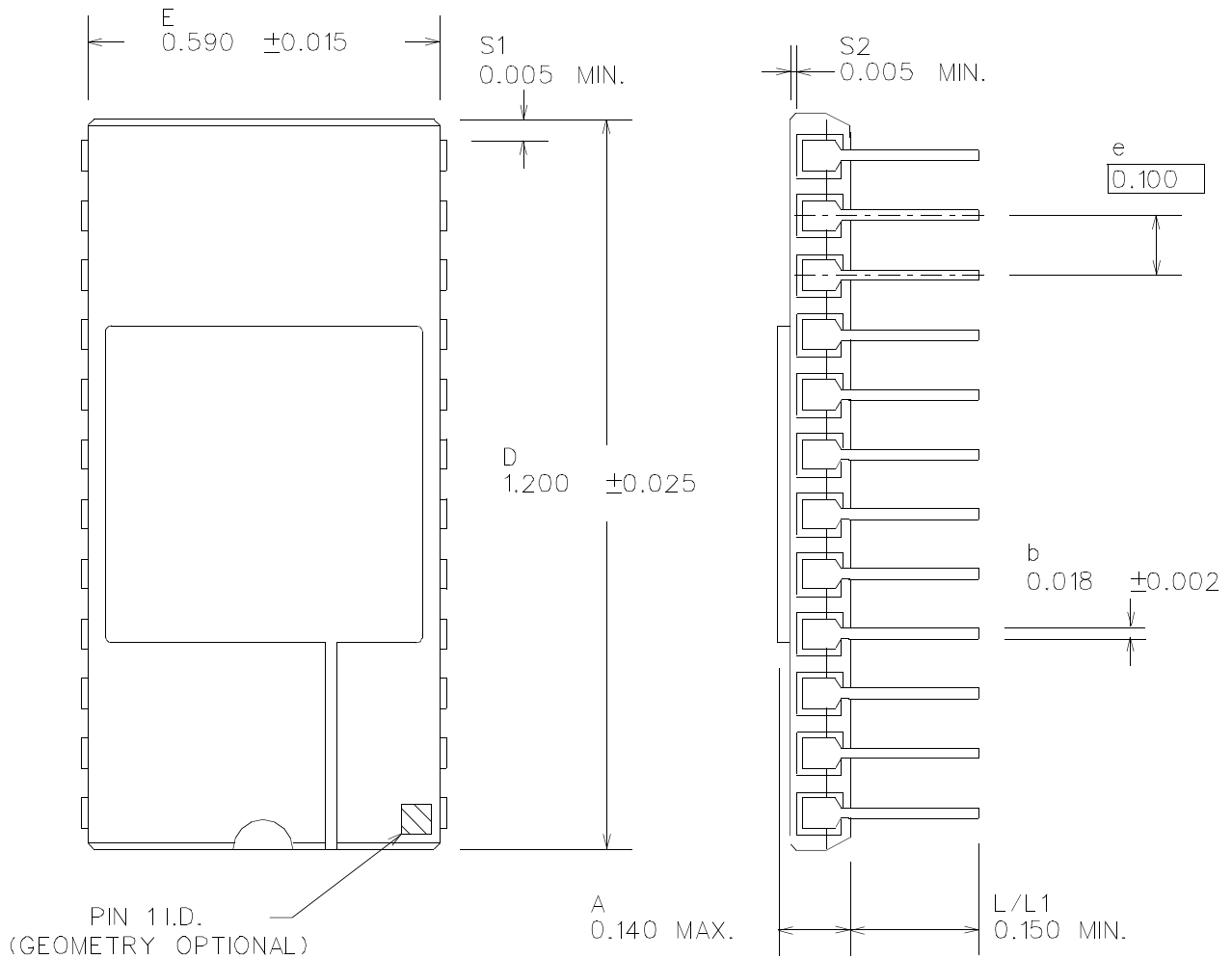

TOP VIEW

SIDE VIEW

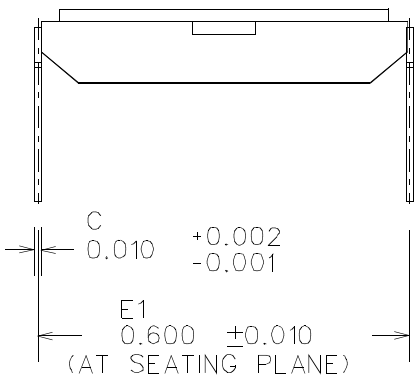

END VIEW

Notes:

1. All package finishes are per MIL-M-38510.
2. It is recommended that package ceramic be mounted on a heat removal rail in the printed circuit board. A thermally conductive material such as MEREKO XLN-589 or equivalent should be used.
3. Letter designations are for cross-reference to MIL-M-38510.

Figure 13. 24-Pin Side-Brazed DIP, Single Cavity

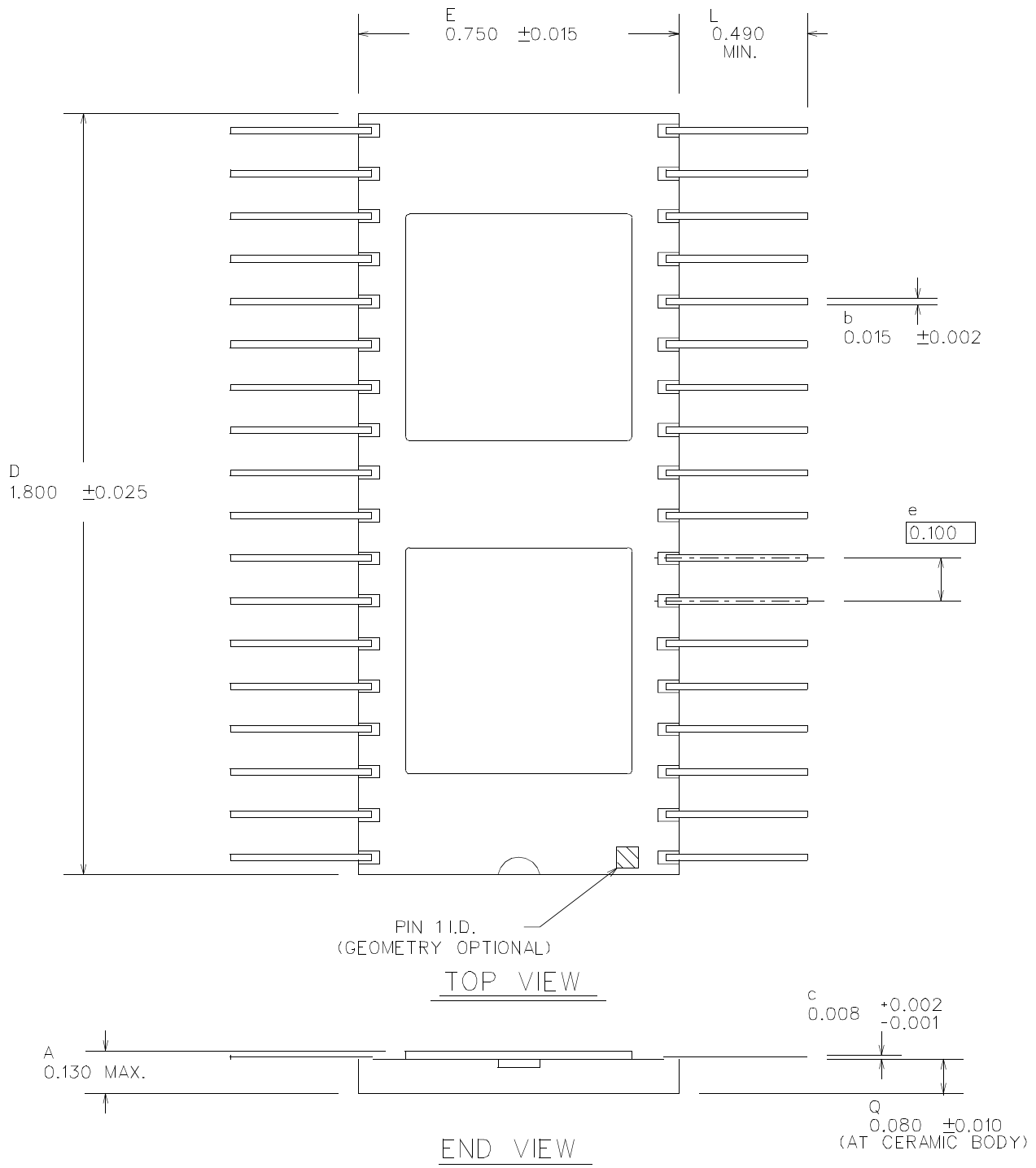

Notes:

1. All package finishes are per MIL-M-38510.
2. It is recommended that package ceramic be mounted on a heat removal rail in the printed circuit board. A thermally conductive material such as MEREKO XLN-589 or equivalent should be used.
3. Letter designations are for cross-reference to MIL-M-38510.

**Figure 14. 36-Pin Lead Flatpack
(100-MIL Lead Spacing)**

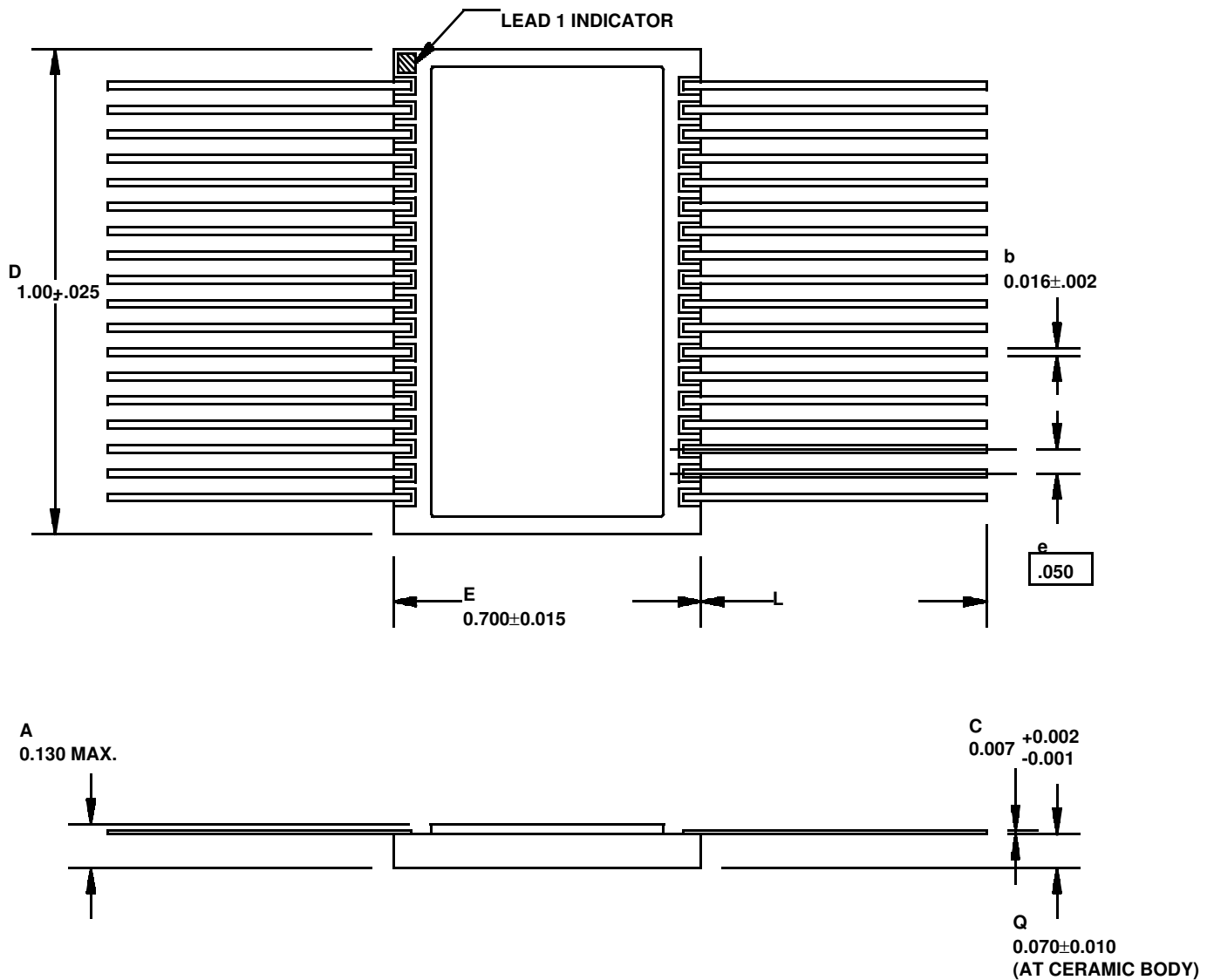

Notes:

1. Package material: opaque ceramic.
2. All package plating finishes are per MIL-M-38510.
3. Lid is not connected to any electrical potential.
4. It is recommended that package ceramic be mounted to a heat removal rail located in the printed circuit board. A thermally conductive material such as Mereco XLN-589 or equivalent should be used.

**Figure 15. 36-Lead Flatpack, Dual Cavity
(50-Mil Lead Spacing)**

ORDERING INFORMATION

UT63M Single Channel MIL-STD-1553 Monolithic Transceiver: SM

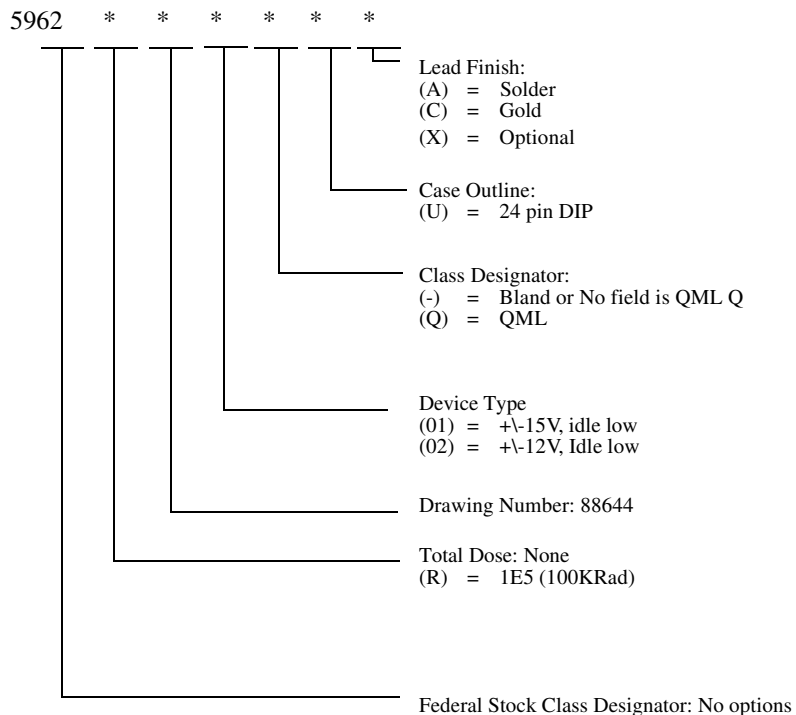

Notes:

1. Lead finish (A, C, or X) must be specified.
2. If an "X" is specified when ordering, part marking will match the lead finish and will be either "A" (solder) or "C" (gold).
3. RadHard offered only on 01 device type. Cobalt 60testing required.
4. For QML Q product, the Q designator is intentionally left blank in the SMD number (e.g. 5962-8864401UX).

UT63M Single Channel MIL-STD-1553 Monolithic Transceiver

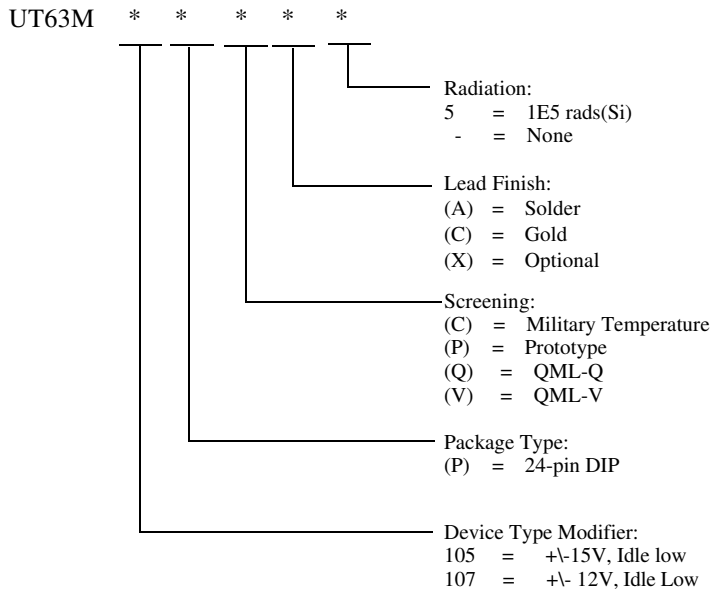

Notes:

1. Lead finish (A, C, or X) must be specified.
2. If an "X" is specified when ordering, part marking will match the lead finish and will be either "A" (solder) or "C" (gold).
3. Military Temperature range devices are burned-in and are tested at -55°C, room temperature, and 125°C. Radiation characteristics are neither tested nor guaranteed and may not be specified.
4. Devices have prototype assembly and are tested at 25°C only. Radiation characteristics are neither tested nor guaranteed and may not be specified. Lead finish is at UTMC's option and an "X" must be specified when ordering.
5. The 63M105 only may be ordered with 1E5 rads(Si) total dose. Co60 testing is required. Contact factory for details.
6. SEU and neutron irradiation limits will be added when available.

ORDERING INFORMATION

UT63M Dual Monolithic Transceiver: SMD

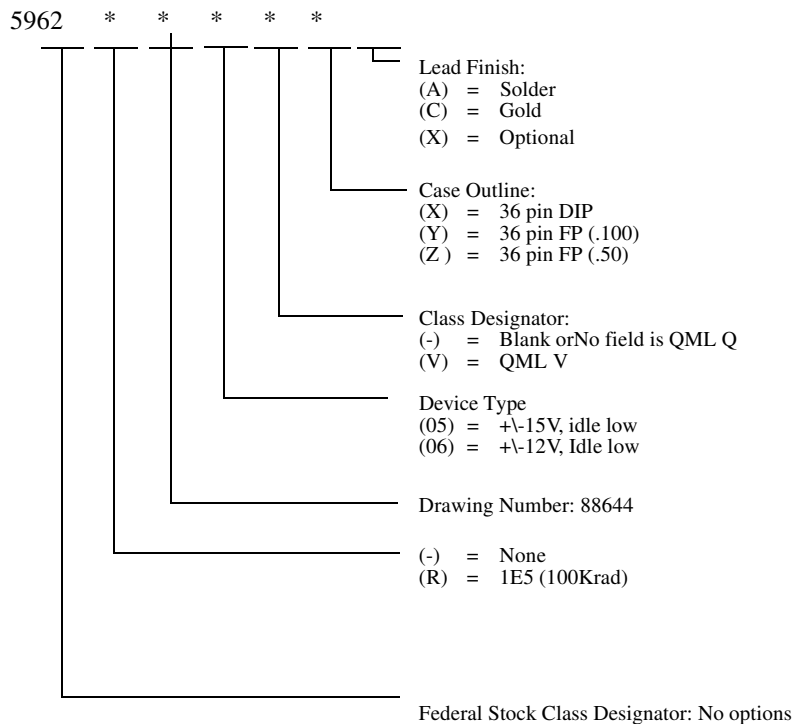

Notes:

1. Lead finish (A, C, or X) must be specified.
2. If an "X" is specified when ordering, part marking will match the lead finish and will be either "A" (solder) or "C" (gold).
3. RadHard offered only on 05 device type. Cobalt 60testing required.
4. For QML Q product, the Q designator is intentionally left blank in the SMD number (e.g. 5962-8864405YX).

UT63M Dual Multichip Monolithic Transceiver

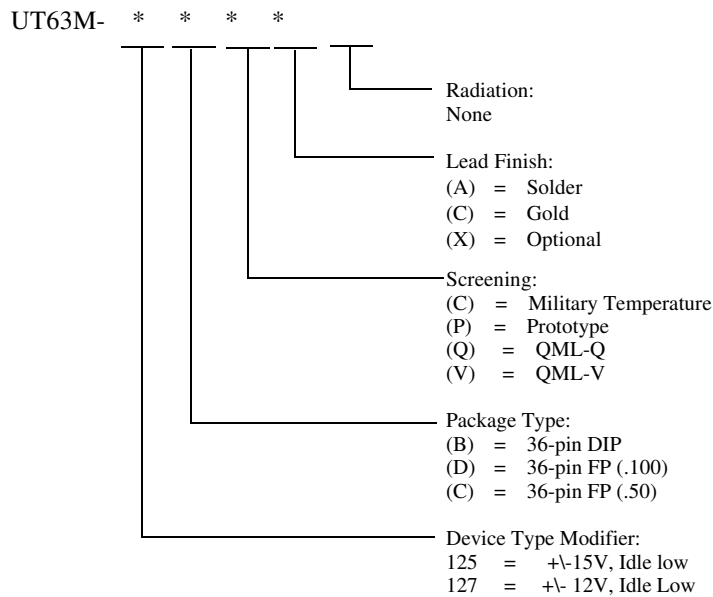

Notes:

1. Lead finish (A, C, or X) must be specified.
2. If an "X" is specified when ordering, part marking will match the lead finish and will be either "A" (solder) or "C" (gold).
3. Military Temperature range devices are burned-in and tested at -55°C, room temperature, and 125°C. Radiation characteristics are neither tested nor guaranteed and may not be specified.
4. Devices have prototype assembly and are tested at 25°C only. Radiation characteristics are neither tested nor guaranteed and may not be specified. Lead finish is GOLD only.

Aeroflex Colorado Springs - Datasheet Definition

Advanced Datasheet - Product In Development

Preliminary Datasheet - Shipping Prototype

Datasheet - Shipping QML & Reduced Hi-Rel

COLORADO

Toll Free: 800-645-8862
Fax: 719-594-8468

INTERNATIONAL

Tel: 805-778-9229
Fax: 805-778-1980

NORTHEAST

Tel: 603-888-3975
Fax: 603-888-4585

SE AND MID-ATLANTIC

Tel: 321-951-4164
Fax: 321-951-4254

WEST COAST

Tel: 949-362-2260
Fax: 949-362-2266

CENTRAL

Tel: 719-594-8017
Fax: 719-594-8468

www.aeroflex.com/RadHard
info-ams@aeroflex.com

Aeroflex Colorado Springs, Inc. (Aeroflex) reserves the right to make changes to any products and services herein at any time without notice. Consult Aeroflex or an authorized sales representative to verify that the information in this data sheet is current before using this product. Aeroflex does not assume any responsibility or liability arising out of the application or use of any product or service described herein, except as expressly agreed to in writing by Aeroflex; nor does the purchase, lease, or use of a product or service from Aeroflex convey a license under any patent rights, copyrights, trademark rights, or any other of the intellectual rights of Aeroflex or of third parties.



Our passion for performance is defined by three attributes represented by these three icons: solution-minded, performance-driven and customer-focused