



FEATURES

- Single power supply operation (3.3V to 5.0V) or dual power supply operation (± 1.65 to $\pm 2.5V$)
- Radiation performance
 - Total dose: $>1\text{Mrad(Si)}$; Dose rate = 50 - 300 rads(Si)/s
 - ELDRS Immune
 - SEL Immune $>100\text{ MeV-cm}^2/\text{mg}$
 - Neutron Displacement Damage $>10^{14}\text{ neutrons/cm}^2$
- Rail-to-Rail input and output range
- Short Circuit Tolerant
- Full military temperature range
- Designed for aerospace and high reliability space applications
- Packaging – Hermetic ceramic SOIC
 - 16-pin, .411"L x .293"W x .090"Ht
 - Weight - 0.8 grams max
- **Aeroflex Plainview's Radiation Hardness Assurance Plan is DLA Certified to MIL-PRF-38534, Appendix G.**

GENERAL DESCRIPTION

Aeroflex's RHD5900 is a radiation hardened, single supply, quad operational amplifier in a 16-pin SOIC package. The RHD5900 design uses specific circuit topology and layout methods to mitigate total ionizing dose effects and single event latchup. These characteristics make the RHD5900 especially suited for the harsh environment encountered in Deep Space missions. It is guaranteed operational from -55°C to $+125^{\circ}\text{C}$. Available screened in accordance with MIL-PRF-38534 Class K, the RHD5900 is ideal for demanding military and space applications.

ORGANIZATION AND APPLICATION

The RHD5900 amplifiers are capable of rail-to-rail input and outputs. Performance characteristics listed are for general purpose operational 5V CMOS amplifier applications. The amplifiers will drive substantial resistive or capacitive loads and are unity gain stable under normal conditions. Resistive loads in the low kohm range can be handled without gain derating and capacitive loads of several nF can be tolerated. CMOS device drive has a negative temperature coefficient and the devices are therefore inherently tolerant to momentary shorts, although on chip thermal shutdown is not provided. All inputs and outputs are diode protected.

The devices will not latch with SEU events to above $100\text{ MeV-cm}^2/\text{mg}$. Total dose degradation is minimal to above 1Mrad(Si) . Displacement damage environments to neutron fluence equivalents in the mid 10^{14} neutrons per cm^2 range are readily tolerated. There is no sensitivity to low-dose rate (ELDRS) effects. SEU effects are application dependant.

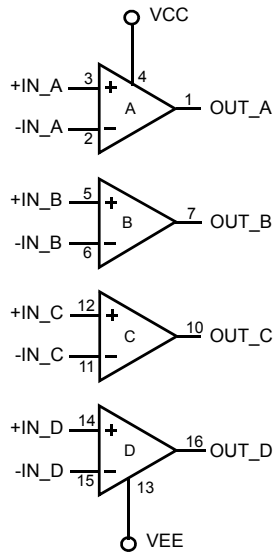

FIGURE 1: BLOCK DIAGRAM

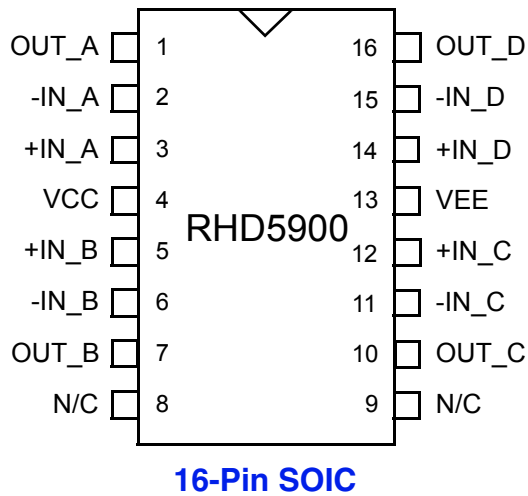

FIGURE 2: PACKAGE PIN-OUT

Notes:

1. Package and lid are electrically isolated from signal pads.
2. It is recommended that N/C or no connect pins (pins 8 and 9) and lid be grounded. This eliminates or minimizes any ESD or static buildup.

ABSOLUTE MAXIMUM RATINGS

Parameter	Range	Units
Case Operating Temperature Range	-55 to +125	°C
Storage Temperature Range	-65 to +150	°C
Junction Temperature	+150	°C
Supply Voltage V _{CC} - V _{EE}	+6.0	V
Input Voltage	V _{CC} +0.4 V _{EE} -0.4	V
Lead Temperature (soldering, 10 seconds)	300	°C
Thermal Resistance, Junction to Case, θ_{jc}	7	°C/W
ESD Rating	2.0	KV
Power @25°C	200	mW

NOTICE: Stresses above those listed under "Absolute Maximums Rating" may cause permanent damage to the device. These are stress rating only; functional operation beyond the "Operation Conditions" is not recommended and extended exposure beyond the "Operation Conditions" may affect device reliability.

RECOMMENDED OPERATING CONDITIONS

Symbol	Parameter	Typical	Units
+V _{CC}	Power Supply Voltage	3.3 to 5.0	V
V _{CM}	Input Common Mode Range	V _{CC} to V _{EE}	V

ELECTRICAL PERFORMANCE CHARACTERISTICS

(T_C = -55°C TO +125°C, +V_{CC} = +5.0V -- UNLESS OTHERWISE SPECIFIED)

Parameter	Symbol	Conditions	Min	Typ	Max	Units
Input Offset Voltage	V _{OS}		-2		2	mV
Input Offset Current	I _{OS}	T _C = +25°C, -55°C	-100		100	pA
		T _C = +125°C	-500		500	
Input Bias Current	I _B	T _C = +25°C, -55°C	-100		100	pA
		T _C = +125°C	-1000		1000	
Input Offset TempCo <u>2/</u>	V _I OST				10	uV/C
Common Mode Rejection Ratio	CMRR		70			dB
Power Supply Rejection Ratio	PSRR		70			dB
Output Voltage High	V _{OH}	R _{OUT} =3.6K to GND, T _C =+25°C, -55°C	4.9			V
		R _{OUT} =3.6K to GND, T _C =+125°C	4.8			
Output Voltage Low	V _{OL}	R _{OUT} =3.6K to V _{CC} , T _C =+25°C, -55°C			0.1	V
		R _{OUT} =3.6K to V _{CC} , T _C =+125°C			0.125	
Short Circuit Output Current <u>2/</u>	I _O (SINK)	V _{OUT} to V _{CC}	-63			mA
	I _O (SOURCE)	V _{OUT} to V _{EE}			45	mA
Slew Rate	SR	R _L = 8K, Gain = 1	2.5			V/uS
Open Loop Gain <u>2/</u>	A _{OL}	No Load	90			dB
Unity Gain Bandwidth <u>2/</u>	U _{GBW}	R _L = 10K	4	6.5		MHz
Quiescent Supply Current	I _{CCQ}	No Load			5.5	mA
Channel Separation <u>2/</u>		R _L = 2K, f = 1.0KHz	90			dB
Input-Referred Voltage Noise <u>2/</u>	e _n	F = 5 kHz		15		nV/ $\sqrt{\text{Hz}}$
Phase Margin <u>2/</u>	Φ_m		30			Deg

Notes:

1/ Specification derated to reflect Total Dose exposure to 1 Mrad(Si) @ +25°C.

2/ Not Tested. Shall be guaranteed by design, characterization, or correlation to other test parameters.

RHD5900 QUAD OPERATIONAL AMPLIFIER APPLICATION NOTES

APPLICATION NOTE 1: DUAL POWER SUPPLY AMPLIFIER

Inverting Amplifier

$$V_{OUT} = -V_{IN} \left(\frac{R_2}{R_1} \right)$$

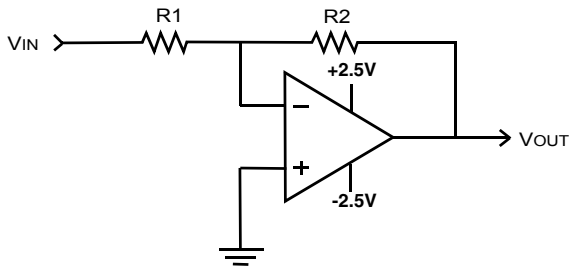

Non Inverting Amplifier

$$V_{OUT} = V_{IN} \left(1 + \frac{R_2}{R_1} \right)$$

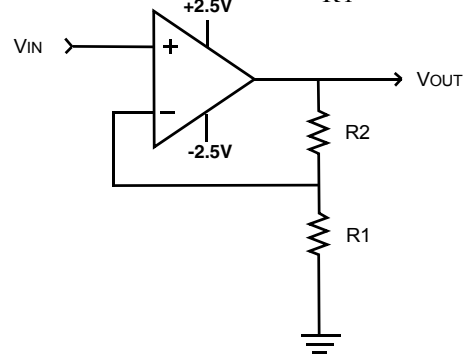

APPLICATION NOTE 2: SINGLE POWER SUPPLY AMPLIFIER

Inverting Amplifier

$$V_{OUT} = -V_{IN} \left(\frac{R_2}{R_1} \right)$$

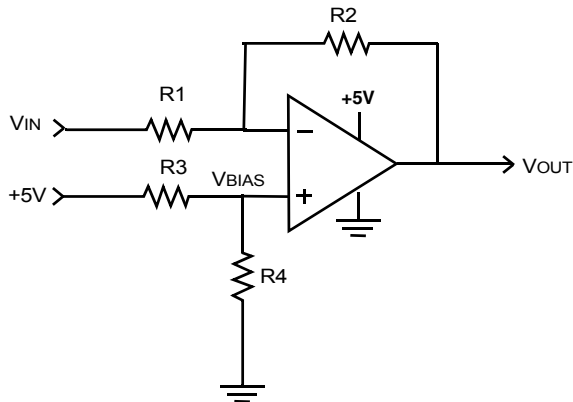

Non Inverting Amplifier

$$V_{OUT} = V_{IN} \left(1 + \frac{R_2}{R_1} \right)$$

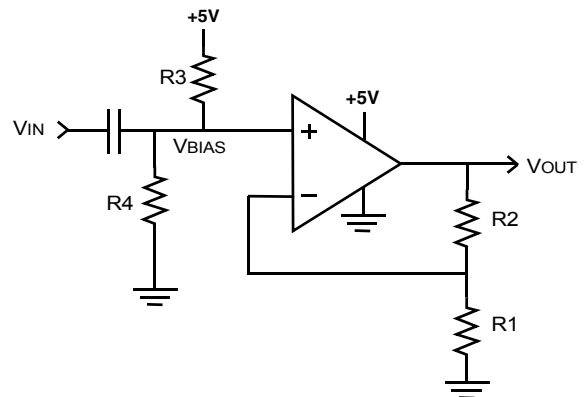

Note: For V_{OUT} DC @ mid range of common mode voltage range, $V_{BIAS} = 2.5 / (1 + R_2/R_1)$, $V_{BIAS} = +5 * R_4 / (R_3 + R_4)$

APPLICATION NOTE 3: DIFFERENTIAL INPUT AMPLIFIER

Differential Input Amplifier

$$V_{OUT} = \left(V_2 \left(\frac{R_4}{R_3 + R_4} \right) \left(1 + \frac{R_2}{R_1} \right) \right) - \left(V_1 \frac{R_2}{R_1} \right)$$

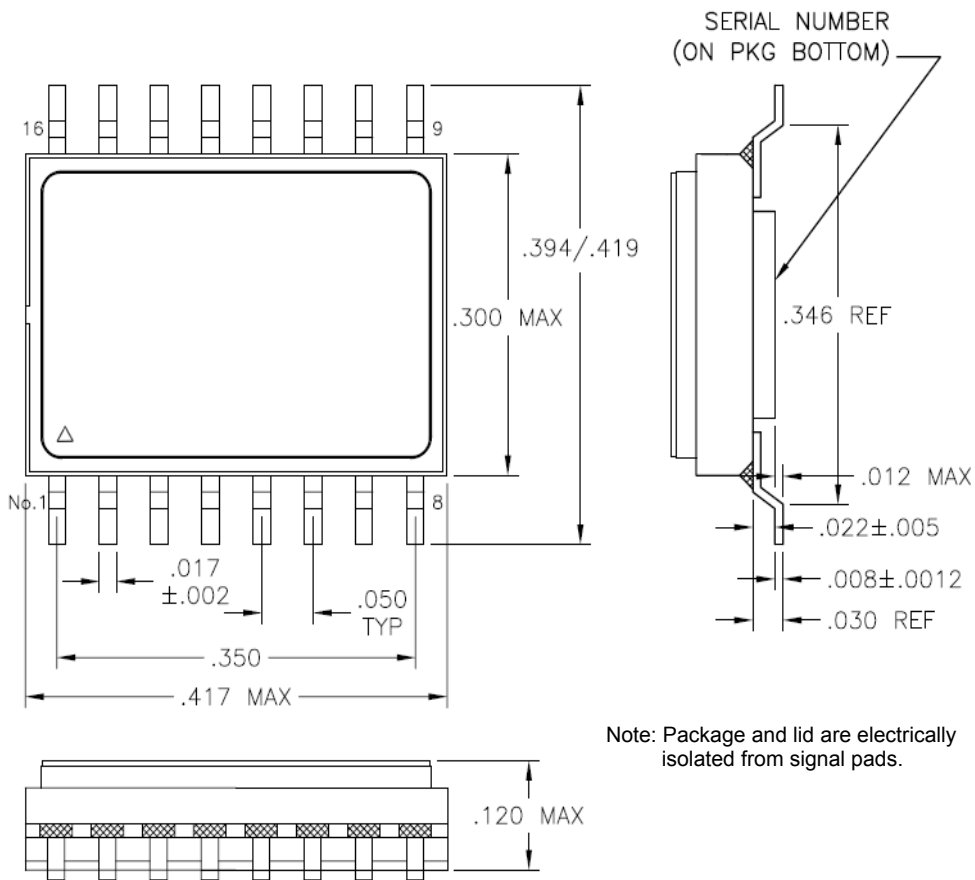
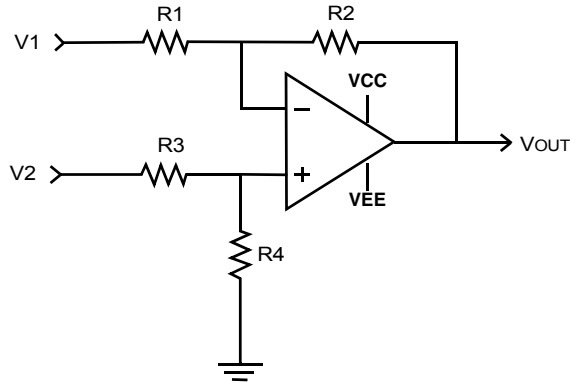

FIGURE 3: PACKAGE OUTLINE

ORDERING INFORMATION

Model	DLA SMD #	Screening	Package
RHD5900-7	-	Commercial Flow, +25°C testing only	16-pin SOIC Package
RHD5900-S	-	Military Temperature, -55°C to +125°C Screened in accordance with the individual Test Methods of MIL-STD-883 for Space Applications	
RHD5900-201-1S	5962-1024101KXC	DLA SMD Pending	
RHD5900-201-2S	5962-1024101KXA		
RHD5900-901-1S	5962H1024101KXC	DLA SMD and Radiation Certification Pending	
RHD5900-901-2S	5962H1024101KXA		

EXPORT CONTROL:

This product is controlled for export under the International Traffic in Arms Regulations (ITAR). A license from the U.S. Department of State is required prior to the export of this product from the United States.

EXPORT WARNING:

Aeroflex's military and space products are controlled for export under the International Traffic in Arms Regulations (ITAR) and may not be sold or proposed or offered for sale to certain countries. (See ITAR 126.1 for complete information.)

PLAINVIEW, NEW YORK

Toll Free: 800-THE-1553
Fax: 516-694-6715

INTERNATIONAL

Tel: 805-778-9229
Fax: 805-778-1980

NORTHEAST

Tel: 603-888-3975
Fax: 603-888-4585

SE AND MID-ATLANTIC

Tel: 321-951-4164
Fax: 321-951-4254

WEST COAST

Tel: 949-362-2260
Fax: 949-362-2266

CENTRAL

Tel: 719-594-8017
Fax: 719-594-8468

www.aeroflex.com info-ams@aeroflex.com



Aeroflex Microelectronic Solutions reserves the right to change at any time without notice the specifications, design, function, or form of its products described herein. All parameters must be validated for each customer's application by engineering. No liability is assumed as a result of use of this product. No patent licenses are implied.



Our passion for performance is defined by three attributes represented by these three icons: solution-minded, performance-driven and customer-focused