

# RadHard-by-Design RHD5911 Quad Comparator Clocked

[www.aeroflex.com/RHDseries](http://www.aeroflex.com/RHDseries)

March 2, 2012

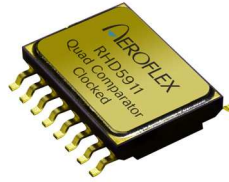

**AEROFLEX**  
A passion for performance.

## FEATURES

- Single power supply operation at 3.3V or 5.0V
- Radiation performance
  - Total dose: >1Mrad(Si); Dose rate = 50 - 300 rads(Si)/s
  - ELDRS Immune
  - SEL Immune >100 MeV-cm<sup>2</sup>/mg
  - Neutron Displacement Damage >10<sup>14</sup> neutrons/cm<sup>2</sup>
- Ultra low power
- Short Circuit Tolerant
- Full military temperature range
- Designed for aerospace and high reliability space applications
- Packaging – Hermetic ceramic SOIC
  - 16-pin, .411"L x .293"W x .090"Ht
  - Weight - 0.8 grams max
- **Aeroflex Plainview's Radiation Hardness Assurance Plan is DLA Certified to MIL-PRF-38534, Appendix G.**

## GENERAL DESCRIPTION

Aeroflex's RHD5911 is a radiation hardened, single supply, quad clocked comparator in a 16-pin SOIC package. The RHD5911 design uses specific circuit topology and layout methods to mitigate total ionizing dose effects and single event latchup. These characteristics make the RHD5911 especially suited for the harsh environment encountered in Deep Space missions. It is guaranteed operational from -55°C to +125°C. Available screened in accordance with MIL-PRF-38534 Class K, the RHD5911 is ideal for demanding military and space applications.

## ORGANIZATION AND APPLICATION

The RHD5911 quad clocked comparator is intended for operation with dynamic signals on either or both inputs. Comparison is 'clocked', that is the circuit functions as a regenerative clocked latch with a digital output. For slow input signals with small input differences the comparators can be expected to respond to small noise signals at the inputs. Feedback hysteresis is the responsibility of the user to avoid 'chattering' on system noise.

The comparators will accept signals from (GND + 0.8V) to VCC. The max clocked frequency is 50MHz. The max clock-to-output delay is 10ns.

CMOS device drives have a negative temperature coefficient and the devices are therefore inherently tolerant to momentary shorts, although on chip thermal shutdown is not provided. All inputs and outputs are diode protected.

The devices will not latch with SEU events above 100 Mev-cm<sup>2</sup>/mg. Total dose degradation is minimal to above 1Mrad(Si). Displacement damage environments to neutron fluence equivalents in the mid 10<sup>14</sup> neutrons per cm<sup>2</sup> range are readily tolerated. There is no sensitivity to low-dose rate (ELDRS) effects. SEU effects are application dependant.

The RHD5911 16-pin clocked comparator allow pairs of comparators to access and hold data until needed.

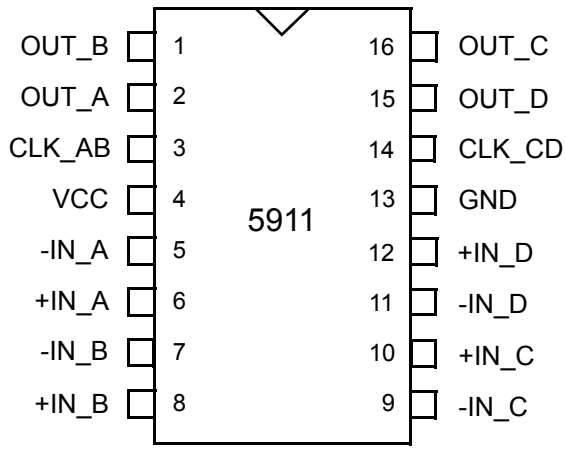

**16-Pin SOIC**

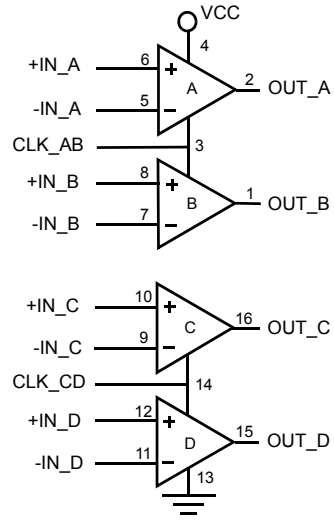

**Notes:**

1. Package and lid are electrically isolated from signal pads.
2. CLK\_AB clocks comparator A & B. CLK\_CD clocks comparator C & D.

**RHD5911: QUAD CLOCKED COMPARATOR**

Power Supply Alarm

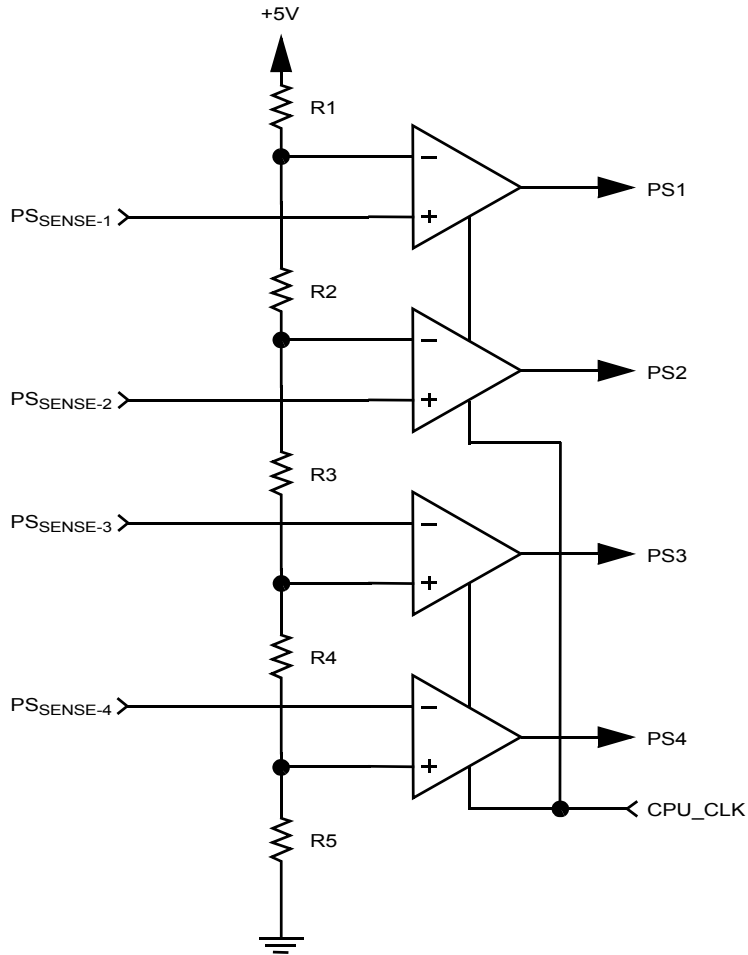

**RHD5911: QUAD CLOCKED COMPARATOR**

## ABSOLUTE MAXIMUM RATINGS

Parameter	Range	Units
Case Operating Temperature Range	-55 to +125	°C
Storage Temperature Range	-65 to +150	°C
Junction Temperature	+150	°C
Supply Voltage +VCC	+6.0	V
Input Voltage	VCC +0.4 GND -0.4	V V
Lead Temperature (soldering, 10 seconds)	300	°C
ESD Rating	2.0	KV
Power @ 25°C	250	mW

NOTICE: Stresses above those listed under "Absolute Maximums Rating" may cause permanent damage to the device. These are stress rating only; functional operation beyond the "Operation Conditions" is not recommended and extended exposure beyond the "Operation Conditions" may affect device reliability.

## RECOMMENDED OPERATING CONDITIONS

Symbol	Parameter	Typical	Units
+VCC	Power Supply Voltage	3.3 to 5.0	V
VCM	Input Common Mode Range	VCC to GND	V

## ELECTRICAL PERFORMANCE CHARACTERISTICS

(TC = -55°C TO +125°C, +VCC = +5.0V -- UNLESS OTHERWISE SPECIFIED)

Parameter	Symbol	Conditions	Min	Typ	Max	Units
Input Offset Voltage <u>1/</u>	VOS		-2		2	mV
Input Offset Current <u>2/</u>	IOS		-1		1	pA
Input Bias Current <u>2/</u>	IB		-2		2	pA
Input Offset TempCo <u>2/</u>	VIOST				10	μV/C
Common Mode Rejection Ratio <u>1/</u>	CMRR		70			dB
Power Supply Rejection Ratio <u>1/</u>	PSRR		70			dB
Output Voltage High <u>1/</u>	VOH	IOUT = 5mA	4.9			V
Output Voltage Low <u>1/</u>	VOL	IOUT = 5mA			0.1	V
Input Voltage - Clock (CLK_AB, CLK_CD) <u>2/</u>	VHI	High	70% VCC			V
Input Voltage - Clock (CLK_AB, CLK_CD) <u>2/</u>	VLO	Low			30% VCC	V
Input Current - Clock (CLK_AB, CLK_CD) <u>2/</u>	ICLK				1	nA
Quiescent Supply Current <u>1/</u>	ICCQ				10	μA

Notes: 1/ Specification derated to reflect Total Dose exposure to 1 Mrad(Si) @ +25°C.

2/ Not Tested. Shall be guaranteed by design, characterization or correlation to other test parameters.

## SWITCHING CHARACTERISTICS

(Tc = -55°C TO +125°C, +VCC = +5.0V -- UNLESS OTHERWISE SPECIFIED)

Parameter	Symbol	Conditions	Min	Max	Units
Input Setup Time	Ts			1	ns
Input Hold Time	TH			5	ns
Output Delay	TD			10	ns
Clock Positive Pulse Width	TWP		100		ns
Clock Frequency	CLK			5	MHz

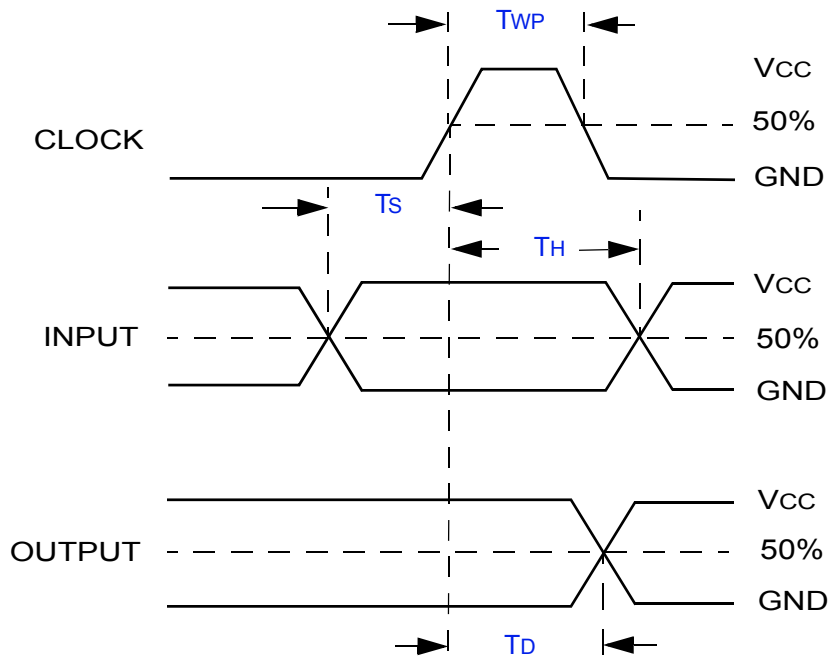

### RHD5911 SWITCHING DIAGRAMS

## ORDERING INFORMATION

Model	DLA SMD #	Screening	Package
RHD5911-7	-	Commercial Flow, +25°C testing only	16-pin SOIC
RHD5911-S	-	Military Temperature, -55°C to +125°C Screened in accordance with the individual Test Methods of MIL-STD-883 for Space Applications	
RHD5911-201-1S	5962-1024202KXC	DLA SMD Pending	
RHD5911-201-2S	5962-1024202KXA		
RHD5911-901-1S	5962H1024202KXC	DLA SMD and Radiation Certification Pending	
RHD5911-901-2S	5962H1024202KXA		

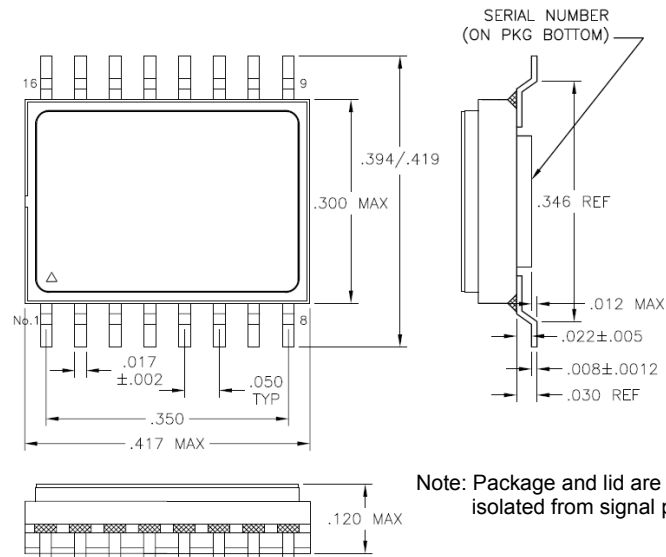

Note: Package and lid are electrically isolated from signal pads.

## PACKAGE OUTLINE

### EXPORT CONTROL:

*This product is controlled for export under the International Traffic in Arms Regulations (ITAR). A license from the U.S. Department of State is required prior to the export of this product from the United States.*

### EXPORT WARNING:

*Aeroflex's military and space products are controlled for export under the International Traffic in Arms Regulations (ITAR) and may not be sold or proposed or offered for sale to certain countries. (See ITAR 126.1 for complete information.)*

**PLAINVIEW, NEW YORK**  
Toll Free: 800-THE-1553  
Fax: 516-694-6715

**INTERNATIONAL**  
Tel: 805-778-9229  
Fax: 805-778-1980

**NORTHEAST**  
Tel: 603-888-3975  
Fax: 603-888-4585

**SE AND MID-ATLANTIC**  
Tel: 321-951-4164  
Fax: 321-951-4254

**WEST COAST**  
Tel: 949-362-2260  
Fax: 949-362-2266

**CENTRAL**  
Tel: 719-594-8017  
Fax: 719-594-8468

[www.aeroflex.com](http://www.aeroflex.com)    [info-ams@aeroflex.com](mailto:info-ams@aeroflex.com)

Aeroflex Microelectronic Solutions reserves the right to change at any time without notice the specifications, design, function, or form of its products described herein. All parameters must be validated for each customer's application by engineering. No liability is assumed as a result of use of this product. No patent licenses are implied.



Our passion for performance is defined by three attributes represented by these three icons: solution-minded, performance-driven and customer-focused

