

Standard Products

# RadHard-by-Design RHD5928 Analog Multiplexer 8-Channel

[www.aeroflex.com/RHDseries](http://www.aeroflex.com/RHDseries)

May 18, 2012

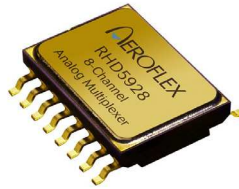

**AEROFLEX**  
A passion for performance.

## FEATURES

- Single power supply operation at 3.3V to 5V
- Radiation performance
  - Total dose: > 1 Mrad(Si); Dose rate = 50 - 300 rads(Si)/s
  - ELDRS Immune
  - SEL Immune > 100 MeV-cm<sup>2</sup>/mg
  - Neutron Displacement Damage > 10<sup>14</sup> neutrons/cm<sup>2</sup>
- Full military temperature range
- Rail to Rail operation
- Low power consumption < 1.0mW
- One address bus (A0-2), and one enable line
- Designed for aerospace and high reliability space applications
- Packaging – Hermetic ceramic SOIC
  - 16-pin, .411"L x .293"W x .090"Ht
  - Weight - 0.8 grams max
- Aeroflex Plainview's Radiation Hardness Assurance Plan is DLA Certified to MIL-PRF-38534, Appendix G.

## GENERAL DESCRIPTION

Aeroflex's RHD5928 is a radiation hardened, single supply, 8 Channel Multiplexer in a 16-pin SOIC package. The RHD5928 design uses specific circuit topology and layout methods to mitigate total ionizing dose effects and single event latchup. These characteristics make the RHD5928 especially suited for the harsh environment encountered in Deep Space missions. It is guaranteed operational from -55°C to +125°C. Available screened in accordance with MIL-PRF-38534 Class K, the RHD5928 is ideal for demanding military and space applications.

## ORGANIZATION AND APPLICATION

The RHD5928 is an 8 to 1 CMOS multiplexer. Channel selection is controlled by 3 bit binary addressing and an active low enable. All inputs and outputs are diode protected.

The devices will not latch with SEU events to above 100 MeV-cm<sup>2</sup>/mg. Total dose degradation is minimal to above 1 Mrad(Si). Displacement damage environments to neutron fluence equivalents in the mid 10<sup>14</sup> neutrons per cm<sup>2</sup> range are readily tolerated. There is no sensitivity to low-dose rate (ELDRS) effects. SEU effects are application dependant.

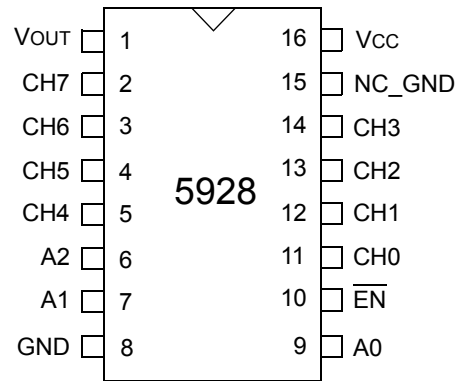
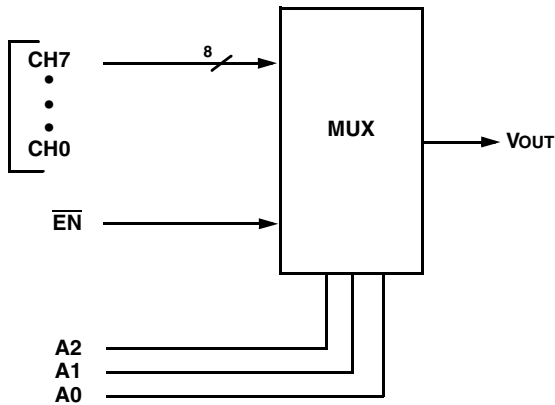

## BLOCK DIAGRAM

## PACKAGE PIN-OUT

### Notes:

1. Package and Lid are electrically isolated from signal pads.
2. It is recommended that the Lid and NC\_GND pin be grounded. This prevents any ESD or static buildup.

Pin	Signal Name	Definition
1	VOUT	Output of Multiplexer.
2	CH7	Analog Input 8
3	CH6	Analog Input 7
4	CH5	Analog Input 6
5	CH4	Analog Input 5
6	A2	Address Bus (MSB)
7	A1	Address Bus
8	GND	DC Supply Return.
9	A0	Address Bus (LSB)
10	$\overline{\text{EN}}$	A Logic High will disable the Multiplexer so that the output is high impedance.
11	CH0	Analog Input 1
12	CH1	Analog Input 2
13	CH2	Analog Input 3
14	CH3	Analog Input 4
15	NC_GND	Ground this pin to prevent ESD or Static Buildup
16	VCC	DC Supply Voltage.

## PIN-OUT DESCRIPTION

## ABSOLUTE MAXIMUM RATINGS

Parameter	Range	Units
Case Operating Temperature Range	-55 to +125	°C
Storage Temperature Range	-65 to +150	°C
Supply Voltage (+VCC)	+6.0	V
Digital Input Overvoltage (VEN, VA)	< VCC +0.4 > GND -0.4	V V
Analog Input Over Voltage (CH0-CH7)	< VCC +0.4 > GND -0.4	V

NOTICE: Stresses above those listed under "Absolute Maximum Ratings" may cause permanent damage to the device. These are stress rating only; functional operation beyond the "Operation Conditions" is not recommended and extended exposure beyond the "Operation Conditions" may affect device reliability.

## RECOMMENDED OPERATING CONDITIONS

Symbol	Parameter	Typical	Units
+VCC	Power Supply Voltage	3.3 to 5.0	V
VEN, VA	Logic Low Level	30% VCC	V
VEN, VA	Logic High Level	70% VCC	V

## ELECTRICAL PERFORMANCE CHARACTERISTICS

(Tc = -55°C TO +125°C, +VCC = +5V -- UNLESS OTHERWISE SPECIFIED)

Parameter	Symbol	Conditions	Min	Max	Units	
Supply Current (+VCC)	+ICC	$\overline{EN} = 30\% VCC$	-	10	μA	
	+ISBY	$\overline{EN} = 70\% VCC$	-	10	μA	
Address Input Current (A0-A2)	IAL	VA = 30% VCC	+25°C	-5	5	nA
			+125°C	-50	50	nA
	IAH	VA = 70% VCC	+25°C	-5	5	nA
			+125°C	-50	50	nA
Enable Input Current ( $\overline{EN}$ )	IENL	VEN = 30% VCC	+25°C	-5	5	nA
			+125°C	-50	50	nA
	IENH	VEN = 70%VCC	+25°C	-5	5	nA
			+125°C	-50	50	nA
High Input Leakage Current (CH0-CH7)	IINLK <sub>5</sub>	VIN = +5V, VEN = 70% VCC, Output and all unused MUX inputs under test = 0V	+25°C	-5	5	nA
			+125°C	-50	50	nA
Low Input Leakage Current (CH0-CH7)	IINLK <sub>0</sub>	VIN = 0V, VEN = 70% VCC Output and all unused MUX inputs under test = +5V	+25°C	-5	5	nA
			+125°C	-50	50	nA
Output Leakage Current (VOUT)	IOUTLK	VOUT = +5V, VEN = 70% VCC , All inputs grounded except channel being tested	+25°C	-5	5	nA
			+125°C	-50	50	nA
Switch ON Resistance	RDSON	VIN = 0V, VIN = +2.5V, VIN = +5V VEN = 30% VCC IOUT = -1mA	-55°C	-	500	Ω
			+25°C	-	750	Ω
			+125°C	-	1000	Ω

## SWITCHING CHARACTERISTICS

(T<sub>C</sub> = -55°C TO +125°C, +V<sub>CC</sub> = +5V -- UNLESS OTHERWISE SPECIFIED)

Parameter	Symbol	Conditions	Temp	Min	Max	Units
Address to Output Delay	t <sub>AHL</sub>	V <sub>OUT</sub> High to Low Transition	-55°C	10	150	ns
			+25°C	10	150	ns
			+125°C	10	200	ns
	t <sub>ALH</sub>	V <sub>OUT</sub> Low to High Transition	-55°C	10	150	ns
			+25°C	10	150	ns
			+125°C	10	200	ns
Enable to Output Delay	t <sub>ONEN</sub>	(Enabled)	-55°C	10	150	ns
			+25°C	10	150	ns
			+125°C	10	200	ns
	t <sub>OFFEN</sub>	(Disabled)	ALL	10	200	ns

## TRUTH TABLE (CH0 – CH7)

A2	A1	A0	$\overline{\text{EN}}$	"ON" CHANNEL 1/
X	X	X	H	NONE
L	L	L	L	CH0
L	L	H	L	CH1
L	H	L	L	CH2
L	H	H	L	CH3
H	L	L	L	CH4
H	L	H	L	CH5
H	H	L	L	CH6
H	H	H	L	CH7

1/ Between (CH0-CH7) and V<sub>OUT</sub>

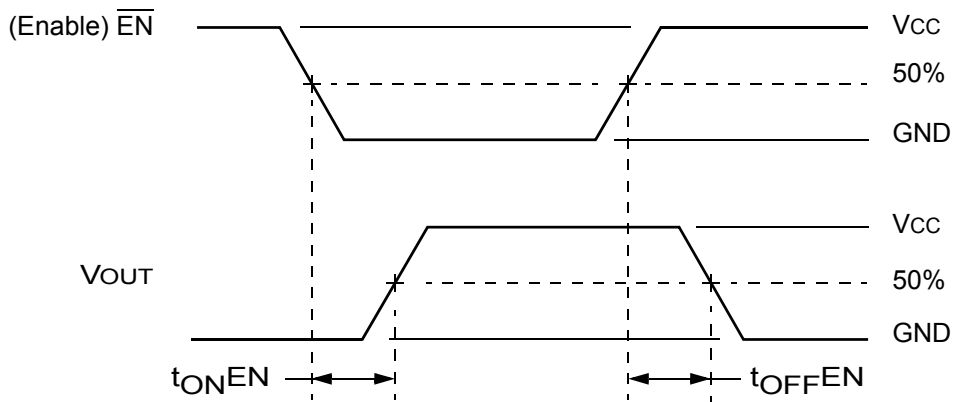
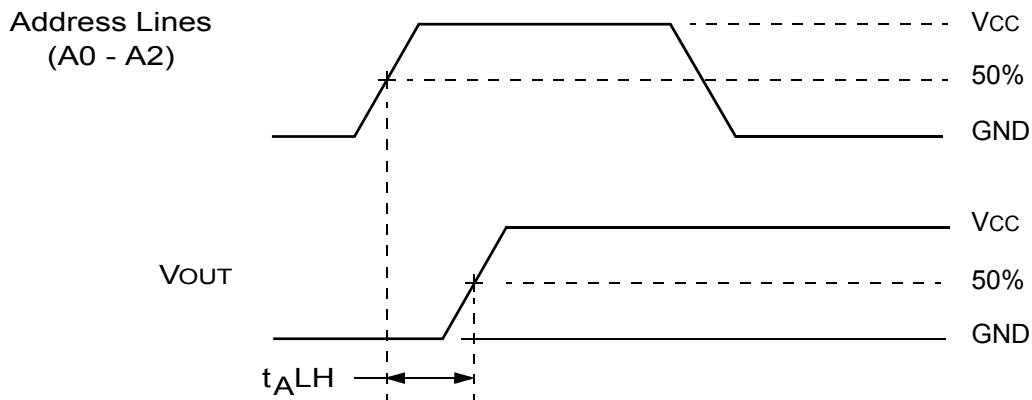
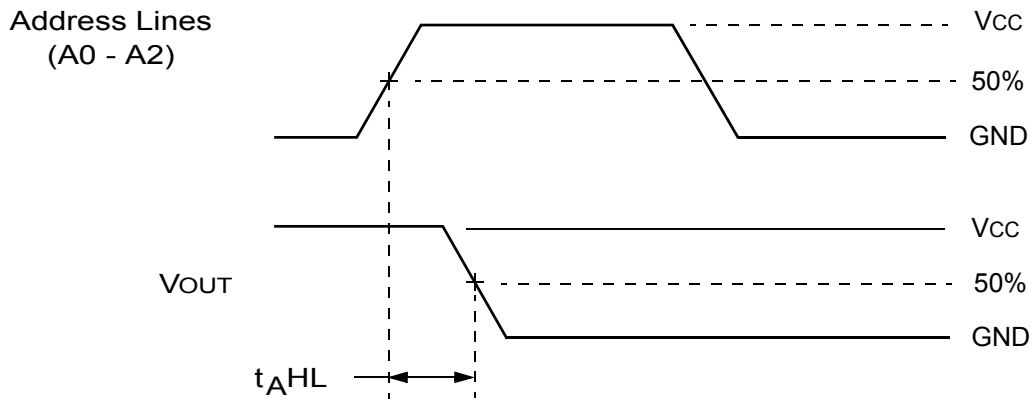

NOTE:  $f = 10\text{KHz}$ , Duty cycle = 50%.

## RHD5928 SWITCHING DIAGRAMS

## ORDERING INFORMATION

Model	DLA SMD #	Screening	Package
RHD5928-7	-	Commercial Flow, +25°C testing only	16-pin SOIC
RHD5928-S	-	Military Temperature, -55°C to +125°C Screened in accordance with the individual Test Methods of MIL-STD-883 for Space Applications	
RHD5928-201-1S	5962-1220801KXC	DLA SMD Pending	
RHD5928-201-2S	5962-1220801KXA		
RHD5928-901-1S	5962H1220801KXC	DLA SMD and Radiation Certification Pending	
RHD5928-901-2S	5962H1220801KXA		

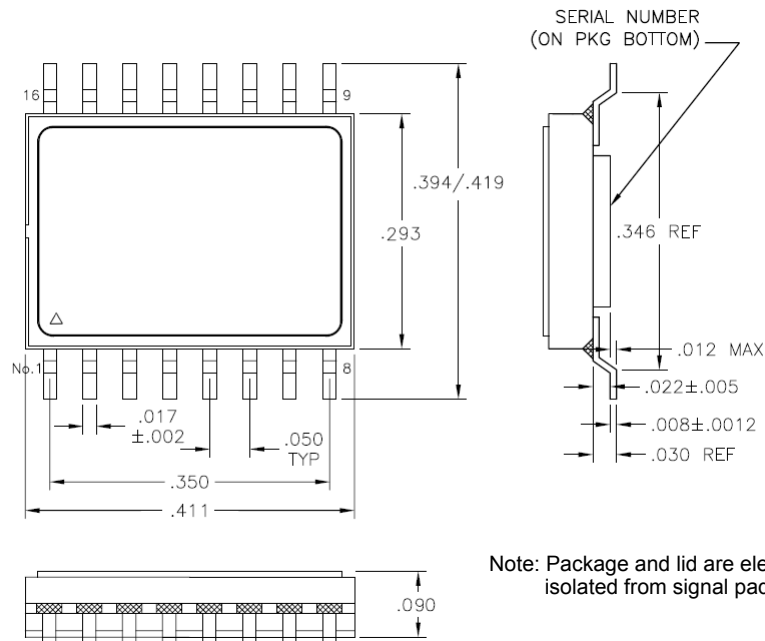

### PACKAGE OUTLINE

#### EXPORT CONTROL:

*This product is controlled for export under the International Traffic in Arms Regulations (ITAR). A license from the U.S. Department of State is required prior to the export of this product from the United States.*

#### EXPORT WARNING:

*Aeroflex's military and space products are controlled for export under the International Traffic in Arms Regulations (ITAR) and may not be sold or proposed or offered for sale to certain countries. (See ITAR 126.1 for complete information.)*

**PLAINVIEW, NEW YORK**  
Toll Free: 800-THE-1553  
Fax: 516-694-6715

**INTERNATIONAL**  
Tel: 805-778-9229  
Fax: 805-778-1980

**NORTHEAST**  
Tel: 603-888-3975  
Fax: 603-888-4585

**SE AND MID-ATLANTIC**  
Tel: 321-951-4164  
Fax: 321-951-4254

**WEST COAST**  
Tel: 949-362-2260  
Fax: 949-362-2266

**CENTRAL**  
Tel: 719-594-8017  
Fax: 719-594-8468

[www.aeroflex.com](http://www.aeroflex.com)    [info-ams@aeroflex.com](mailto:info-ams@aeroflex.com)

Aeroflex Microelectronic Solutions reserves the right to change at any time without notice the specifications, design, function, or form of its products described herein. All parameters must be validated for each customer's application by engineering. No liability is assumed as a result of use of this product. No patent licenses are implied.



Our passion for performance is defined by three attributes represented by these three icons: solution-minded, performance-driven and customer-focused