

# RadHard-by-Design RHD5922 Analog Multiplexer 16-Channel, Sample-and-Hold

[www.aeroflex.com/RHDseries](http://www.aeroflex.com/RHDseries)

March 8, 2011



**AEROFLEX**  
A passion for performance.

## FEATURES

- Single power supply operation at 3.3V to 5V
- Radiation performance
  - Total dose: >1Mrad(Si); Dose rate = 50 - 300 rads(Si)/s
  - ELDRS Immune
  - SEL Immune >100 MeV-cm<sup>2</sup>/mg
  - Neutron Displacement Damage >10<sup>14</sup> neutrons/cm<sup>2</sup>
- Full military temperature range
- CMOS analog switching allows rail to rail operation
- Address bus (A0-3), and one sample-and-hold line
- Designed for aerospace and high reliability space applications
- Packaging – Hermetic ceramic
  - 24-pin, 0.3"W x 0.6"L x 0.12"Ht SOIC
  - Typical Weight 2 grams
- DSCC SMD 5962-10243 pending

## GENERAL DESCRIPTION

Aeroflex's RHD5922 is a radiation hardened, single supply, 16 channel sample-and-hold multiplexer in a 24-pin SOIC package. The RHD5922 design uses specific circuit topology and layout methods to mitigate total ionizing dose effects and single event latchup. These characteristics make the RHD5922 especially suited for the harsh environment encountered in Deep Space missions. It is guaranteed operational from -55°C to +125°C. Available screened in accordance with MIL-PRF-38534 Class K, the RHD5922 is ideal for demanding military and space applications.

## ORGANIZATION AND APPLICATION

The RHD5922 is a 16 to 1 CMOS sample-and-hold multiplexer. Channel selection is controlled by a 4 bit address bus. Signal acquisition is controlled by the sample-and-hold. Low internal leakage allows for droop rate as low as 0.1V/sec All inputs and outputs are diode protected.

The devices will not latch with SEU events to above 100 MeV-cm<sup>2</sup>/mg. Total dose degradation is minimal to above 1Mrad(Si). Displacement damage environments to neutron fluence equivalents in the mid 10<sup>14</sup> neutrons per cm<sup>2</sup> range are readily tolerated. There is no sensitivity to low-dose rate (ELDRS) effects. SEU effects are application dependant.

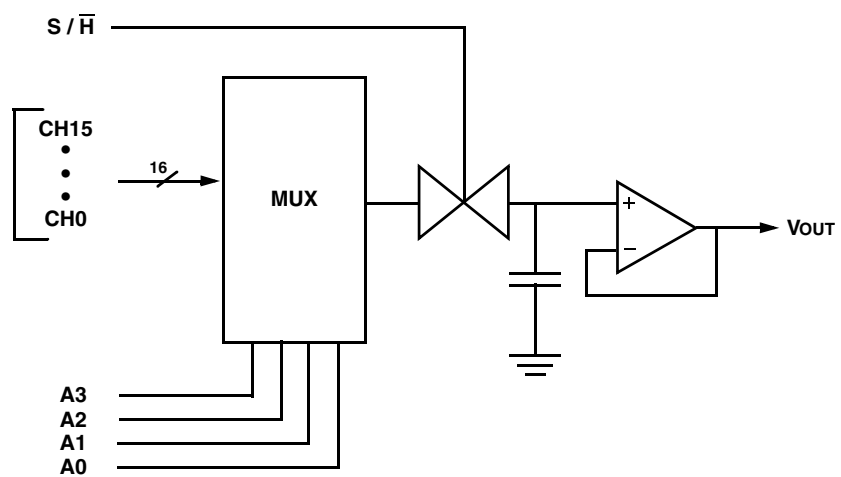
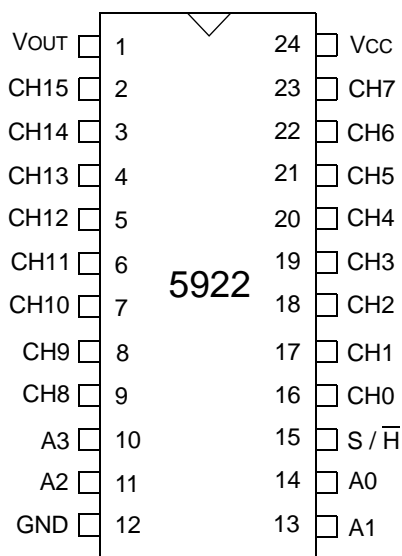

Notes:

1. Package and lid are electrically isolated from signal pads.

**RHD5922: 16 CHANNEL SAMPLE-AND-HOLD ANALOG MUX**

## ABSOLUTE MAXIMUM RATINGS

Parameter	Range	Units
Case Operating Temperature Range	-55 to +125	°C
Storage Temperature Range	-65 to +150	°C
Supply Voltage (+VCC)	+6.0	V
Digital Input Overvoltage (V <sub>S<math>\bar{H}</math></sub> , V <sub>A</sub> )	< V <sub>CC</sub> +0.4 > GND -0.4	V V
Analog Input Over Voltage (CH0-CH15)	< V <sub>CC</sub> +0.4 > GND -0.4	V

NOTICE: Stresses above those listed under "Absolute Maximums Rating" may cause permanent damage to the device. These are stress rating only; functional operation beyond the "Operation Conditions" is not recommended and extended exposure beyond the "Operation Conditions" may affect device reliability.

## RECOMMENDED OPERATING CONDITIONS

Symbol	Parameter	Typical	Units
+VCC	Power Supply Voltage	3.3 to 5.0	V
V <sub>S<math>\bar{H}</math></sub> , V <sub>A</sub>	Logic Low Level	30% V <sub>CC</sub>	V
V <sub>S<math>\bar{H}</math></sub> , V <sub>A</sub>	Logic High Level	70% V <sub>CC</sub>	V

## ELECTRICAL PERFORMANCE CHARACTERISTICS

(T<sub>C</sub> = -55°C TO +125°C, +V<sub>CC</sub> = +5V -- UNLESS OTHERWISE SPECIFIED)

Parameter	Symbol	Conditions	Min	Max	Units	
Supply Current (+VCC)	+I <sub>CC</sub>		10	100	uA	
Address Input Current (A0-A3)	I <sub>AL</sub> (0-3)	V <sub>A</sub> = 30% V <sub>CC</sub>	+25°C	-5	5	nA
			+125°C	-50	50	nA
	I <sub>AH</sub> (0-3)	V <sub>A</sub> = 70% V <sub>CC</sub>	+25°C	-5	5	nA
			+125°C	-50	50	nA
Sample-and-Hold Input Current (S / $\bar{H}$ )	I <sub>S<math>\bar{H}</math></sub>	V <sub>S<math>\bar{H}</math></sub> = 30% V <sub>CC</sub>	+25°C	-5	5	nA
			+125°C	-50	50	nA
	I <sub>S<math>\bar{H}</math></sub>	V <sub>S<math>\bar{H}</math></sub> = 70% V <sub>CC</sub>	+25°C	-5	5	nA
			+125°C	-50	50	nA
Input Leakage Current (CH0-CH15)	+I <sub>INLK</sub>	V <sub>IN</sub> = +5V, V <sub>S<math>\bar{H}</math></sub> = 70% V <sub>CC</sub>	+25°C	-5	5	nA
			+125°C	-50	50	nA
Output ON Voltage	V <sub>ON1</sub>	V <sub>IN</sub> = +5V, R <sub>L</sub> = 10K	4.9	5.1	V	
	V <sub>ON2</sub>	V <sub>IN</sub> = +5V, R <sub>L</sub> = 1K	4.35	4.65	V	
	V <sub>ON3</sub>	V <sub>IN</sub> = +3.3V, R <sub>L</sub> = 10K	3.2	3.4	V	
Input Load Capacitance	C <sub>IN</sub>			35	pF	

## SWITCHING CHARACTERISTICS

(T<sub>C</sub> = -55°C TO +125°C, +V<sub>CC</sub> = +5V -- UNLESS OTHERWISE SPECIFIED)

Parameter	Symbol	Conditions	Min	Max	Units
Address (low-to-high) to Output	t <sub>AHL</sub>	f = 10KHz, V <sub>IN</sub> = +5V, R <sub>L</sub> = 10kΩ	1	5	us
Address (high-to-low) to Output	t <sub>ALH</sub>	f = 10KHz, V <sub>IN</sub> = +5V, R <sub>L</sub> = 10kΩ	1	5	us
Droop Rate	DR		-	0.1	V/s
Data Setup Time	t <sub>DS</sub>		150	-	ns
Data Hold Time	t <sub>DH</sub>		150	-	ns

## TRUTH TABLE (CH0 – CH15)

A3	A2	A1	A0	"ON" CHANNEL <u>1</u> / <sub>1</sub>
L	L	L	L	CH0
L	L	L	H	CH1
L	L	H	L	CH2
L	L	H	H	CH3
L	H	L	L	CH4
L	H	L	H	CH5
L	H	H	L	CH6
L	H	H	H	CH7
H	L	L	L	CH8
H	L	L	H	CH9
H	L	H	L	CH10
H	L	H	H	CH11
H	H	L	L	CH12
H	H	L	H	CH13
H	H	H	L	CH14
H	H	H	H	CH15

1/<sub>1</sub> Between (CH0-CH15) and V<sub>OUT</sub>

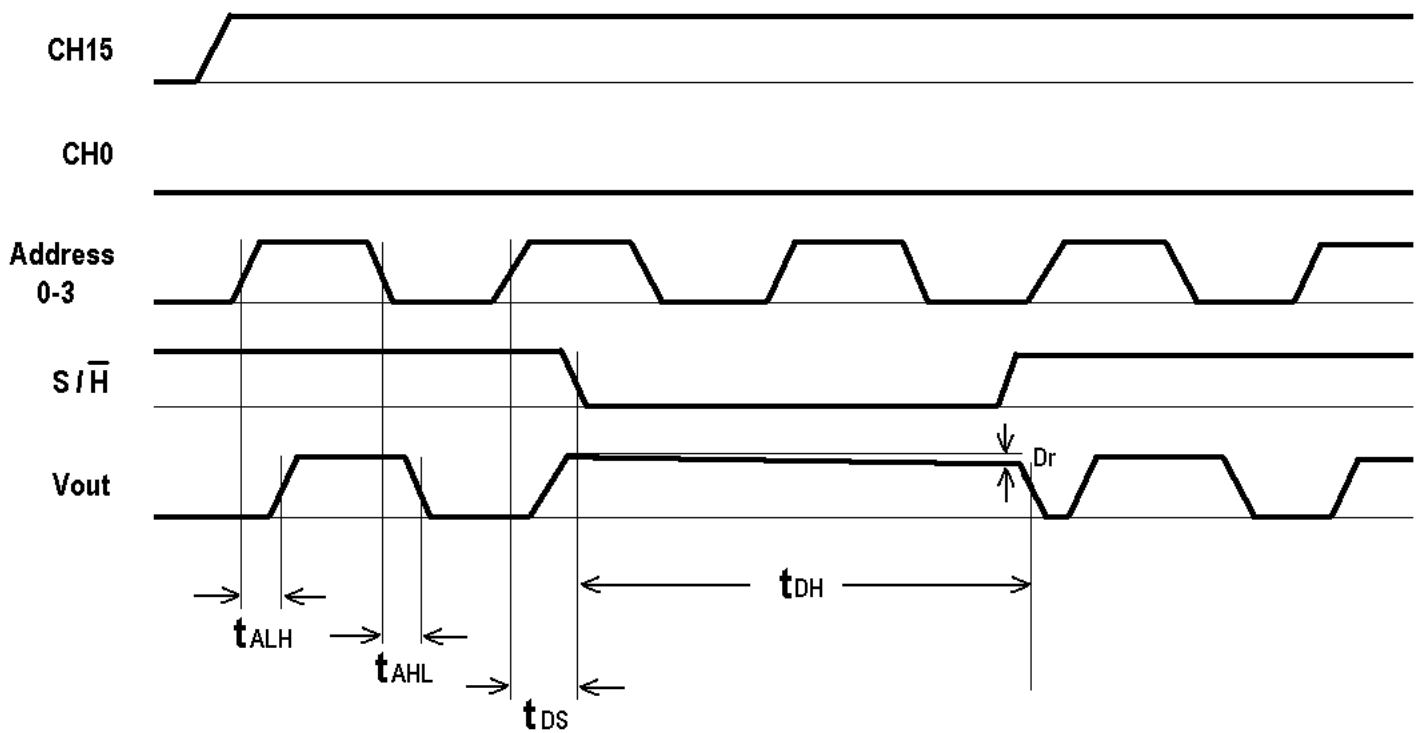

## RHD5922 SWITCHING DIAGRAMS

## ORDERING INFORMATION

Model	DSCC SMD #	Screening	Package
RHD5922-7	-	Commercial Flow, +25°C testing only	24-pin SOIC
RHD5922-S	-	Military Temperature, -55°C to +125°C Screened in accordance with MIL-PRF-38534, Class K	
RHD5922-201-1S	5962-1024303KXC (Pending)	In accordance with DSCC SMD (Pending)	
RHD5922-201-2S	5962-1024303KXA (Pending)		
RHD5922-901-1S	5962H1024303KXC (Pending)		
RHD5922-901-2S	5962H1024303KXA (Pending)		

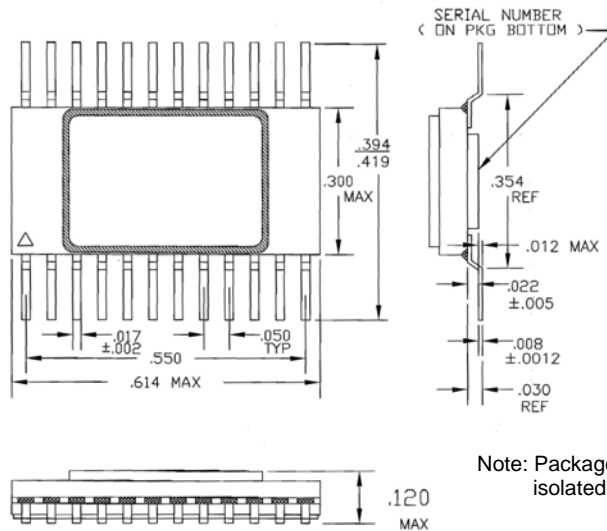

Note: Package and lid are electrically isolated from signal pads.

### PACKAGE OUTLINE

#### EXPORT CONTROL:

This product is controlled for export under the International Traffic in Arms Regulations (ITAR). A license from the U.S. Department of State is required prior to the export of this product from the United States.

#### EXPORT WARNING:

Aeroflex's military and space products are controlled for export under the International Traffic in Arms Regulations (ITAR) and may not be sold or proposed or offered for sale to certain countries. (See ITAR 126.1 for complete information.)

**PLAINVIEW, NEW YORK**  
Toll Free: 800-THE-1553  
Fax: 516-694-6715

**INTERNATIONAL**  
Tel: 805-778-9229  
Fax: 805-778-1980

**NORTHEAST**  
Tel: 603-888-3975  
Fax: 603-888-4585

**SE AND MID-ATLANTIC**  
Tel: 321-951-4164  
Fax: 321-951-4254

**WEST COAST**  
Tel: 949-362-2260  
Fax: 949-362-2266

**CENTRAL**  
Tel: 719-594-8017  
Fax: 719-594-8468

[www.aeroflex.com](http://www.aeroflex.com)    [info-ams@eroflex.com](mailto:info-ams@eroflex.com)



Aeroflex Microelectronic Solutions reserves the right to change at any time without notice the specifications, design, function, or form of its products described herein. All parameters must be validated for each customer's application by engineering. No liability is assumed as a result of use of this product. No patent licenses are implied.



Our passion for performance is defined by three attributes represented by these three icons: solution-minded, performance-driven and customer-focused