

Standard Products

MUX8562 Dual 16-Channel Analog Multiplexer Module +5V, Radiation Tolerant

www.aeroflex.com/mux

Preliminary

December 7, 2009

AEROFLEX
A passion for performance.



FEATURES

- 32-channels provided by two independent 16-channel multiplexers
- Single +5V power supply
- Radiation performance
 - Total dose: 150 krad(Si), Dose rate = 50 - 300 rad(Si)/s
 - SEU: Immune up to 90 MeV-cm²/mg
 - SEL: Immune by process design
- Full military temperature range
- Low power consumption < 5mW
- CMOS analog switching allows rail to rail operation and low switch impedance
- Separate address (A0-3 & B0-3) and enable ($\overline{EN}0-15$ & $\overline{EN}16-31$) for CH0-15 and CH16-31
- Fast access time < 500ns typical
- Break-Before-Make switching
- High analog input impedance (power on or off)
- Designed for aerospace and high reliability space applications
- Packaging – Hermetic ceramic
 - 56 leads, 0.80" Sq x 0.20"Ht quad flat pack
 - Typical Weight 6 grams
- DSCC SMD 5962-10209 pending

Note: Aeroflex Plainview does not currently have a DSCC certified Radiation Hardened Assurance Program.

GENERAL DESCRIPTION

Aeroflex's MUX8562 is a radiation tolerant +5V only Dual 16 channel multiplexer MCM (Multi Chip Module).

The MUX8562 has been specifically designed to meet exposure to radiation environments. It is available in a 56 lead High Temperature Co-Fired Ceramic (HTCC) Quad Flatpack (CQFP). It is guaranteed operational from -55°C to +125°C. Available screened in accordance with MIL-PRF-38534, the MUX8562 is ideal for demanding military and space applications.

ORGANIZATION AND APPLICATION

The MUX8562 consists of two independent 16 channel +5V only multiplexers arranged as shown in the block diagram.

A Section

Sixteen (16) channels addressable by bus A₀~A₃, enabled by $\overline{EN}0-15$ and outputted on Output1 (0-15).

B Section

Sixteen (16) channels addressable by bus B₀~B₃, enabled by $\overline{EN}16-31$ and outputted on Output2 (16-31).

SECTION A

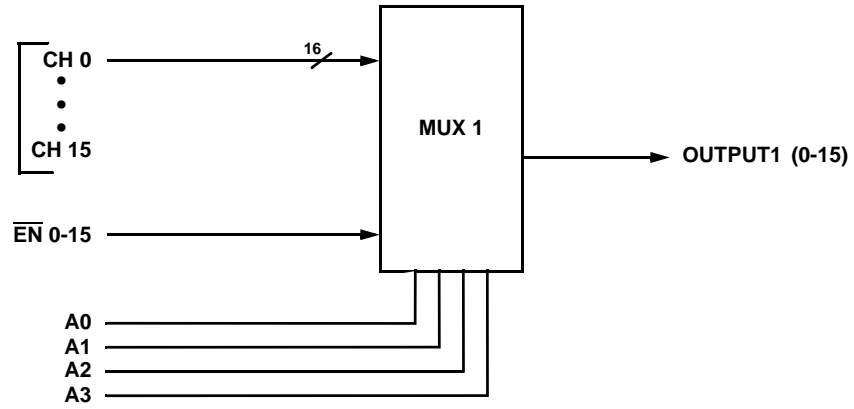

SECTION B

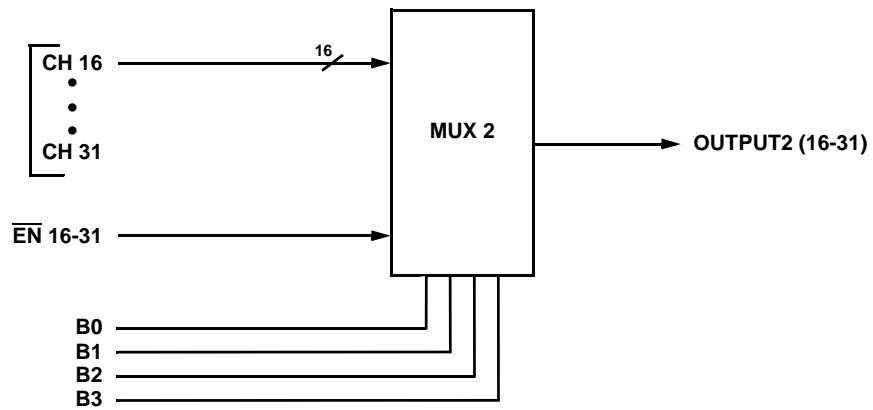

MUX8562: DUAL 16 CHANNEL ANALOG MUX BLOCK DIAGRAM

ABSOLUTE MAXIMUM RATINGS 1/

Parameter	Range	Units
Case Operating Temperature Range	-55 to +125	°C
Storage Temperature Range	-65 to +150	°C
Supply Voltage +VEE (Pin 18) VREF (Pin 39)	+7.5 +7.5	V V
Digital Input Overvoltage VEN0-15 (Pin 13), VEN16-31 (Pin 44), VA (Pins 14, 15, 16, 17), VB (Pins 40, 41, 42, 43)	< VREF +0.5 > GND -0.5	V V
Analog Input Over Voltage Vs	$-0.5 \leq V_s \leq +7.5$	V

Notes:

1/ All measurements are made with respect to ground.

NOTICE: Stresses above those listed under "Absolute Maximums Rating" may cause permanent damage to the device. These are stress rating only; functional operation beyond the "Operation Conditions" is not recommended and extended exposure beyond the "Operation Conditions" may affect device reliability.

RECOMMENDED OPERATING CONDITIONS 1/

Symbol	Parameter	Typical	Units
+VEE	+5V Power Supply Voltage	+5.0	V
VREF	Reference Voltage	+5.00	V
VAL	Logic Low Level	+0.8	V
VAH	Logic High Level	+4.0	V

1/ Power Supply turn-on sequence shall be as follows: +VEE, followed by VREF (or tie these together).

DC ELECTRICAL PERFORMANCE CHARACTERISTICS 1/

(TC = -55°C to +125°C, +V EE = +5V, VREF = +5.0V - Unless otherwise specified)

Parameter	Symbol	Conditions	Min	Max	Units
Supply Current	+IEE	VEN(0-15) = VEN(16-31) = VA(0-3) = VB(0-3) = 0	0	1	mA
	+ISBY	VEN(0-15) = VEN(16-31) = 4V, VA(0-3) = VB(0-3) = 0 1/	0	1	mA
Address Input Current	I _{AL} (0-3)A	VA = 0V	-0.5	0.5	μA
	I _{AH} (0-3)A	VA = 5V	-0.5	0.5	μA
	I _{AL} (0-3)B	VB = 0V	-0.5	0.5	μA
	I _{AH} (0-3)B	VB = 5V	-0.5	0.5	μA
Enable Input Current	I _{ENL} (0-15)	VEN(0-15) = 0V	-0.5	0.5	μA
	I _{ENH} (0-15)	VEN(0-15) = 5V	-0.5	0.5	μA
	I _{ENL} (16-31)	VEN(16-31) = 0V	-0.5	0.5	μA
	I _{ENH} (16-31)	VEN(16-31) = 5V	-0.5	0.5	μA

DC ELECTRICAL PERFORMANCE CHARACTERISTICS 1/ (continued)

(TC = -55°C to +125°C, +V_{EE} = +5V, V_{REF} = +5.0V - Unless otherwise specified)

Parameter	Symbol	Conditions	Min	Max	Units
Positive Input Leakage Current CH0-CH31	+ISOFFOUTPUT(ALL)	V _{IN} = +5V, V _{EN} = 4V, output and all unused MUX inputs under test = 0V <u>2/</u> , <u>3/</u>	-100	+100	nA
Negative Input Leakage Current CH0-CH31	-ISOFFOUTPUT(ALL)	V _{IN} = 0V, V _{EN} = 4V, output and all unused MUX inputs under test = +5V <u>2/</u> , <u>3/</u>	-100	+100	nA
Positive Output Leakage Current OUTPUTS (pins 12,45)	+IDOFFOUTPUT(ALL)	V _{OUT} = +5V, V _{EN} = 4V, and inputs grounded except channel being tested. <u>3/</u> , <u>4/</u>	-50	+1500	nA
Switch ON Resistance OUTPUTS (pins 12,45) <u>6/</u>	R _{DS(ON)} (0-31) _A	V _{IN} = +5V, V _{EN} = 0.8V, I _{OUT} = -1mA <u>2/</u> , <u>3/</u> , <u>5/</u>	50	1000	Ω

Notes:

- 1/ Measure inputs sequentially. Ground all unused inputs of the device under test. V_A is the applied input voltage to the address lines A(0-3). V_B is the applied input voltage to the address lines B(0-3).
- 2/ V_{IN} is the applied input voltage to the input channels CH0-CH31.
- 3/ V_{EN} is the applied input voltage to the enable line EN(0-15) and EN(16-31)
- 4/ V_{OUT} is the applied input voltage to the output lines OUTPUT1 (0-15), OUTPUT2 (16-31)
- 5/ Negative current is the current flowing out of each of the MUX pins. Positive current is the current flowing into each MUX pin.
- 6/ The MUX8562 cannot be operated with analog inputs below 0 volts.
- 7/ Not tested, guaranteed to the specified limits.

SWITCHING CHARACTERISTICS

((TC = -55°C TO +125°C, +V_{EE} = +5V, V_{REF} = +5.0V - UNLESS OTHERWISE SPECIFIED))

Parameter	Symbol	Conditions	Min	Max	Units
Switching Test MUX	t _{AHL}	R _L = 10KΩ, C _L = 50pF	100	700	ns
	t _{ALH}		100	700	ns
	t _{ONEN}	R _L = 1KΩ, C _L = 50pF	100	700	ns
	t _{OFFEN}		100	700	ns

TRUTH TABLE (CH0 – CH15)

A3	A2	A1	A0	\overline{EN} (0-15)	"ON" CHANNEL, $\frac{1}{2}$ (OUTPUT 1)
X	X	X	X	H	NONE
L	L	L	L	L	CH0
L	L	L	H	L	CH1
L	L	H	L	L	CH2
L	L	H	H	L	CH3
L	H	L	L	L	CH4
L	H	L	H	L	CH5
L	H	H	L	L	CH6
L	H	H	H	L	CH7
H	L	L	L	L	CH8
H	L	L	H	L	CH9
H	L	H	L	L	CH10
H	L	H	H	L	CH11
H	H	L	L	L	CH12
H	H	L	H	L	CH13
H	H	H	L	L	CH14
H	H	H	H	L	CH15

$\frac{1}{2}$ Between CH0-15 and OUTPUT1 (0-15)

TRUTH TABLE (CH16 – CH31)

B3	B2	B1	B0	\overline{EN} (16-31)	"ON" CHANNEL, $\frac{1}{2}$ (OUTPUT 2)
X	X	X	X	H	NONE
L	L	L	L	L	CH16
L	L	L	H	L	CH17
L	L	H	L	L	CH18
L	L	H	H	L	CH19
L	H	L	L	L	CH20
L	H	L	H	L	CH21
L	H	H	L	L	CH22
L	H	H	H	L	CH23
H	L	L	L	L	CH24
H	L	L	H	L	CH25
H	L	H	L	L	CH26
H	L	H	H	L	CH27
H	H	L	L	L	CH28
H	H	L	H	L	CH29
H	H	H	L	L	CH30
H	H	H	H	L	CH31

$\frac{1}{2}$ Between CH16-31 and OUTPUT2 (16-31)

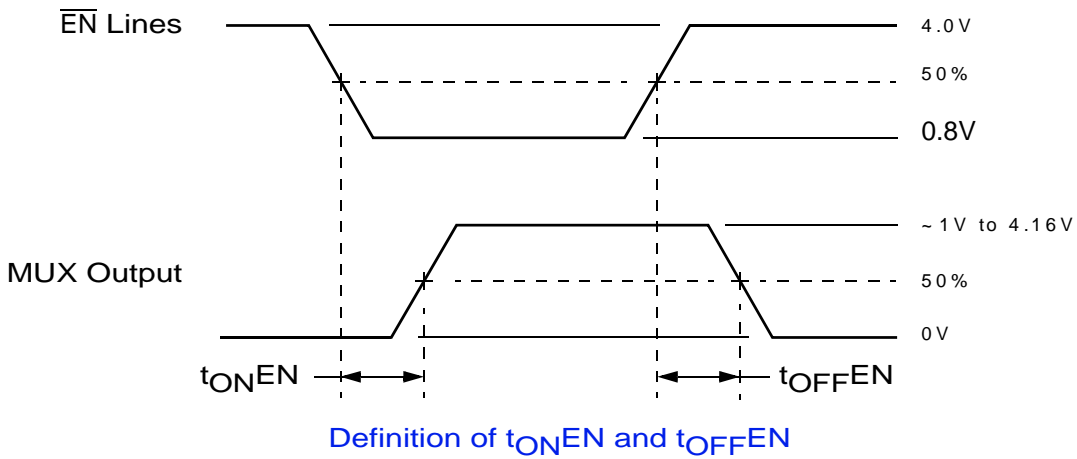
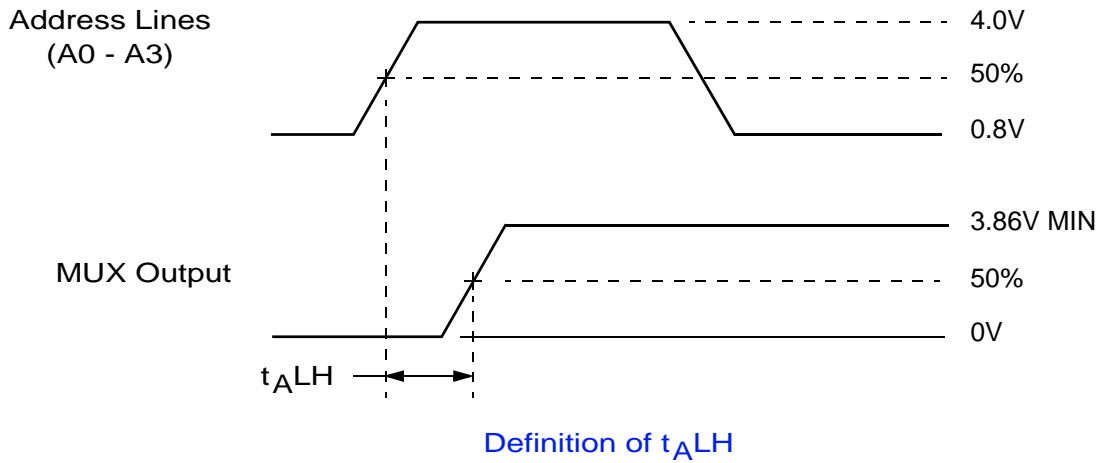
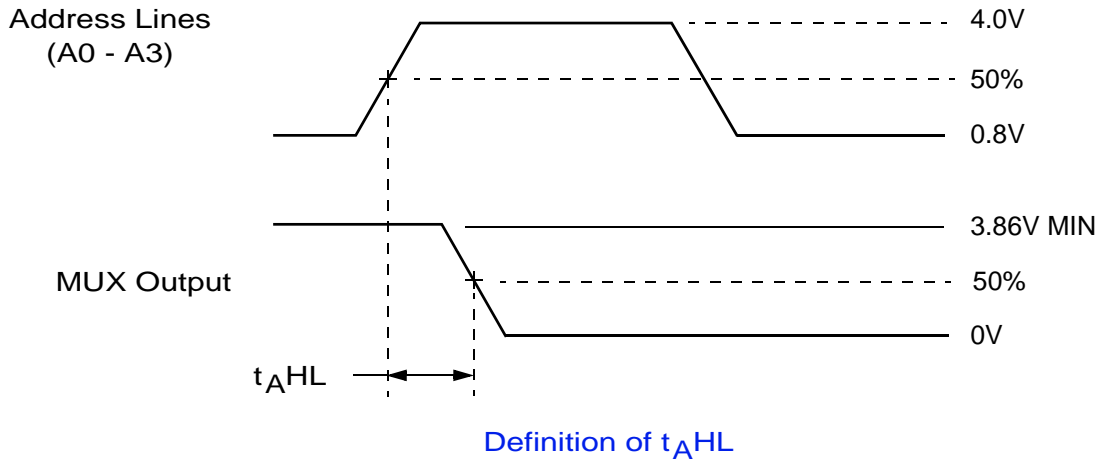

NOTE: $f = 10\text{KHz}$, Duty cycle = 50%.

MUX8562 SWITCHING DIAGRAMS

PIN NUMBERS & FUNCTIONS

MUX8562 – 56 Leads Ceramic QUAD Flat Pack			
Pin #	Function	Pin #	Function
1	CH0	29	CH31
2	CH1	30	CH30
3	CH2	31	CH29
4	CH3	32	CH28
5	CH4	33	CH27
6	CH5	34	CH26
7	GND	35	GND
8	GND	36	GND
9	CH6	37	CH25
10	CH7	38	CH24
11	CASE GND	39	VREF
12	OUTPUT1 (0-15)	40	B3
13	$\overline{\text{EN}}$ 0-15	41	B2
14	A0	42	B1
15	A1	43	B0
16	A2	44	$\overline{\text{EN}}$ 16-31
17	A3	45	OUTPUT2 (16-31)
18	+VEE	46	GND
19	CH15	47	CH16
20	CH14	48	CH17
21	GND	49	GND
22	GND	50	GND
23	CH13	51	CH18
24	CH12	52	CH19
25	CH11	53	CH20
26	CH10	54	CH21
27	CH9	55	CH22
28	CH8	56	CH23

Notes:

- Package lid is internally connected to circuit ground (Pins 7, 8, 11, 21, 22, 35, 36, 46, 49, 50).

ORDERING INFORMATION

Model	DSCC SMD #	Screening	Package
MUX8562-S	-	Military Temperature, -55°C to +125°C Screened in accordance with MIL-PRF-38534, Class K	QUAD Flat Pack
MUX8562-7	-	Commercial Flow, +25°C testing only	
MUX8562-201-1S	5962-1020901KXC Pending	In accordance with DSCC SMD	

PACKAGE OUTLINE

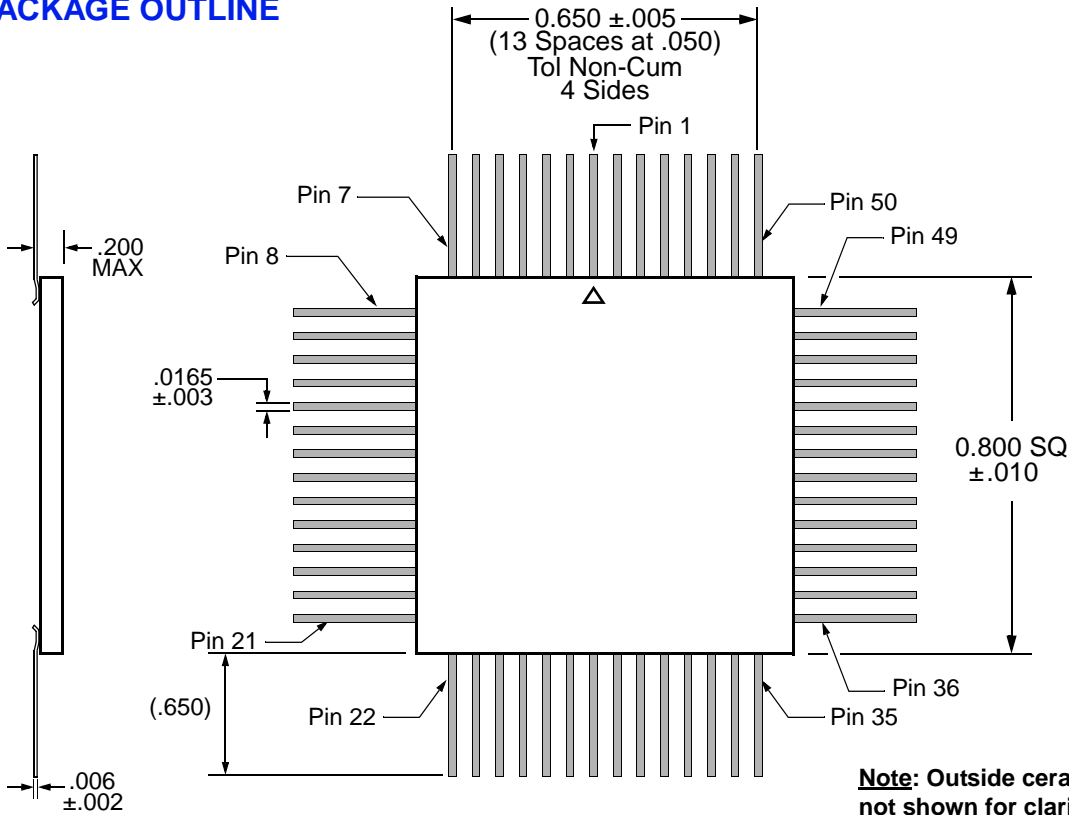

Note: Outside ceramic tie bars not shown for clarity. Contact factory for details.

EXPORT CONTROL:

This product is controlled for export under the International Traffic in Arms Regulations (ITAR). A license from the U.S. Department of State is required prior to the export of this product from the United States.

EXPORT WARNING:

Aeroflex's military and space products are controlled for export under the International Traffic in Arms Regulations (ITAR) and may not be sold or proposed or offered for sale to certain countries. (See ITAR 126.1 for complete information.)

PLAINVIEW, NEW YORK
Toll Free: 800-THE-1553
Fax: 516-694-6715

INTERNATIONAL
Tel: 805-778-9229
Fax: 805-778-1980

NORTHEAST
Tel: 603-888-3975
Fax: 603-888-4585

SE AND MID-ATLANTIC
Tel: 321-951-4164
Fax: 321-951-4254

WEST COAST
Tel: 949-362-2260
Fax: 949-362-2266

CENTRAL
Tel: 719-594-8017
Fax: 719-594-8468

www.aeroflex.com info-ams@eroflex.com



Aeroflex Microelectronic Solutions reserves the right to change at any time without notice the specifications, design, function, or form of its products described herein. All parameters must be validated for each customer's application by engineering. No liability is assumed as a result of use of this product. No patent licenses are implied.



Our passion for performance is defined by three attributes represented by these three icons: solution-minded, performance-driven and customer-focused