

## Model 8210A SmartStep® Programmable Attenuator/ Switch Controller



RS232/RS422/RS485



*A Logical Interface for Switchable Devices!*



### Features

- /// Provides a flexible, powerful, low cost solution for bus control of programmable step attenuators and other switchable devices under computer control.
- /// Designed to interface with Aeroflex / Weinschel's line of intelligent programmable attenuators and other electromechanical devices.
- /// Simplifies your bench test setups and subsystem design.
- /// Available in two standard communication interfaces:
  - Model 8210A-1: GPIB/IEEE-488 (HS-488 ready)
  - Model 8210A-2: RS-232, RS-422, RS-485

### Description

Model 8210A represents a new concept in device control applications and provides a high level interface from various industry standard communications interfaces to the serial Driver Interface Bus.

The Device Interface Bus (DIB) is a system for connecting a number of relatively low-speed I/O devices to a host, providing a simple, uniform and inexpensive way to control a variety of devices via a single port. The DIB is based on the two-wire serial bus and several software protocol layers that allow the Model 8210A to address up to 125 peripheral devices with serial data rates of up to 100 KHz. The DIB may also be used to supply DC power to the devices, resulting in a simple, low-cost interconnection system.

This Programmable attenuator/switch controller is available in two models, each providing a different type of communications interface to suit user configuration requirements. Each model contains similar capabilities, and provides switch-selectable parameters to the interfaces' operation.

### Applications

Applications for the 8210A range from providing control of a single Programmable Attenuator in a bench test/lab environment using a PC and a terminal emulator, to complex system applications where the 8210A is employed to control many devices to create custom/semi-custom subsystems to reduce overall design cost. Aeroflex / Weinschel can provide a variety of custom designed driver interfaces for various devices, such as RF switches, relays, PIN attenuators, displays and other devices, as well as complete subsystem design and integration services. Contact us with your specialized needs.

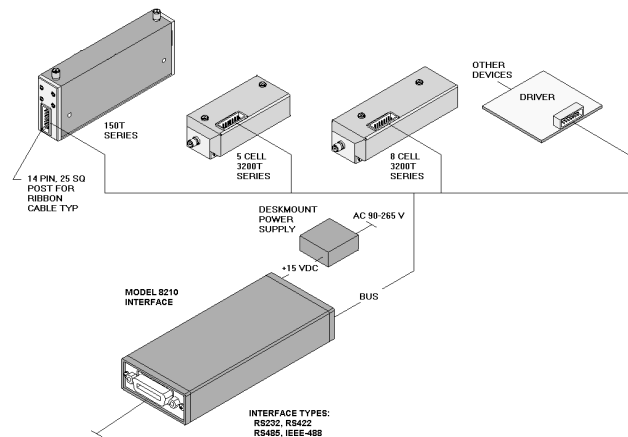

**Typical Capacity:** Control a subsystem consisting of 32 individual 8-cell programmable attenuators plus 16 DPDT switches.

### Accessories:

PART NUMBER	DESCRIPTION
001-378	Deskmount Power Supply, +15 V 95-250 Vac, 47-63 Hz ac input
193-8013	Interconnect Cable
193-8012	Attenuator Mounting Kit: This kit includes all hardware to allow the user to mount one attenuator onto the Model 8210A

For additional information on the Model 8210A, visit our website @ [www.aeroflex.com/AW/8210A](http://www.aeroflex.com/AW/8210A)

# Programmable Attenuators



## Specifications

SPECIFICATION	DESCRIPTION
<b>DC Input</b>	Connector: 2.5mm barrel style Requirements: +12 to +15 Vdc @ 250 mA
<b>Driver Interface</b>	Connector: 14-pin 0.025" square post header @ 0.1" centers. Mates with AMP 746285-2 or equivalent.  Signals : SDA serial data SDC serial clock VDC DC supply voltage GND ground  VDC Output Current: 2 A maximum Maximum Cable Length: 10 Meters (1000 pF maximum capacitance) Data Transfer Rate: 100 KHz
<b>Environmental</b>	Operating Temperature: 0 to +50°C Storage Temperature: -55° to +75°C (67° to +167°F) Humidity: 95% Altitude: 40,000' (12,192M)
<b>IEEE-488 Bus<sup>(1)</sup></b>	Connector: 24-pin per IEEE-488.1 Protocols: per IEEE-488.2 Indicators: Remote, Listen
<b>RS-232 Bus<sup>(2)</sup></b>	Connector: 9-pin male D Signals: TXD, RXD, RTS, CTS, DTR, GND Baud Rates: 2400, 9600, and 19200, 38400 Data Bits: 8 Handshaking: None, RTS/CTS, XON/XOFF Parity: None, Odd, Even Indicators: Tx (Transmit) and Rx (Receive Active)
<b>RS-422 Bus<sup>(3)</sup> &amp; RS-485 Bus<sup>(4)</sup></b>	Connector: 9-pin male D(Model 8210-2) Signals: TXD+, TDX-, RXD+, RTX-, RTS+, RTS-, CTS+, CTS-, & signal GND Baud Rates: 2400, 9600, and 19200, 38400 Data Bits: 8 Handshaking: None, RTS/CTS, XON/XOFF Parity: None, Odd, Even Indicators: Tx (Transmit) and Rx (Receive Active)

### Notes:

1. GPIB/IEEE-488 model allows user-selectable addresses.
2. RS-232 can be used with standard PC serial port for short and medium distances (up to approximately 50 ft).
3. RS-422, designed for very long distance communications (4000 ft) & optimized as a single node protocol, typically with one device connected to a single port.
4. RS-485, designed for very long distance communications (4000 ft) & optimized for multi-drop connections that can used to create a low cost network.

## Physical Dimensions

### Model 8210A-1 (IEEE-488):

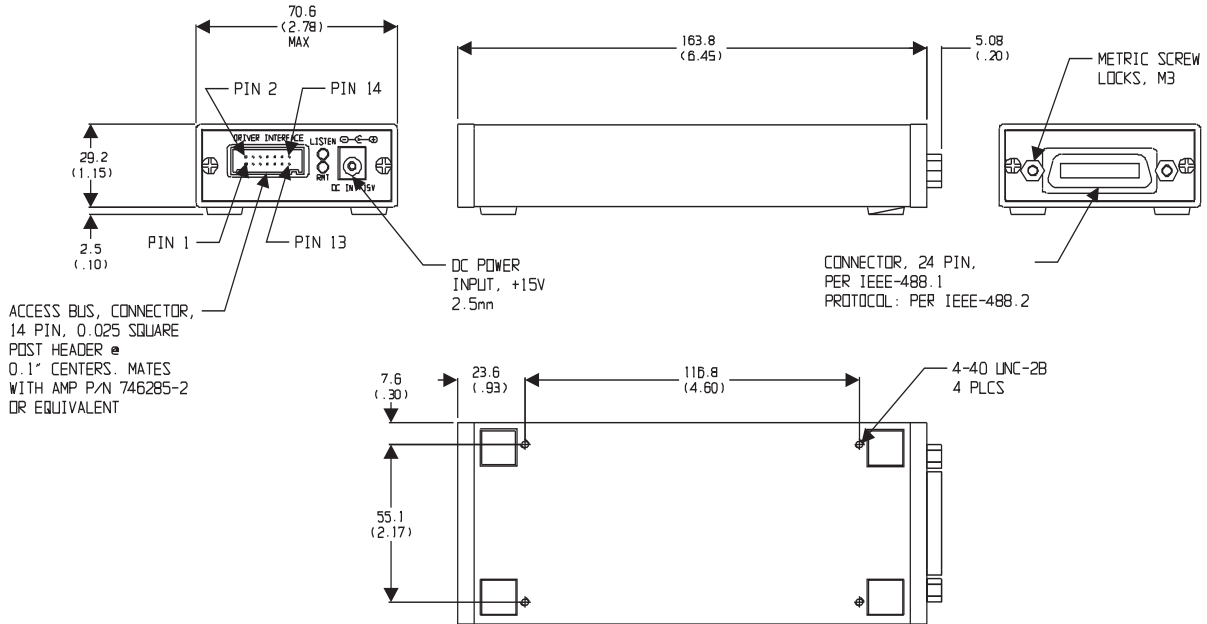

### Model 8210A-2 (RS-232/RS-422/RS-485):

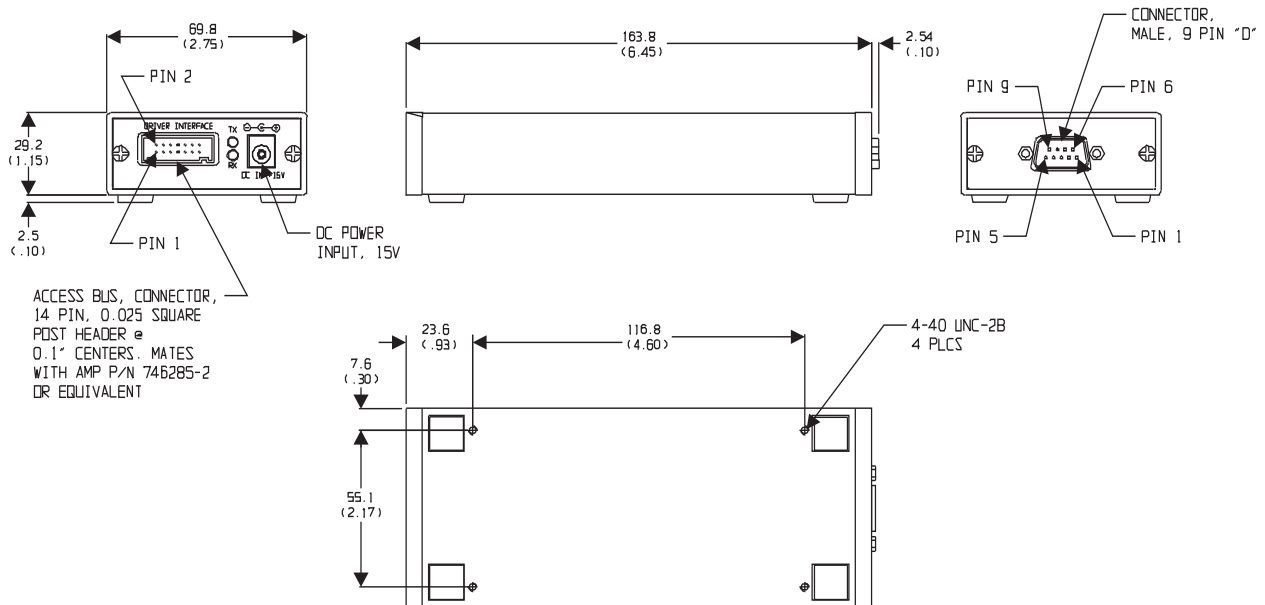

**NOTE:**

1. All dimensions are given in mm (inches) and are maximum, unless otherwise specified.
2. Unit weight: 318 g (11.2 oz)