

Models 8310 & 8311 Programmable Attenuator Units



RS232\RS422\RS485



Now Available with Ethernet Control!



Features

- /// Provides a flexible, easy to program, low cost solution for your bench test/calibration setups and subsystem applications.
- /// Multi-Channel attenuation paths (up to 4 input/outputs for 8310 & up to 6 input/outputs for 8311)
- /// Relative vs. Nominal attenuation step function.
- /// Wide choice of Frequency & Attenuation Ranges.
 - dc to 1, 2, 3, 6 & 18 GHz
 - NEW dc to 6 GHz Models
 - up to 127 dB
 - Solid-State (GaAs FET * & PIN)
 - Relay Switched
- /// Models with Ethernet Option - Specify when ordering.
- /// Accuracy & Repeatability.
- /// Designed to interface with Aeroflex / Weinschel's line of digitally controlled programmable attenuators and other electromechanical devices.
- /// Designed to interface with industry standard communication interfaces:
 - GPIB/IEEE-488 (HS-488 ready)
 - RS-232, RS-422, RS-485
 - New Models with Ethernet Control (10 BaseT)
- /// **Rack Configurable:** Model 8310 Series can be rack mounted either as a single unit using Rack Mounting Kit (P/N 193-8033-1) or two Model 8310's can be mounted together using Rack Mounting Kit (P/N 193-8033-2). These kits fit into any rack or cabinet that is designed per EIA RS-310 or MIL-STD-189. Rack ears are supplied with Model 8311 Series units.

Description

Aeroflex / Weinschel's 8310 and 8311 Series Programmable Attenuator Units represent a new concept in programmable attenuation for bench test and subsystem applications. Standard 8310 Series designs house and control various Aeroflex / Weinschel Programmable Attenuator Models (3200T, 150T, and 4200 Series) via front panel controls or standard communications interfaces including GPIB (IEEE-488), Ethernet and RS-232/RS-422/RS485. This series combines the features of the Aeroflex / Weinschel 8210A Device Controller with a front panel user interface to form a flexible, easy to use solution.

Most 8310 Series are single channel configurations where RF signal is routed through either the front or rear mounted Ports A & B but can be configured for up to four channels of attenuation, RF switching, amplification or other functions. Multiple programmable attenuators can be used in conjunction with other coaxial devices such as switches, power combiners, directional couplers, and filters creating single or multichannel subsystems.



Multi-Channel 19" Rack Size Versions

Applications

Applications for the 8310 and 8311 Series range from providing control of a single Programmable Attenuator in a bench test/lab environment using a PC and a terminal emulator, to complex system applications where the 8310/8311 Series are employed to control many devices to create custom/ semi-custom subsystems to reduce overall design cost. Aeroflex / Weinschel can provide a variety of custom designed driver interfaces for various devices, such as RF switches, relays, pin attenuators, motorized step attenuators, displays, and other devices, as well as complete subsystem design and integration services. Contact us with your specialized needs.

For additional information on the Model 8310, visit our website @ www.aeroflex.com/AW/8310.htm

Programmable Attenuators



Specifications

SPECIFICATION	DESCRIPTION
Input Power Requirements	ac 100 to 240 Vac, 50/60 Hz, 50 Watts
Environmental	Operating Temperature: 0 to +50°C Storage Temperature: 67° to +167 °F (-55° to +75°C) Humidity: 96% Altitude: 40,000' (12,192M)
IEEE-488 Bus (1)	Connector: 24-pin per IEEE-488.1 Protocols: per IEEE-488.2 Indicators: Remote (RMT), Listen (LSN), Talk (TLK), SRQ (SRQ)
RS-232 Bus (2) Serial I/O	Connector: 9-pin male D Signals: TXD, RXD, RTS, CTS, DTR, GND Baud Rates: 2400, 9600, 19200, and 38400 Data Bits: 8 Handshaking: None, RTS/CTS, XON/XOFF Parity: None, Odd, Even Indicators: Tx (Transmit) and Rx (Receive)
RS-422 BUS (3) RS-485 Bus (4)	Connector: 9-pin male D Signals: TXD+, TDX-, RXD+, RTX-, RTS+, RTS-, CTS+, CTS-, and signal GND Baud Rates: 2400, 9600, 19200, and 38400 Data Bits: 8 Handshaking: None, RTS/CTS, XON/XOFF Parity: None, Odd, Even Indicators: Tx (Transmit) and Rx (Receive)
Ethernet TC/IP	10 Base T Connector: Standard RJ45 Console Connector: 9-pin male D
RF Characteristics(5)	See ordering guides (pg 128 through 130)

1. GPIB/IEEE-488 model allows user-selectable addresses, Not included with Models with ethernet option.
2. RS-232 can be used with standard PC serial port for short and medium distances (up to approximately 50 ft).
3. RS-422, designed for very long distance communications (4000 ft) and optimized as a single node protocol, typically with one device connected to a single port.
4. RS-485, designed for very long distance communications (4000 ft) & optimized for multi-drop connections that can used to create a low cost network.
5. Refer to Individual data sheet for detailed specifications on internal programmables.

Ordering Guide...8310 Series with 4200 Programmables

Model No	Attenuation Value (dB)	Frequency Range (GHz)	Insertion Loss (maximum)	SWR (Maximum)	No of Channels	Attenuator Model No.*	Connector Type**	Conn Location
8310-136-F	63.75/0.25	0.8-2.5	6.0	1.6	1	4228-63.75	N/F	Front
8310-136-R	63.75/0.25	0.8-2.5	6.0	1.6	1	4228-63.75	N/F	Rear
8310-136-2-F	63.75/0.25	0.8-2.5	6.0	1.6	2	4228-63.75	N/F	Front
8310-136-2-R	63.75/0.25	0.8-2.5	6.0	1.6	2	4228-63.75	N/F	Rear
8310-137-F	63/1	0.8-3.0	4.7	1.6	1	4226-63	N/F	Front
8310-137-R	63/1	0.8-3.0	4.7	1.6	1	4226-63	N/F	Rear
8310-137-2-F	63/1	0.8-3.0	4.7	1.6	2	4226-63	N/F	Front
8310-137-2-R	63/1	0.8-3.0	4.7	1.6	2	4226-63	N/F	Rear
8310-138-F	103/1	0.8-3.0	6.0	1.6	1	4228-103	N/F	Front
8310-138-R	103/1	0.8-3.0	6.0	1.6	1	4228-103	N/F	Rear
8310-138-2-F	103/1	0.8-3.0	6.0	1.6	2	4228-103	N/F	Front
8310-138-2-R	103/1	0.8-3.0	6.0	1.6	2	4228-103	N/F	Rear
8310-138-3-T	103/1	0.8-3.0	6.0	1.6	3	4228-103	N/F	Front/Rear
8310-138-4-T	103/1	0.8-3.0	6.0	1.6	4	4228-103	N/F	Front/Rear

* Refer to Individual data sheet for detailed specifications on internal programmables.

** Add Suffix S to end of Model number for SMA connectors. Add N to the end of the Model number for ethernet option, IEEE-488 bus not included.

Ordering Guide...8310 Series with 3200 Programmables

Model No	Attenuation Value (dB)	Frequency Range (GHz)	Insertion Loss (maximum)	SWR (Maximum)	No of Channels	Attenuator Model No.*	Connector Type **	Conn Location
8310-35-F-E	127/1	dc-3.0	6.0 dB	1.4	1	3200T-1E	N/F	Front
8310-35-R-E	127/1	dc-3.0	6.0 dB	1.4	1	3200T-1E	N/F	Rear
8310-35-2-F-E	127/1	dc-3.0	6.0 dB	1.4	2	3200T-1E	N/F	Front
8310-35-2-R-E	127/1	dc-3.0	6.0 dB	1.4	2	3200T-1E	N/F	Rear
8310-35-3-T-E	127/1	dc-3.0	6.0 dB	1.4	3	3200T-1E	N/F	Front to Rear
8310-35-4-T-E	127/1	dc-3.0	6.0 dB	1.4	4	3200T-1E	N/F	Front to Rear
8310-36-F-E	64.5/0.1	dc-3.0	8.0 dB	1.4	1	3209T-1E	N/F	Front
8310-36-R-E	64.5/0.1	dc-3.0	8.0 dB	1.4	1	3209T-1E	N/F	Rear
8310-36-2-F-E	64.5/0.1	dc-3.0	8.0 dB	1.4	2	3209T-1E	N/F	Front
8310-36-2-R-E	64.5/0.1	dc-3.0	8.0 dB	1.4	2	3209T-1E	N/F	Rear
8310-36-3-T-E	64.5/0.1	dc-3.0	8.0 dB	1.4	3	3209T-1E	N/F	Front to Rear
8310-37-F-E	63.75/0.25	dc-3.0	6.0 dB	1.4	1	3200T-2E	N/F	Front
8310-37-R-E	63.75/0.25	dc-3.0	6.0 dB	1.4	1	3200T-2E	N/F	Rear
8310-37-2-F-E	63.75/0.25	dc-3.0	6.0 dB	1.4	2	3200T-2E	N/F	Front
8310-37-2-R-E	63.75/0.25	dc-3.0	6.0 dB	1.4	2	3200T-2E	N/F	Rear
8310-37-3-T-E	63.75/0.25	dc-3.0	6.0 dB	1.4	3	3200T-2E	N/F	Front to Rear
8310-37-4-T-E	63.75/0.25	dc-3.0	6.0 dB	1.4	4	3200T-2E	N/F	Front to Rear
8310-38-F-E	63/1	dc-3.0	5.25 dB	1.4	1	3206T-1E	N/F	Front
8310-38-R-E	63/1	dc-3.0	5.25 dB	1.4	1	3206T-1E	N/F	Rear
8310-38-2-F-E	63/1	dc-3.0	5.25 dB	1.4	2	3206T-1E	N/F	Front
8310-38-2-R-E	63/1	dc-3.0	5.25 dB	1.4	2	3206T-1E	N/F	Rear
8310-38-3-T-E	63/1	dc-3.0	5.25 dB	1.4	3	3206T-1E	N/F	Front to Rear
8310-38-4-T-E	63/1	dc-3.0	5.25 dB	1.4	4	3206T-1E	N/F	Front to Rear
8310-352-F	103/1	dc-6.0	6.00 dB	1.55	1	3408T-103	N/F	Front
8310-352-R	103/1	dc-6.0	6.00 dB	1.55	1	3408T-103	N/F	Rear
8310-352-2-F	103/1	dc-6.0	6.00 dB	1.55	2	3408T-103	N/F	Front
8310-352-2-R	103/1	dc-6.0	6.00 dB	1.55	2	3408T-103	N/F	Rear
8310-352-3-T	103/1	dc-6.0	6.00 dB	1.55	3	3408T-103	N/F	Front to Rear
8310-352-4-T	103/1	dc-6.0	6.00 dB	1.55	4	3408T-103	N/F	Front to Rear

Ordering Guide...8310 Series with 150 Programmables

Model No	Attenuation Value (dB)	Frequency Range (GHz)	Insertion Loss (maximum)	SWR (Maximum)	No of Channels	Attenuator Model No.*	Connector Type **	Conn Location
8310-201-F	70/10	dc-18.0	3.25 dB	1.75	1	150T-70	SMA/F	Front
8310-201-R	70/10	dc-18.0	3.25 dB	1.75	1	150T-70	SMA/F	Rear
8310-201-2-F	70/10	dc-18.0	3.25 dB	1.75	2	150T-70	SMA/F	Front
8310-201-2-R	70/10	dc-18.0	3.25 dB	1.75	2	150T-70	SMA/F	Rear
8310-202-F	121/1	dc-18.0	5.25 dB	1.95	1	150T-11+150T-110	SMA/F	Front
8310-202-R	121/1	dc-18.0	5.25 dB	1.95	1	150T-11+150T-110	SMA/F	Rear
8310-204-F	62/2	dc-18.0	3.70 dB	1.95	1	150T-62	SMA/F	Front
8310-204-R	62/2	dc-18.0	3.70 dB	1.95	1	150T-62	SMA/F	Rear
8310-204-2-F	62/2	dc-18.0	3.70 dB	1.95	2	150T-62	SMA/F	Front
8310-204-2-R	62/2	dc-18.0	3.70 dB	1.95	2	150T-62	SMA/F	Rear

* Refer to Individual data sheet for detailed specifications on internal programmables.

** Add Suffix S to end of Model number for SMA connectors. Add N to the end of the Model number for ethernet option, IEEE-488 bus not included.

Programmable Attenuators



Ordering Guide...8311 Series!

Model No	Attenuation Value (dB)	Frequency Range (GHz)	Insertion Loss (maximum)	SWR (Maximum)	No of Channels	Attenuator Model No.*	Connector Type	Conn Location
8311-38-6-F-E	63/1	dc-2.0	5.25 dB	1.40	6	3206T-1E	N/F	Front
8311-38-12-T-E	63/1	dc-2.0	5.25 dB	1.40	12	3206T-1E	N/F	Front-Rear
8311-137-6-F	63/1	0.8-3.0	4.70 dB	1.60	6	4226-63	N/F	Front
8311-202-2-F	121/1	dc-18.0	5.25 dB	1.95	2	150T-11+150T-110	SMA/F	Front
8311-202-3-F	121/1	dc-18.0	5.25 dB	1.95	3	150T-11+150T-110	SMA/F	Front
8311-204-6-F	62/2	dc-18.0	3.70 dB	1.95	6	150T-62	SMA/F	Front
8311-352-6-F	103/1	dc-6.0	6.00 dB	1.55	6	3408T-103	SMA/F	Front
8311-352-9-T	103/1	dc-6.0	6.00 dB	1.55	9	3408T-103	SMA/F	Front-Rear

Physical Dimensions

8310 Series:

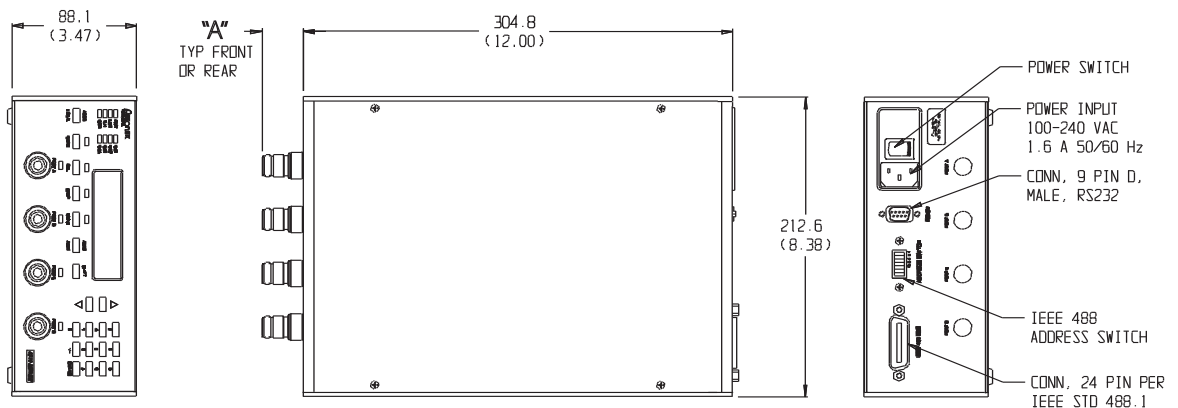

8311 Series:

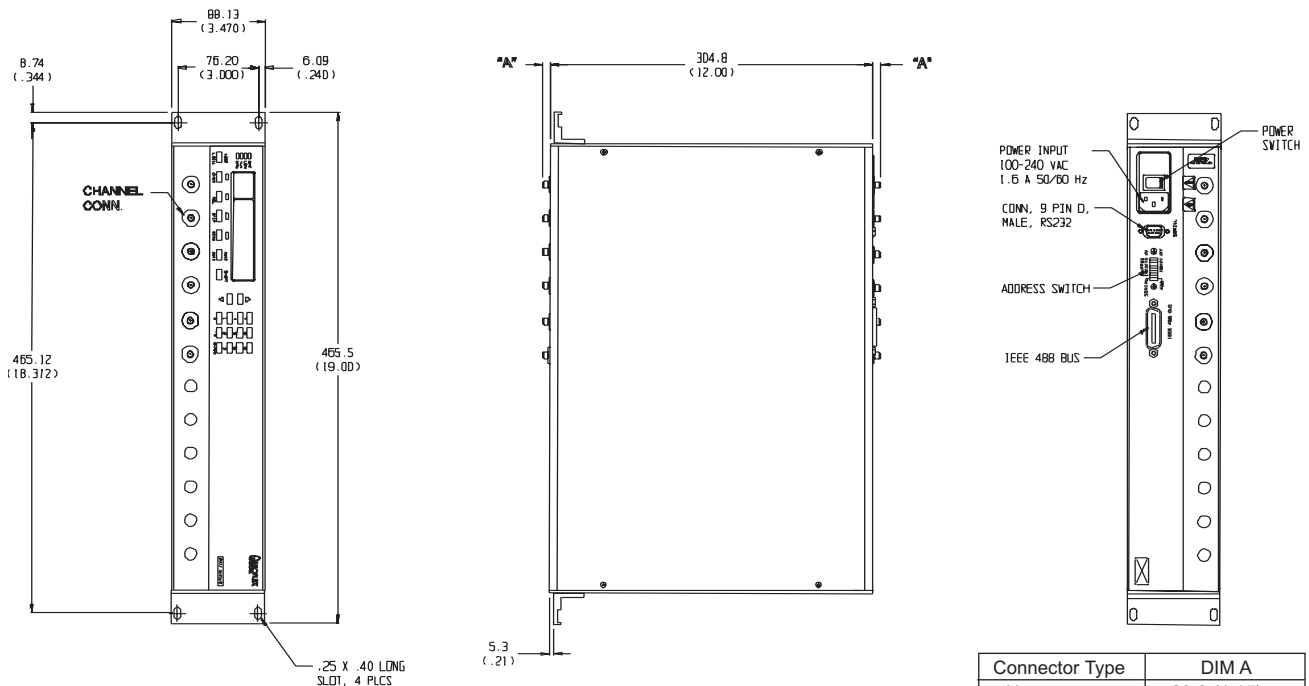

NOTE:

1. All dimensions are given in mm (inches) and are maximum, unless otherwise specified.
2. Connector location (Front/Rear) may vary depending on Model ordered.